

* = Conical form tapering downward.
 Untoleranced dimensions per GTA 13/5 DIN 1688

LID

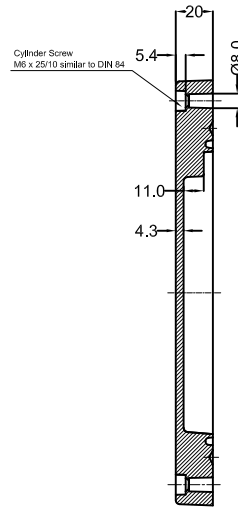
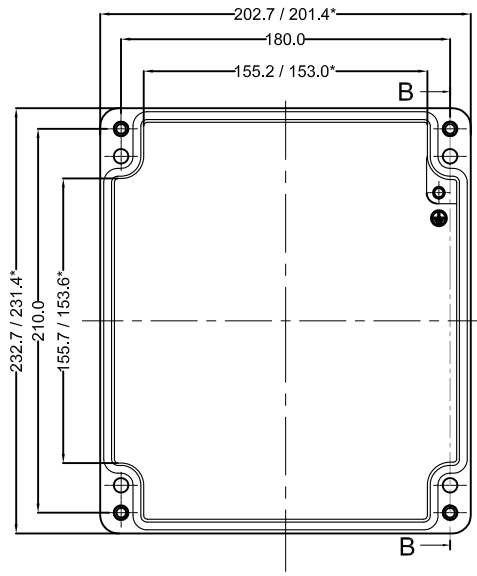

SECTION B-B

BASE

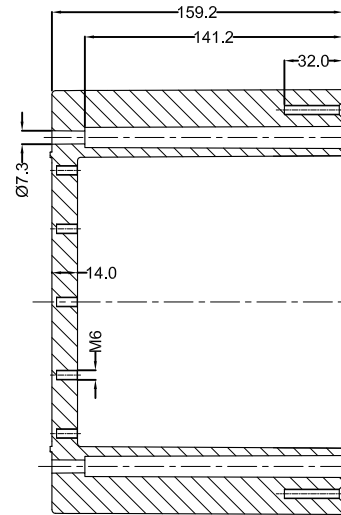
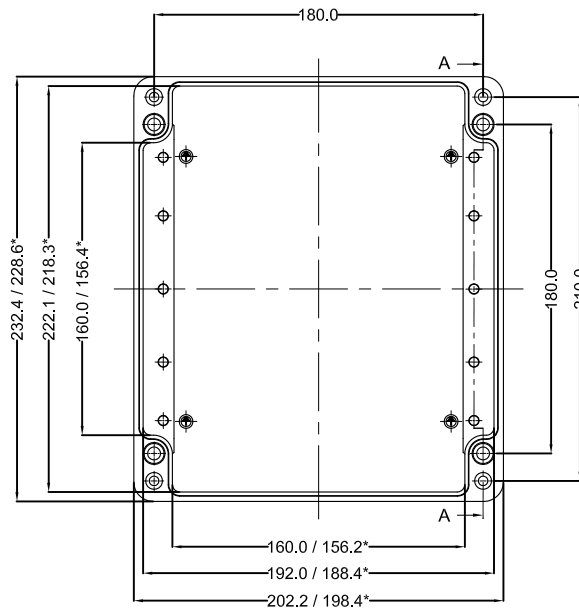

SECTION A-A

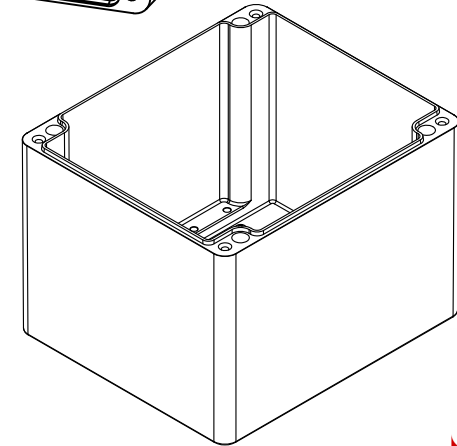
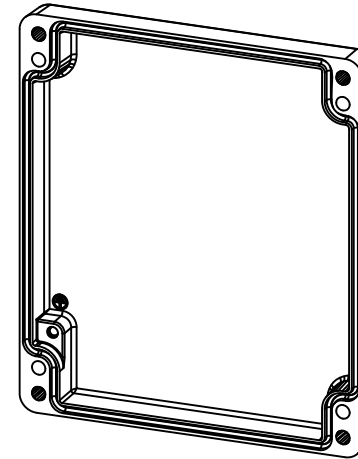

OPTIONAL ACCESSORIES		
PART NAME	QTY.	AVAILABILITY
MOUNTING PLATE	1	Y
EXTERNAL HINGE	2	Y
INTERNAL HINGE	2	Y
MOUNTING BRACKETS	4	Y
NEOPRENE/SILICON GASKET	1	Y
DIN RAIL TS15	-	N
DIN RAIL TS35	1	Y



QUANTITY 1	MATERIAL :- ALe112 (Din230)	MACH.NAME -	DATE 18/06/18	SIGN	NAME RRPL	DESIGN
TOLERANCE		WEIGHT :- -	TITLE :- JUNCTION BOX 230 x 200 x 180		18/06/18	MANOJ DRAWN
±0.2	ROUGHNESS	FINISH :- NATURAL	18/06/18		PAVAN	CHECKED
±0.2	HOLES	ALL DIMENSION ARE IN MM	18/06/18		S. D.	APPROVED
±1.0°	ANGLES	RJ 30	SCALE			