

Datasheet

ENGLISH

RS PRO, 12 V dc, 778 gcm, Brushed DC Geared Motor, Output Speed 2417 rpm

Stock No: 420-675

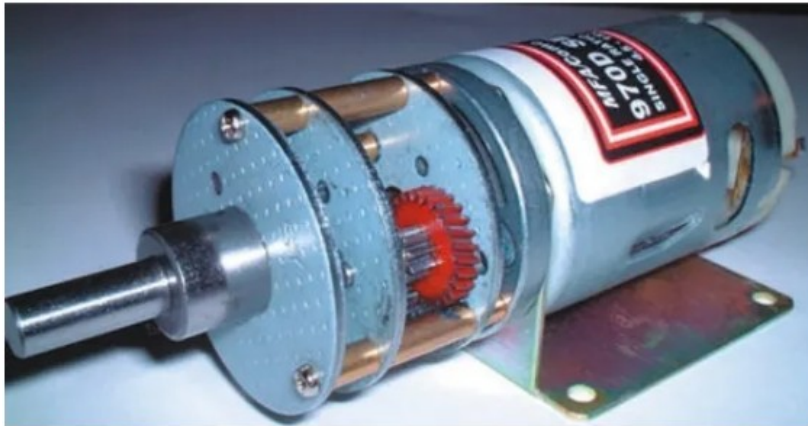

Specifications:

Output Speed	2417 rpm
Supply Voltage	4.5 - 15 V dc
Maximum Output Torque	778 g.cm
DC Motor Type	Brushed
Shaft Diameter	6mm
Power Rating	19.8 W
Gearhead Type	Spur
Length	77mm
Width	39.3mm
Current Rating	2.81 A
Weight	274g

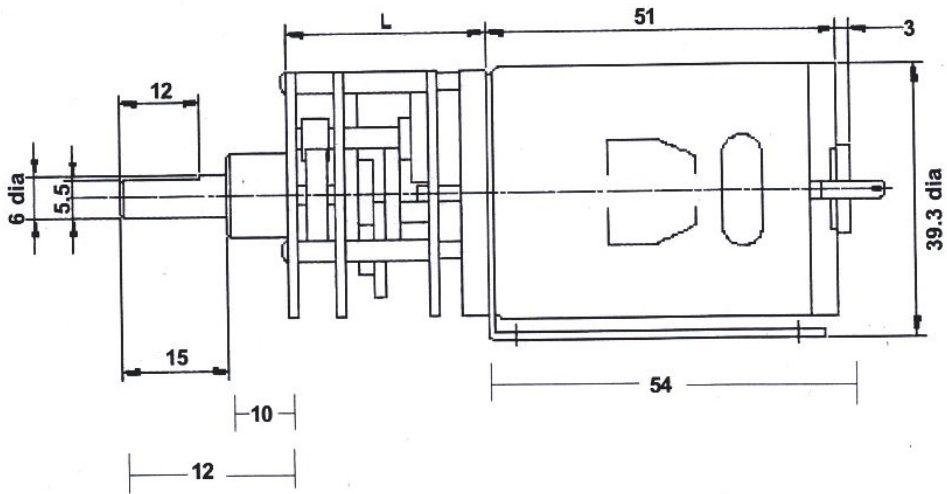

Operating relative humidity 20% ~ 85%
 Operating temperature range -10°C ~ +60°C

Ratio	L
6:1	26.0mm

Gearbox Housing material	Metal
Backlash at no-load	< 2°
Bearing at output	Sleeve bearings
Radial load (10mm from flange)	< 1 kgf
Shaft axial load	< 0.7 kgf
Shaft press fit force max	< 5 kgf
Radial play of shaft	< 0.05mm
Thrust play of shaft	< 0.35mm

Reduction Ratio	Rated tolerance Torque	Max momentary Tolerance Torque	Efficiency
1/6	1.0 kgf-cm Max.	3.0 kgf-cm	81%

Reduction Table RPM SUPPLY VOLTAGE	4.5v	6v	9v	12v	15v
420-675	906	1209	1813	2417	3021

Note: Motor speeds may vary by (+) or (-) 12.5%

