

Datasheet

s.81 side drain

full port ½"-2" hot forged brass ball valves

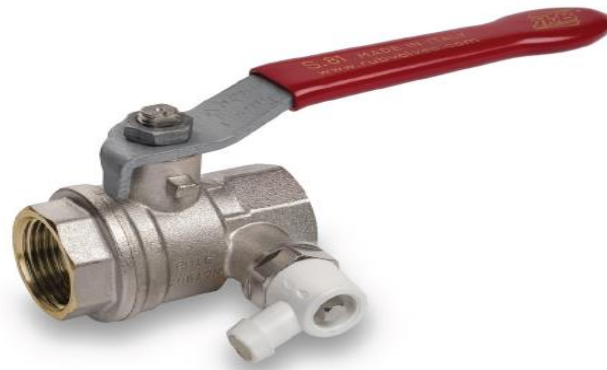

Quality:

- Dual sealing system allows valve to be operated in either direction making installation easier
- No metal-to-metal moving parts
- No maintenance ever required
- Handle clearly shows ball position
- Silicone-free lubricant on all seals
- Chrome plated brass ball for longer life
- Travel stops on body to avoid stresses at stem

Body:

- Hot forged sand blasted, external nickel plated brass body and cap sealed with Loctite® or equivalent thread sealant
- Finest brass according to EN 12165 and EN 12164 (formerly DIN 17660 and UNI 5705-65) specifications
- Double side drain allows easy and safe downstream line venting

Stem:

- Blowout-proof nickel plated brass stem
- Two FPM O-rings at the stem for maximum safety

Seals:

- Pure PTFE self-lubricating seats with flexible-lip design



Threads:

- ISO 228 parallel female by female threads
- G 1/4" ISO 228 drain on both side

Flow:

- Full port to DIN 3357 for maximum flow

Handle:

- Geomet® carbon steel handle with thick PVC dip coating. Handle coating offers both thermal and electrical protection
- Handle removable with valve in service

Working Pressure:

- 16 Bar (230 PSI)
- non-shock cold working pressure
- Pressure applicable to valve, not to side tap

Working Temperature:

- -20°C (-4°F) / +170°C (+350°F)
- Temperature applicable to valve, not to side tap

Options:

- Stem extension
- T-handle
- Oval lockable handle
- AISI 430 stainless steel handle
- Patented locking device
- Compact drain

Upon Request:

- AISI 316 stainless steel ball
- Glass filled PTFE seals
- Custom Design
- Male by Female threads

Approved by or in compliance with:

- GOST-R (Russia)
- Hygiene and epidemic center in Moscow city (Russia)
- RoHS Compliant
- EAC - Declaration of conformity (Russia-Kazakhstan-Belarus)

NOTE: Approvals apply to specific configurations/sizes only.

Part Description	Q.ty	Material
1 Nickel plated body (external treatment)	1	CW617N
2 Seat	2	PTFE
3 Chrome plated ball	1	CW617N
4 Nickel plated end cap (external treatment)	1	CW617N
5 Nickel plated stem O-ring design	1	CW617N
6 Geomet® nut	1	CB4FF
7 O-Ring	2	FPM
8 Red PVC coated Geomet® steel handle	1	DD11
9 Nickel plated cap	1	CW617N
10 O-Ring	2	EPDM
11 Side tap	1	-

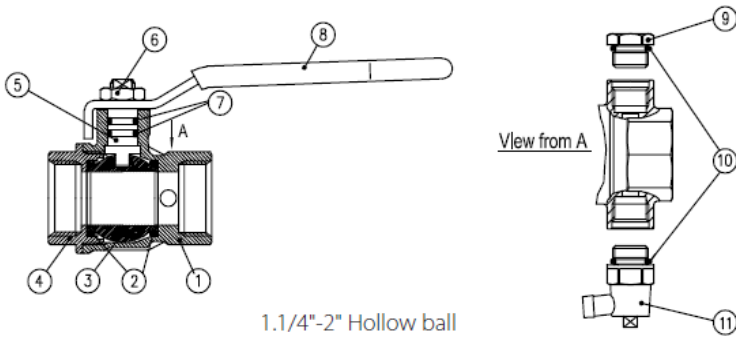

1.1/4"-2" Hollow ball

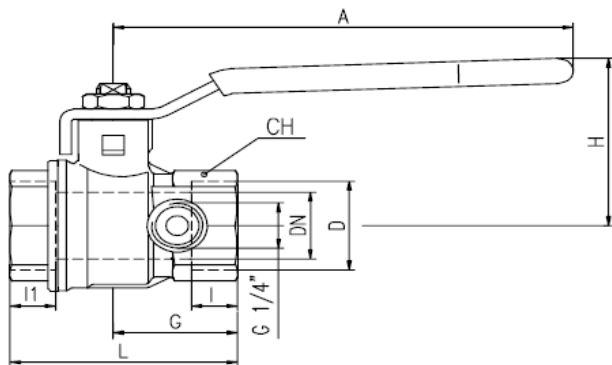

Code	S81D00	S81E00	S81F00	S81G00	S81H00	S81I00
D (Inch)	1/2	3/4	1	1.1/4	1.1/2	2
DN (mm)	15	20	25	32	40	50
I1 (mm)	11	12	21	23	17	26.5
I (mm)	11	12	14	15	17	19
L (mm)	56	59.5	79.5	90.5	95.5	118.5
G (mm)	31	32.5	39	44	50.5	58
A (mm)	100	120	120	158	158	158
H (mm)	43	50	54	73	79	86
CH (mm)	25	31	40	49	54	68.5

Pressure-Temperature Chart

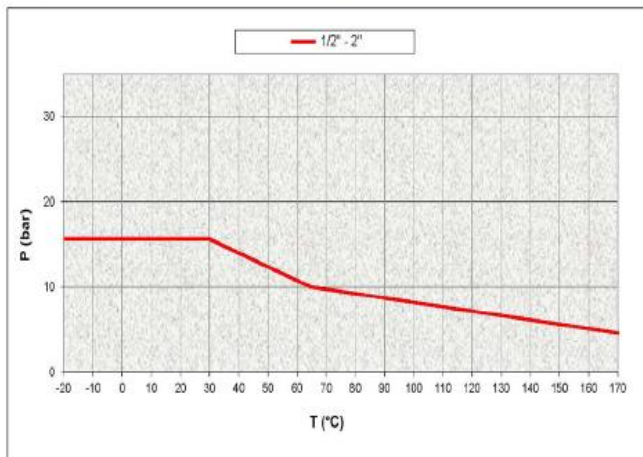

Pressure Drop Chart

