



EQi – V2 M Series Pumps Intelligent Brushless Controller

RS MICROPUMPS: 1253571.

*Suitable for use with all versions of the M500 and M510 Micropump
(Patents Pending, Quality Assured ISO 9001, RoHS compliant)*

INTRODUCTION

The TCS EQi V2 control board is a highly efficient, small and lightweight device and can be quickly and easily installed into the smallest spaces, in a vast range of laboratory, prototype and production equipment.

The EQi V2 will accept an input voltage of up to 30v DC. The output from the EQi V2 can be controlled by either the on board speed control pot or from an external 0-5v input. The flow direction can be reversed. The board can be switched on and off by an Enable function. Pump RPM can be measured by a pulse output pin.

The speed of the pump is 'Governed' above 12v to maintain a constant flow as the back pressure increases. This provides a flatter pressure/flow curve. Below 12v the pump speed will decrease as the voltage is lowered.

ELECTRICAL CONNECTION

Voltage: up to 30 DC
Input: 2 screw terminal : UP to 30v/GND
Output: 3 screw terminal : Phase XYZ

1. Connect the 3 wires of the Micropump to the 3 screw terminals marked 'Phase XYZ'.
2. Connect the Input power to the 2 screw terminals marked 'Up to 30V (+) & GND (-)'.
3. Set Jumper plug for either onboard speed control in accordance with the wiring diagram or remove it entirely if using 0-5V control. NOTE: if using the external 0-5v control or if using the enable or direction features please use the supplied leads to connect to the relevant pins as labelled in the wiring diagram.
4. If using the EQi-V2 in 0-5V control remove the jumper pin from the 6 pin header. Connect the '0-5V Input pin' to the positive of your external adjustable power supply, connect the 'GND' pin to ground of the same power supply. 0V the pump will be switched off, as voltage is increased the pump speed will increase, at 5V the pump will be at full speed. NOTE: Do not exceed 5V on the '0-5V Input pin' this will cause irreversible damage to the EQi V2.
5. To reverse the motor direction, connect the 'Direction pin' to 'GND'. Please note that M series pumps are not reversible, although the motor will reverse the flow direction will remain the same.
6. If you require to use the enable function (ON/OFF Switch) connect the 'Enable pin' to 'GND' this will turn the pump off. When the pin is disconnected the pump will be on.

TCS suggest that you begin testing with a supply voltage of 12v.



EQi – V2 M Series Pumps Intelligent Brushless Controller

It is advised to use an 'always live' supply voltage as the EQi V2 is instant start. If a slow starting power supply is used it may cause the EQi V2 not to start. If this is the case then turn on PSU first and then connect the EQi.

Wiring Diagram

Always make all connections before powering the EQi V2.

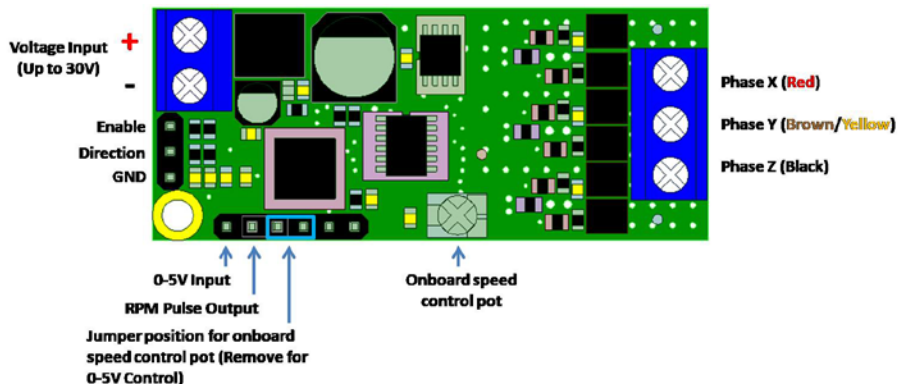

RPM Pulse Output (Reading pump RPM)

The pin marked as 'RPM Pulse Output' provides a frequency output (Hz) this can be measured with an oscilloscope. Some multimeters also have the ability to read frequency. Connect the 'RPM Pulse Output pin' to an oscilloscope probe and the ground from the probe to the ground on the three pin header, this will display as a square waveform in which frequency can be read.

For the correct RPM the read frequency must be multiplied by 10.

Example $1000\text{Hz} \times 10 = 10000\text{ RPM}$.

The M500 and M510 series will be at approximately 9000 RPM at full free flow.

Maximum Operating Pressure

M500- 1.5 Bar (21.75psi)

CAUTION

Do not exceed the maximum operating pressure for your pump
Do not exceed the maximum operating current draw of **2 amps**.
Exceeding these limits may cause damage to the Micropump.