



ENGLISH

Datasheet

RS Pro Round Bar Centre Finder

RS Stock No: 264-3514



Specifications:

U.S. Federal Specification: GGG-G-17C/16 Jun 1987

Accurately and quickly locates centre on round work pieces.

3/8" shank located in drill chuck or collet.

Centre obtained when pointer lines up with line on shaft.

Satin Chrome Finish.

Minimum Shaft Diameter: 8mm

Maximum Shaft Diameter: 80mm

Order Code	Manufacturers Code	Description
264-3514	4200-100	Round Bar Centre Finder



ENGLISH

Datasheet RS Pro Round Bar Centre Finder

RS Stock No: 264-3514

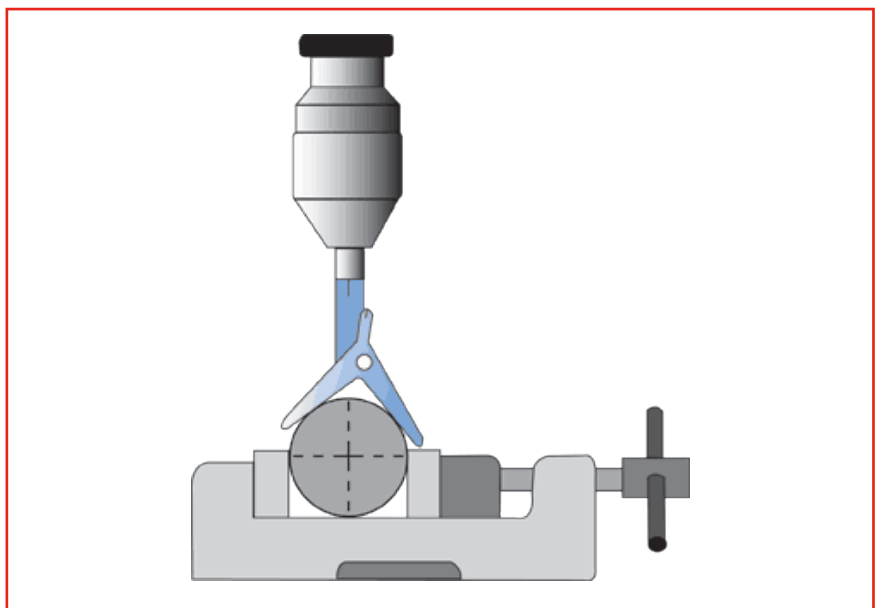

Instructions:

Place Centre Finder in drill chuck or collet located in machine spindle

Align legs of Centre Finder perpendicular to work piece

Move machine spindle down until legs contact work piece

View pointer and line scribed on shaft of Centre Finder

If they are not in line, move machine X or Y axis until correct line up is achieved

Order Code	Manufacturers Code	Description
264-3514	4200-100	Round Bar Centre Finder