

FEATURES

- Cage Nuts, carbon steel
- Ideal for fixing front panels onto various systems
- Ideal for fixing front panels onto electrical equipment

Steel RS PRO M8 Cage Nut

RS Stock No.: 806-7758



RS Professionally Approved Products bring to you professional quality parts across all product categories. Our product range has been tested by engineers and provides a comparable quality to the leading brands without paying a premium price.

Product Description

These caged nuts from RS consist of a range of zinc plated cage nuts, also known as a captive nut, available in M8 and M10 thread sizes.

General Specifications

Thread Size	M8
Material	Steel
Finish	Zinc Plated

Mechanical Specifications

Overall Width	16.58mm
Cut-Out Dimensions	12.8mm x 12.8mm
Cut-Out Length	12.8mm
Cut-Out Width	12.8mm
For Panel Thickness Maximum	3.2mm
For Panel Thickness Minimum	1.83mm



RS Part No	Thread Size	Panel Range Inch	A mm	B mm	C mm	T mm	H mm	Standard Finish
8067742	M8	1.00/1.70	16.00	16.50	7.90	0.50	12.30	K,L and Y
8067745	M8	0.71/1.63	16.37	16.58	6.63	0.38	12.80	K,L and Y
8067749	M8	1.70/2.30	16.00	16.50	7.90	0.50	12.30	K,L and Y
8067758	M8	1.83/3.20	16.37	16.58	6.63	0.38	12.80	K,L and Y
8067751	M8	3.30/4.50	16.37	16.58	6.63	0.38	12.80	K,L and Y
8067755	M10	1.00/1.70	16.00	16.50	7.90	0.50	12.30	K,L and Y
8067764	M10	0.71/1.63	16.37	16.58	6.63	0.38	12.80	K,L and Y
8067767	M10	1.70/2.30	16.00	16.50	7.90	0.50	12.30	K,L and Y
8067761	M10	1.83/3.20	16.37	16.58	6.63	0.38	12.80	K,L and Y
8067770	M10	3.30/4.50	16.37	16.58	6.63	0.38	12.80	K,L and Y

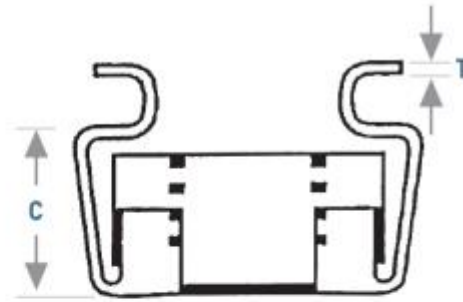
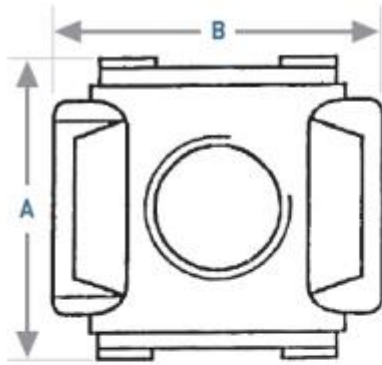

Dimension of aperture

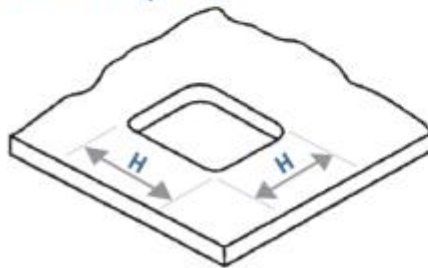

Application

