

SPECIFICATION

FOR

EUROPEAN POWER SUPPLY CORDSET (PB FR)

CORD : H03VVH2-F 2X0.75mm² PVC LEAD FREE

CUSTOMER : VPE/RS COMPONENTS

CUSTOMER'S PART No. : 1469114(V-NOVUS EURO 2 PIN-C7 1.8M)

VOLEX'S SPEC. REF No. : 172907/13

ISSUE No. : 006

DATE : 26TH NOVEMBER 2019

CUSTOMER APPROVED :

APPROVED BY	:	
SIGNATURE	:	
APPROVED DATE	:	
No. OF PAGES	:	

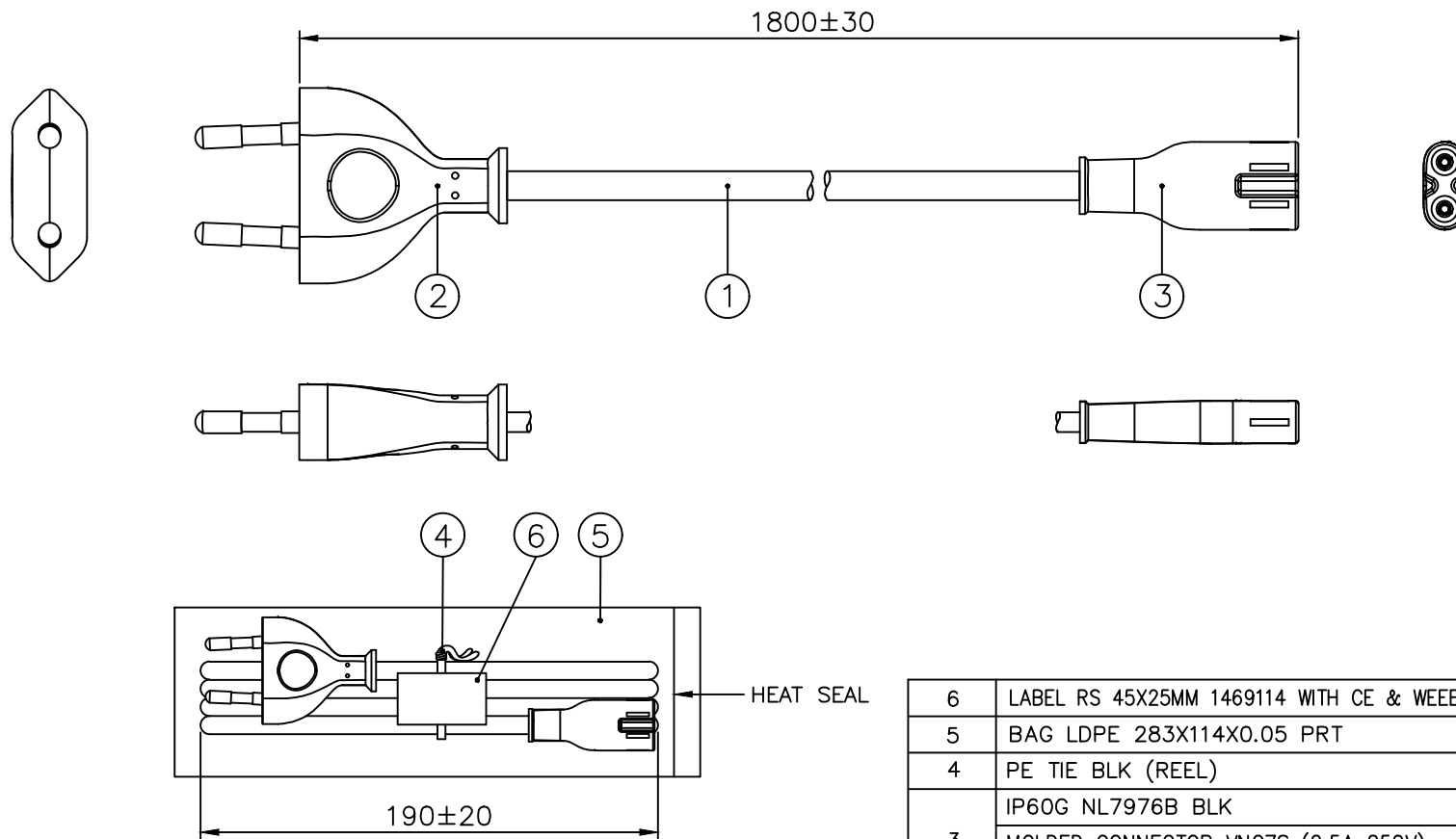

APPROVED SOURCE FOR CABLE

1. BAO HING(SHENZHEN).

NOTE :

1. ALL DIMENSIONS IN mm.
2. THE CORD SHALL COMPLY WITH EN 50525-2-11.
3. THE MOLDED PLUG SHALL COMPLY WITH SPECIFICATION EN 50075.
4. THE MOLDED CONNECTOR SHALL COMPLY WITH IEC 60320-1 OR EN 60320-1.
5. THIS PART CAN BE MANUFACTURED AT ANY LOCATION WHICH HAS SAFETY APPROVAL.

6	LABEL RS 45X25MM 1469114 WITH CE & WEEE	6103454	1
5	BAG LDPE 283X114X0.05 PRT	904028	1
4	PE TIE BLK (REEL)	6310101	1X152MM
3	IP60G NL7976B BLK	4100115	-
	MOLDED CONNECTOR VNC7S (2.5A 250V)	VNC7S-V	1
2	IP60G NL7976B BLK	4100115	-
	MOLDED PLUG VNEU2.5S2 (2.5A 250V)	VNEU2.5S2-V	1
1	H03VVH2-F 2X0.75 BLK LF (INDENT)	1211372	1

S/N	DESCRIPTION	ITEM NUMBER	QTY
TITLE : EUROPEAN POWER SUPPLY CORDSET (PB FR)		SCALE : N.T.S.	
CUSTOMER : VPE/RS COMPONENTS		PAGE : 1/1	
CUSTOMER PART NUMBER : 1469114(V-NOVUS EURO 2 PIN-C7 1.8M)		ISSUE	
Reference Number : 172907/13 (VPE11-147-19)		006	
SALES :	QA :	ENGRG : <i>ROB-LW</i>	CHECKED BY : <i>Peiyuan</i>
Date :	Date :	Date : 26/11/19	DATE : 26/11/19
			DRAWN BY : <i>PEIYUAN</i>
			Date : 26/11/19

DRAWING NUMBER : REVISION :

L-0654

B

R2.0(4X)

45.0

14,6 REF

25.0

5 MIN.

CUSTOMER P/N
SEE TABLE

XXXXXXXXX

1

RoHS

RED BACKGROUND(PANTONE 172 C)
WITH WHITE PRINT, SEE PICTURE BELOW

WHITE BACKGROUND WITH BLACK PRINT

Made in China



5

SPECIFICATION :

PRODUCT NO	AW32C9 WITH PP COATING
FACESTOCK MATERIAL	ART PAPER
FACESTOCK THICKNESS	72 μ M \pm 10%
FACESTOCK COLOUR	WHITE
FACESTOCK SURFACE FINISH	GLOSSY
ADHESIVE BASE	ACRYLIC EMULSION
SHELF LIFE	1 YEAR

BARCODE: CODE 128A, SCAN SHOW CUSTOMER P/N



PICTURE FOR COLOUR PRINT

NOTES :

1. ALL DIMENSION IN MM.
2. GENERAL TOLERANCE \pm 1MM, UNLESS OTHERWISE SPECIFIED.
3. \diamond CRITICAL DIMENSIONS, WHERE Y IS IN NUMERICAL DIGITS.
4. WHITE BACKGROUND WITH BLACK PRINT.
5. FONT: ARIAL, BOLD.

DRAWN :	ALICE	REV	IMM/ECR	BY	DATE	REV	IMM/ECR	BY	DATE	TITLE :	RS LABEL 45X25MM WITH CE & WEEE LOGO			
RELEASED :	22/01/19	A	190190	ALICE	04/04/19					ITEM NO.:	FILENAME :	SCALE :	PROJ. :	PAGE :
	SIGN	DATE	B	190589	ALICE	11/11/19				SEE TABLE	.\LABEL\PREPRINTED\L-0654	2 : 1		1/2
CHECKED :	<i>Alice</i>	<i>11/11/19</i>												
APPROVED :	<i>[Signature]</i>	<i>11/11/19</i>												

DRAWING NUMBER : REVISION :

L-0654

B

TABLE \triangle B

CUSTOMER P/N	ITEM NO.	CUSTOMER P/N	ITEM NO.	CUSTOMER P/N	ITEM NO.	CUSTOMER P/N	ITEM NO.
1247409	6103431-XXXX	321203	6103475-XXXX	7440929	6103502-XXXX	262 1154 0001	6103536-XXXX
1468803	6103441-XXXX	321219	6103476-XXXX	7440931	6103503-XXXX	262 1160 0001	6103537-XXXX
1468804	6103442-XXXX	426424	6103478-XXXX	7440935	6103504-XXXX	262 1176 0001	6103538-XXXX
1469102	6103443-XXXX	531100	6103479-XXXX	7440941	6103505-XXXX	262 1182 0001	6103539-XXXX
1469103	6103444-XXXX	531116	6103480-XXXX	8188903	6103507-XXXX	680 3798 0001	6103540-XXXX
1469104	6103445-XXXX	6151154	6103481-XXXX	8188909	6103508-XXXX	426 373 0001	6103541-XXXX
1469105	6103446-XXXX	6151176	6103482-XXXX	8188912	6103509-XXXX	426 389 0001	6103542-XXXX
1469106	6103447-XXXX	6151182	6103483-XXXX	8188915	6103510-XXXX	426 395 0001	6103543-XXXX
1469107	6103448-XXXX	6266593	6103484-XXXX	8188919	6103511-XXXX	426 402 0001	6103544-XXXX
1469108	6103449-XXXX	6266600	6103485-XXXX	9010753	6103512-XXXX	426 418 0001	6103545-XXXX
1469109	6103450-XXXX	6266616	6103486-XXXX	9092156	6103513-XXXX	452 669 0001	6103546-XXXX
1469110	6103451-XXXX	6266688	6103489-XXXX	9092168	6103516-XXXX	487 277 0001	6103547-XXXX
1469111	6103452-XXXX	6266694	6103490-XXXX	9092171	6103517-XXXX	487 277 0010	6103548-XXXX
1469112	6103453-XXXX	6266701	6103491-XXXX	9092174	6103518-XXXX	489 201 0001	6103549-XXXX
1469114	6103454-XXXX	6266717	6103492-XXXX	9092178	6103519-XXXX	489 217 0001	6103550-XXXX
1469115	6103455-XXXX	6266723	6103493-XXXX	9092184	6103521-XXXX	489 346 0001	6103551-XXXX
1469116	6103456-XXXX	6266745	6103494-XXXX	9092193	6103524-XXXX	489 352 0001	6103552-XXXX
1469117	6103457-XXXX	7316157	6103495-XXXX	445 740	6103528-XXXX	490 217 0001	6103553-XXXX
1469118	6103458-XXXX	7316166	6103497-XXXX	449 297	6103529-XXXX	490 223 0001	6103554-XXXX
1469119	6103459-XXXX	7316175	6103498-XXXX	449 326	6103530-XXXX	490 239 0001	6103555-XXXX
1469120	6103460-XXXX	7316201	6103499-XXXX	815 846	6103531-XXXX	490 245 0001	6103556-XXXX
321180	6103473-XXXX	7316208	6103500-XXXX	268 2610	6103532-XXXX	311-9321-0000	6103557-XXXX
321196	6103474-XXXX	7440925	6103501-XXXX	311 9315	6103533-XXXX	311-9337-0000	6103558-XXXX
				262 1126 0001	6103535-XXXX	311-9359-0000	6103559-XXXX

DRAWN : ALICE	REV	IMM/ECR	BY	DATE	REV	IMM/ECR	BY	DATE	TITLE :	RS LABEL 45X25MM WITH CE & WEEE LOGO				
RELEASED : 22/01/19	A	190190	ALICE	04/04/19					ITEM NO.:	FILENAME :	SCALE :	PROJ. :	PAGE :	
	SIGN	DATE	B	190589	ALICE	11/11/19			SEE TABLE	.\LABEL\PREPRINTED\L-0654	2 : 1		2/2	
CHECKED : <i>[Signature]</i>														
APPROVED : <i>[Signature]</i>														

REV.	DESCRIPTION	DATE
E	AMEND WORDS FM. 'NORMAL' TO 'NOMINAL'.	14/10/05
F	CHANGE THE COMPLIANCE STANDARD PER SAFETY.	20/12/13
	UPDATE FORMAT AS SHOWN.	

1. PVC FLEXIBLE CORD

1.1 SCOPE



This specification shall be in accordance with EN 50525-2-11. Δ

1.2 CONSTRUCTION

CONDUCTOR	ANNEALED COPPER WIRE
INSULATION	PVC (BLUE AND BROWN)
JACKET	PVC

ITEM	UNIT	SPEC. VALUE		
TEMPERATURE RATING	°C	70		
RATED VOLTAGE	V	300/300		
NO. OF CORE	NO.	2		
CONDUCTOR NOMINAL AREA	mm ²	0.75		
MIN. AVE. THICKNESS OF INSULATION	mm	0.50		
MIN. THICKNESS AT ANY POINT OF INSULATION	mm	0.35		
MIN. AVE. THICKNESS OF JACKET	mm	0.60		
MIN. THICKNESS AT ANY POINT OF JACKET	mm	0.41		
OVERALL DIAMETER OF JACKET	mm	3.2X5.2~3.8X6.3		
VOLTAGE TEST (D.C)	-	2000 Va.c. for 5 mins (minimum) or 5000 Vd.c. for 5 mins(minimum)		
DIELECTRIC- STRENGTH TEST	IMMERSED IN WATER, 20±5°C FOR MINIMUM 1HOUR	ON COMPLETED CABLE	-	2000V for 15 mins(minimum)
		ON CORES	-	1500V for 5 mins(minimum)
INSULATION RESISTANCE TEST (70°C)	MΩ./Km	> 0.01		
CONDUCTOR RESISTANCE TEST (20°C)	Ω/Km	< 26		

TITLE : CABLE SPECIFICATION
EUROPEAN APPROVED POWER SUPPLY CABLE
H03VVH2-F 2X0.75mm²

SPEC NO. :	APPROVED BY :	CHECKED BY :	DRAWN BY :	REVISION :
CS-013EU			HONGYAN	F
	DATE :	DATE :	DATE :	PAGE :
	23/12/13	20/12/13	20/12/13	1/1

CABLE MARKING

REV.	DESCRIPTION	DATE
A	INITIAL RELEASE	11/10/02
B	UPDATE THE FORMAT AS SHOWN.	12/01/05
	ADD IN '(EU/SAA/SAB/IEC)' ON THE TITLE.	

BAO HING (SHENZHEN)

: - H03VVH2-F 2X0.75mm² <VDE> KEMA-KEUR + S + S + S
 <öVE> CEPEC IEMMEQU SABS 1574 (S) (N) (D) (F) BAOHING
 LTSA-2F N14586 CE LF

DRAWN	<i>Cai ZX</i>	12/01/05	FILENAME :	TITLE : CABLE MARKING (EU/SAA/SAB/IEC) 
CHECK	<i>Weta</i>	13/01/05	CABLE MARKING/	
APPR	<i>Weta</i>	13/11/05	BAO HING/H03/	
SCALE	N.T.S.	REV.	B	
REFERENCE :				
H03VVH2-F 2X0.75mm ² LF				

2. PLUG

REV	DESCRIPTION	DATE
Q	ADD CATALOGUE NO. 'SSEU2.5SA2'.	24/03/17
R	ADD CATALOGUE NO. 'VBEU2.5S2'.	28/06/18

2.1. SCOPE

The plug shall be in accordance with specification EN 50075` Flat non-wirable two-pole plugs, 2.5A 250V, with cord, for the connection of class II-equipment for household and similar purposes.

2.2. CONSTRUCTION

The plug construction shall comply with our catalogue No: M5206, V4206, M4206, EU2.5S2, GPEU2.5S2 , APEU2.5S2 , APEU2.5S2G, APEU2.5BS2G , MFEU2.5S2, VNEU2.5S2, SSEU2.5SA2 & [VBEU2.5S2](#).

2.3. CHARACTERISTICS

NO.	TEST ITEM	DESCRIPTION	ACCEPTANCE CRITERIA
1.	Moisture resistance test	Samples are kept in a humidity cabinet containing air with a relative humidity between 91 to 95% and a temperature of 20°C-30°C for a duration of 48 hours.	No damage
2.	Electric strength test	A voltage of A.C 2000V with a trip current of min. 100mA is applied for 1 min after the moisture resistance test.	No flashover and breakdown
3.	Insulation resistance test	This test is measured after 1 min. application of D.C 500V after the moisture resistance test.	Min. 5 M Ohm
4.	Temperature rise test	An alternating current of 4A is passed through poles for 1 hour.	The temperature rise at any points shall not exceed 45°.
5.	Bending test	The sample shall be loaded with a weight of 10N for 0.75mm ² or less, or 20N for 1.00mm ² or bigger and the oscillating member shall be moved backward and forward through an angle of 90° (45° on either side of the vertical) the number of flexing being 10,000.The rated current of plug is passed through the conductors.	No damage and the voltage drop shall not exceed 10mV.
6.	Tumbling test	The samples are dropped from a height of 50cm onto a steel plate (3mm thick) for a total of 1000 times. A torque of 0.4Nm is applied in one direction for 1 min. first then follow by the other direction for another min.	No damage and the pins shall not turn.

DRAWN:	LI XIA	28/06/18	TITLE: EUROPEAN PLUG (2.5A 250V)
CHECK:	<i>Feng</i>	28/06/18	
APPR:	<i>heith</i>	28/06/18	
REV:	R		

REFERENCE:	
------------	--

NO.	TEST ITEM	DESCRIPTION	ACCEPTANCE CRITERIA
7.	Cold impact test	The samples are kept in a refrigerator at a temperature of $-15\pm 2^{\circ}\text{C}$ for at least 16 hours. The samples are then allowed to fall by the hammer (1000g) from a height of 10cm.	No damage
8.	Abrasion test	The pin of sample slopes downwards at angle of 10° to the horizontal. The sample is loaded with a force of 4N on the pin. The number of movement is 20,000 and the length of pin subjected to abrasion is approx. 7mm over the insulating collar.	No damage
9.	Heat deformation test	The samples are kept for 1 hour in a heating cabinet at temperature of $100\pm 5^{\circ}\text{C}$.	No damage
10.	Heat pressure test	The samples are applied 20N (2.04kg) at a temperature of $80\pm 2^{\circ}\text{C}$ for 1 hour.	No damage
11.	Ageing test	The samples are kept for 168 hours in a heating cabinet at temperature of $80\pm 2^{\circ}\text{C}$.	No damage
12.	Pressure test	The samples are applied a force of 150N for 5 mins at room temperature. The samples are then allowed to rest for 15 mins.	No damage and dimension changes to the plug.
13.	Cord-anchorage test	The cord is subjected to pulls of 50N (2.5A) or 60N (10/16A) force 100 times with jerk each lasting 1 sec. Thereafter the cord is subjected to a torque of 0.1Nm for 0.5mm^2 and 0.15Nm for 0.75mm^2 or more for 1 min.	The cord shall not be damaged and shall not been displaced by more than 2mm.
14.	Pin pull test	The plug is placed in an oven of $70\pm 2^{\circ}\text{C}$ for 1 hour. A pull force of 40N is applied on the pins in turns. After the test, the plug is allowed to cool down to ambient temperature	The pin shall not have been displaced by more than 1mm.
15.	Ball pressure test	A steel ball of 5mm in diameter is applied with 20N force on the sample at a temperature of $125\pm 5^{\circ}\text{C}$ for 1 hour on the insert.. The sample is than cooled by cold water.	The diameter of the impression shall not exceed 2mm.
16.	Glow wire test	The tip of the glow wire heated electrically to $750\pm 10^{\circ}\text{C}$ shall be applied at the portion between the current-carrying pins for a period of 30s.	Any flame and glowing shall extinguish within 30s after the removal of the glow-wire. There shall be no ignition of the tissue paper or scorching of the board.

DRAWN:	LI XIA	28/06/18	TITLE: EUROPEAN PLUG (2.5A 250V)
CHECK:	<i>Feng</i>	28/06/18	
APPR:	<i>Keith</i>	28/06/18	
REV:	R		
REFERENCE:			

3. CONNECTOR

REV	DESCRIPTION	DATR
AE	ADD IN CATALOGUE NO. 'VNBC7S' .	27/06/19
AF	ADD IN CATALOGUE NO. 'VNBC7SL' .	07/08/19

3.1. SCOPE

The connector shall be in accordance with IEC 60320-1 or EN 60320-1,
Test specification - appliance couplers.

3.2. CONSTRUCTION

The connector construction shall comply with our catalogue No: VAC7S, VAC7A, SZC7S, APC7S, APC7Q, DLC7U2, AP7M16, SOC7S, VCC7, APC7K, APC7H, MFC7S, VAC7EA, APC7HB, VNC7S, VNC7A, VAC7SR, VBC7A & VNBC7S
VNBC7SL " All Connectors complying to Standard Sheet C7"

3.3. CHARACTERISTICS

NO.	TEST ITEM	DESCRIPTION	ACCEPTANCE CRITERIA
1.	Moisture resistance test	Samples are kept in a humidity cabinet containing air with a relative humidity between 91 to 95% and a temperature of 20°C-30°C for a duration of 48 hours.	No damage
2.	Electric strength test	Voltages of 3000V±60V and 1500V±60V, with min. trip current of 100mA is applied for 60s±5s between current-carrying contacts and body and between each contacts respectively after the moisture resistance tests.	No flashover and breakdown
3.	Insulation resistance test	This test is measured with a D.C 500V after the moisture resistance test. Readings are taken after 60s ± 5s of application of voltage.	Min. 5 M Ohm
4.	Withdrawal force test	i) Min. 1.5N (2N for 16A) - A single pin made to the minimum dimension is inserted into the connector. The pin, together with the weight should exert a force of 1.5N (2N for 16A connector). Each individual pole of the connector is tested separately. ii) Max. 50N (60N for 16A) - Insert and withdraw the connector from a socket having pin dimension to the maximum and shroud dimension to the minimum for 10 times. The connector is then inserted again into the socket hang with a total weight of 50N(60N for 16A). The weight consist of a principal weight which is 90% of the total weight and a supplementary weight of 10%.	i) The pin with the weight should not be withdrawn from the connector for more than 3 seconds. ii) The connector shall be withdrawn from the socket. If not the supplementary weight is lifted from a height of 5cm and drop. The connector must be withdrawn. The test is repeated after temperature rise test.

DRAWN:	PEIYUAN	07/08/19	TITLE : EUROPEAN & BRITISH APPLIANCE COUPLERS
CHECK:	Peiyuan	07/08/19	
APPR:	Jianying	07/08/19	
REV:	AF		
REFERENCE:			

NO.	TEST ITEM	DESCRIPTION	ACCEPTANCE CRITERIA
5.	Glow wire test	Glow wire is applied for 30s with temperature of 750°C on inserts and housings retaining contacts and 650°C on elsewhere.	Flame (if any) shall be self-extinguished within 30s . upon the removal of the glow wire and molten droplets shall not ignite paper.
6.	Bending test	The sample shall be loaded with a weight of 10N for 0.75mm ² or less, or 20N for 1.00mm ² or bigger and the oscillating member shall be moved backward and forward through an angle of 90°(45° on either side of the vertical) the number of flexing being 20,000.A rated current is applied. For round cord, the sample is turned 90 degree around the axis of cable after 10,000 cycles. The flexing is further completed in this axis. Flat cable is flexed only along the bigger axis of the cable.	There shall be no complete breakage of any of the conductor. Broken conductor shall not have pierced the insulation
7.	Tumbling test	The sample is dropped from a height of 50cm onto a steel plate(3mm thick) for a total of 500 times.	No damage to impair further use of connector.
8.	Breaking capacity test	The connector is connected and disconnected 50 times (100 strokes) with the inlet at a rate of 30 strokes per minute with 275V and 1.25 times of rated current.	No flashover or sustained arcing during the test and no damage to impair further use of connector.
9.	Normal operation test	Test is similar to breaking capacity except that the test voltage is 250V with the connector connected and disconnected with the inlet for 1000 times (2000 strokes) with rated current and 3000 times (6000 strokes) without current.	Withstand electric strength at 1500V for 1 min, and show no damage.
10.	Temperature rise test	An alternating current at 1.25 times rated current is passed through the current carrying contacts for 1 hour.This is repeated for connector with earth contact passing current between earth and each of the current carrying contacts.	The temperature rise shall not exceed 45K.
11.	Cord-anchorage test	The cord is subjected to pulls of 50N(2.5A) or 60N(others) for 100 times each time for 1 sec. without jerk.Thereafter the cord is subjected for 1 min. to a torque of 0.1Nm(0.50mm ²) or 0.15Nm(0.75mm ²) or 0.25Nm(others).	The cord shall not be damaged and shall not be displaced by more than 2mm.
12.	Heat deformation test	Samples are kept for 1 hour in a heating cabinet at temperature of 100±2°C.	No damage to impair further use of connector.
13.	Heat pressure test	A pressure of 20N is applied at a temperature of 100°C ± 2°C for 1 hour.	No damage to impair further use of connector.

DRAWN:	PEIYUAN	07/08/19
CHECK:	Peiyuan	07/08/19
APPR:	Jianying	07/08/19
REV:	AF	

TITLE :
EUROPEAN & BRITISH
APPLIANCE COUPLERS

REFERENCE:

NO.	TEST ITEM	DESCRIPTION	ACCEPTANCE CRITERIA
14.	Aging test	The samples are kept for 168 hours in a heating cabinet at a temperature of 80±2°C.	No damage & marking shall be legible.
15.	Ball pressure test	A ball of 5mm in diameter is applied on the connector with the following temperature with 20N force for 1 hour. i) 125°C for hot connectors. ii) 125°C for parts retaining current carrying parts and earth circuit. iii) 75°C for other parts for cold connector. The connector is then cooled down to room temperature with cold water.	The diameter of the impression shall not exceed 2mm.
16.	Deformation test	Rectangular blades(A &B) as specified in IEC/EN60320-1 fig.22 are used to apply pressure on the front portion of the connector.Blade A is applied on the side with groove with 10N force. Blade B is applied on the side of the connector with 5N force.The force is applied at a temperature of 70°C±2°C for 2 hours.The connector is then cooled down to room temperature with cold water.	The impression shall not be greater than 0.2mm.

DRAWN:	PEIYUAN	07/08/19	TITLE : EUROPEAN & BRITISH APPLIANCE COUPLERS
CHECK:	Peiyuan	07/08/19	
APPR:	Jianying	07/08/19	
REV:	AF		
REFERENCE:			

REV.	DESCRIPTION	DATE
A	INITIAL RELEASE.	30/03/15

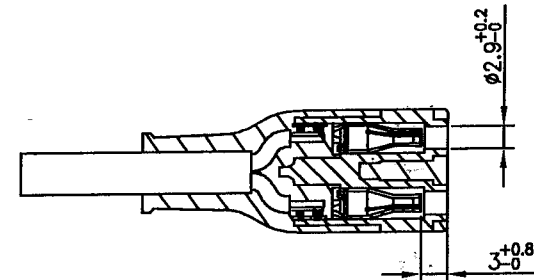
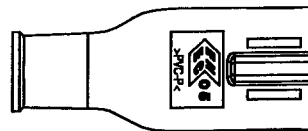
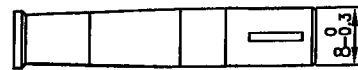
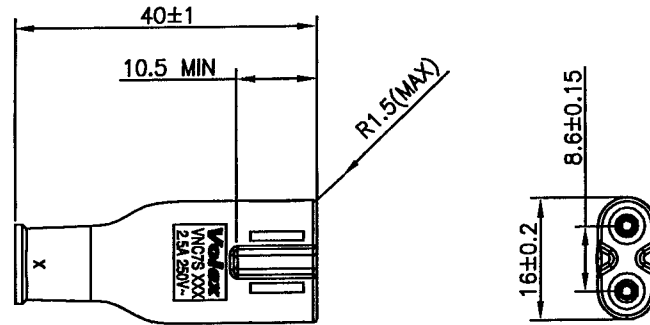

Volex
VNC7S XXX
2.5A 250V~

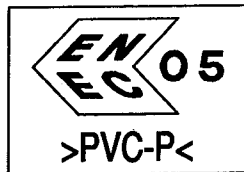

MARKING DETAILS :

NOTES :

- 1.) ALL DIMENSIONS IN mm.
- 2.) X - CAVITY NO. (OPTIONAL)
- 3.) XXX - MANUFACTURING LOCATION.

HG	HENG GANG (CHINA)		DRAWN	HUI QIONG	30/03/15	FILE NAME :	TITLE : MOLDED CONNECTOR VNC7S	
SM1/SMI	ZHONGSHAN (CHINA)	X	CHECK	Hui Qiong	30/03/15	A-CONNECTOR/ EURO/GENERAL/ VNC7S-EURO		
VH	HANOI (VIETNAM)		APPR	[Signature]	31/3/15	N.T.S.		
B	BATAM (INDONESIA)		REV.	A	SCALE			
VC	CHENNAI (INDIA)		REFERENCE :					
MANUFACTURE LOCATION MARK (* X * IS APPLICABLE ONLY)			EUROPEAN APPROVAL					