

# Datasheet

EN

## Product overview

A range of high frequency EMC compliant enclosures for shielding electronic equipment.

- Lid and base moulded in ABS
- Graphite dark grey paint finish
- Electromagnetic compatibility EMC coating
- Lid mounted by four M3 machine screws
- Brass inserts in base for repeated removal of the lid
- Excellent properties for machining
- Integral mounting guides to accept 1.6mm PCBs
- PCB adaptors (not included) for horizontal PCB mounting
- 2000 series has been designed to meet the requirements of IP54



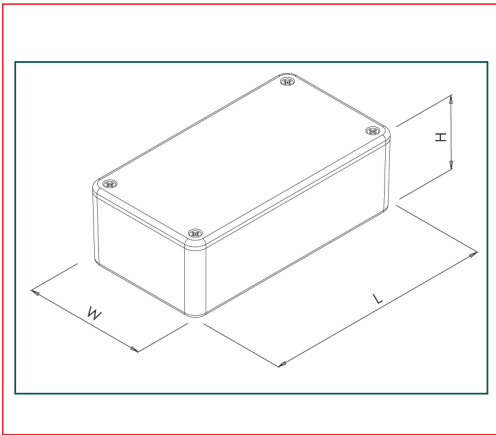

SPECIFICATION	
Materials	Lid and base high impact ABS
Operating temperature	Resistant to temperatures of up to 80°C
Standard colours	Graphite dark grey
Protection class	2000 series has been designed to meet the requirements of IP54
Standard unit includes	Base and lid 4x M3 machine screws

GREY	LENGTH	WIDTH	HEIGHT
1533206	190mm	110mm	60mm