

Panasonic

ideas for life

LC-V064R5

For standby power supplies
 Expected trickle life: 3 years at 25°C
 5 years at 20°C



※Contents indicated (including the recycle marking, etc) are subject to change without notice.

■Dimensions(mm)

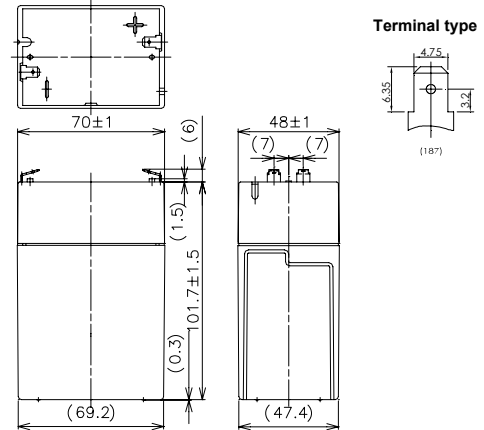

Battery case resin: Flame-retardant (UL94V-0)

■Specification

Nominal Voltage	6V	
Rated Capacity(20HR)	4.5Ah	
Dimensions	Length	70 mm
	Width	48 mm
	Height	102 mm
	Total height	108 mm
Approx. Mass	0.70 kg	
Terminal	Faston 187	

■Characteristics

Capacity (25 °C)	20 hour rate	4.5Ah
	10 hour rate	4.0Ah
	3 hour rate	3.6Ah
	1 hour rate	3.0Ah
Internal Resistance (25 °C)	Fully charged battery	20 mΩ
Temperature Dependency of Capacity (20 hour rate)	40 °C	102%
	25 °C	100%
	0 °C	85%
	-15 °C	65%
Self Discharge (25 °C)	After 3 months	91%
	After 6 months	82%
	After 12 months	64%

■Duration of discharge vs. discharge current

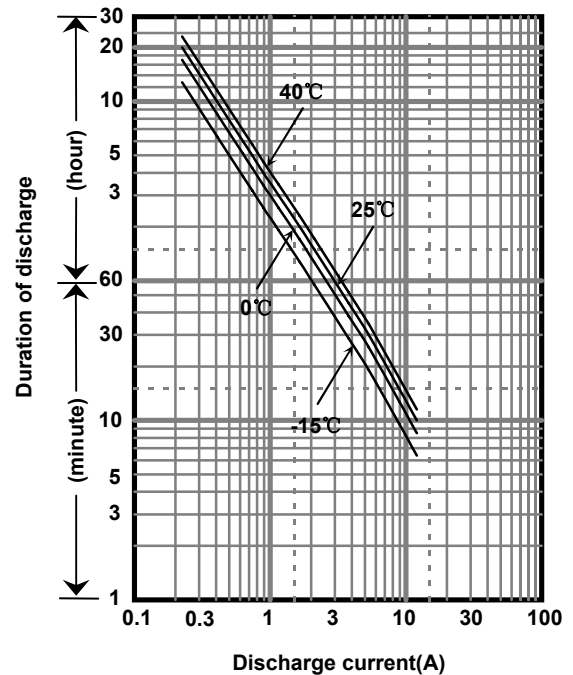

■Watt Table(25°C)

Cut-off V	3min	5min	10min	15min	20min	30min	45min	1h	1.5h	2h	3h	4h	5h	6h	10h	20h
4.80V	135	107	69.7	53.2	44.6	33.3	23.5	18.8	12.9	9.99	7.44	5.71	4.72	3.79	2.51	1.36
4.95V	125	100	68.3	52.8	43.9	32.9	23.3	18.6	12.7	9.92	7.40	5.68	4.68	3.78	2.50	1.36
5.10V	116	93.7	66.5	51.8	43.1	32.5	23.1	18.4	12.4	9.66	7.33	5.64	4.64	3.75	2.48	1.35
5.25V	103	84.0	61.6	48.2	41.0	31.8	22.7	18.0	12.1	9.32	7.21	5.60	4.60	3.70	2.46	1.35
5.40V	86.9	74.2	55.0	44.9	39.9	30.7	22.4	17.7	11.8	8.88	7.07	5.53	4.49	3.64	2.44	1.34

■Ampere Table(25°C)

Cut-off V	3min	5min	10min	15min	20min	30min	45min	1h	1.5h	2h	3h	4h	5h	6h	10h	20h
4.80V	24.3	19.1	12.4	9.25	7.69	5.69	4.00	3.19	2.19	1.69	1.25	0.956	0.788	0.633	0.419	0.227
4.95V	22.6	17.9	12.2	9.19	7.56	5.63	3.98	3.16	2.14	1.68	1.24	0.950	0.781	0.630	0.417	0.226
5.10V	20.8	16.8	11.9	9.00	7.44	5.56	3.94	3.13	2.10	1.63	1.23	0.944	0.775	0.625	0.413	0.226
5.25V	18.5	15.1	11.0	8.38	7.06	5.44	3.88	3.06	2.06	1.58	1.21	0.938	0.769	0.618	0.411	0.225
5.40V	15.6	13.3	9.81	7.81	6.88	5.25	3.81	3.00	2.00	1.50	1.19	0.925	0.750	0.608	0.406	0.224

Charging Method (25°C)

Trickle use	Control voltage: 6.80-6.90V Initial current: 0.675A or smaller
-------------	---

Cut off voltage

Discharge current	0.225A-0.900A	0.900A-2.25A	2.25A-4.50A	4.50A-9.00A	9.00A-13.5A
Cut off voltage(V)	5.25	5.10	4.95	4.65	4.35

Influence of Temperature on Trickle life

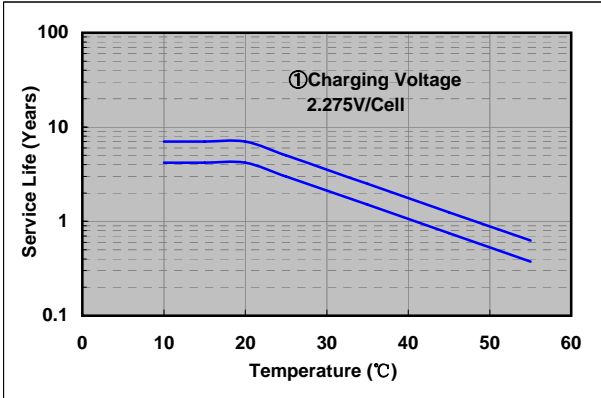

Residual capacity test result

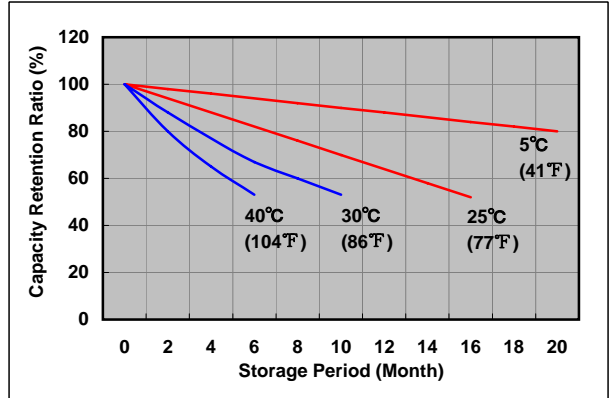

Constant-voltage constant-current charge characteristics for Trickle use

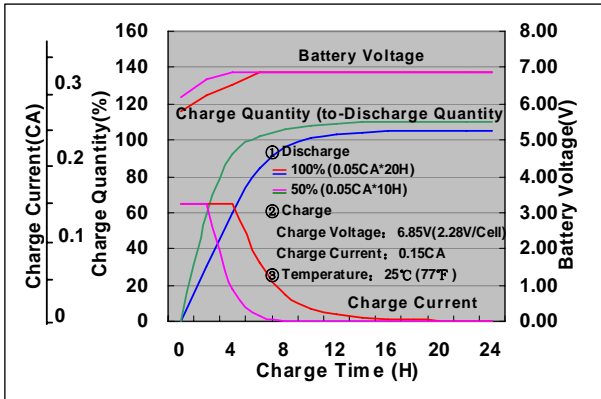

Discharge capacity by temperature and by discharge current

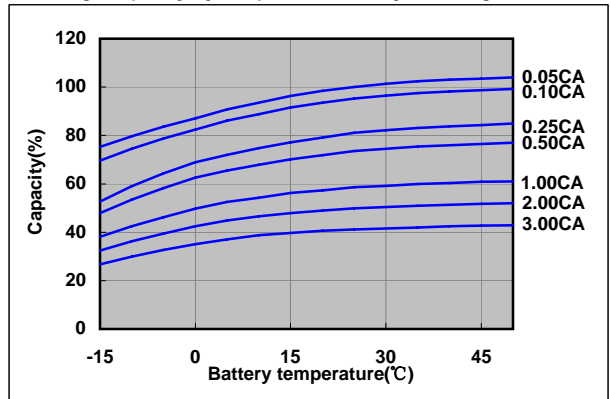

Discharge characteristics(25°C)

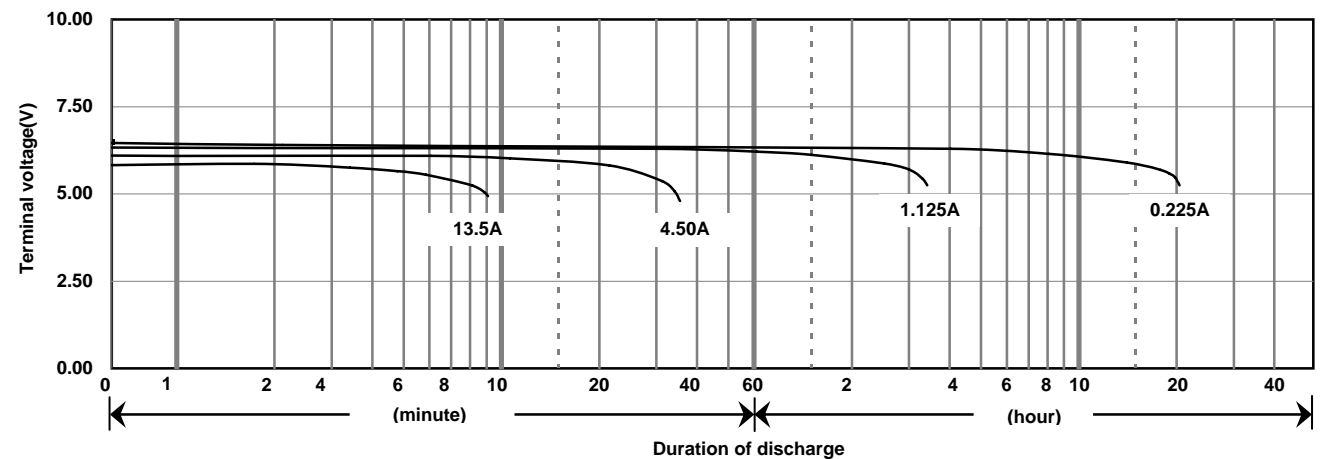

Caution

Due to the potential energy stored in the batteries, Please read 《Precautions for handling the Rechargeable Valve Regulated Lead Acid Batteries》 before using batteries. If improper handling or use of the batteries without understanding 《Precautions for handling the Rechargeable Valve Regulated Lead Acid Batteries》 may result in bodily injury caused by electrolyte leakage, heat generation, or explosion.

Panasonic Storage Battery (Shenyang) Co., Ltd

NO. 51 Kunminghu Street, Shenyang Economic & Technical Development Zone, 110141 China
Tel: 86 24 25818921
Fax: 86 24 62786318
Website: <http://www.panasonicbattery.cn>

2010.03