

1/2" DIAPHRAGM PUMP 1:1 RATIO (METALLIC)



**READ THIS MANUAL CAREFULLY BEFORE INSTALLING,
 OPERATING OR SERVICING THIS EQUIPMENT.**

It is the responsibility of the employer to place this information in the hands of the operator. Keep for future reference.

SERVICE KITS

Refer to Model Description Chart to match the pump material options.
 637140-XX for fluid section repair (see page 4).
 637141 for air section repair (see page 6).

PUMP DATA

Models..... see Model Description Chart for "-XXX"
Pump Type..... Air Operated Double Diaphragm
Material..... see Model Description Chart
Weight..... PD05P-AAS-XXX 8.36 lbs (3.79 kgs)
 PD05P-ASS-XXX..... 14.6 lbs (6.62 kgs)
Maximum Air Inlet Pressure 100 psig (6.9 bar)
Maximum Material Inlet Pressure... 10 psig (0.69 bar)
Maximum Outlet Pressure 100 psig (6.9 bar)
Air Consumption @ 40 psig 1 cfm / gallon (approx.)
Maximum Flow Rate (flooded inlet) ... 13 gpm (49.2 lpm)
Displacement / Cycle @ 100 psig... 0.040 gal. (0.15 lit.)
Maximum Particle Size 3/32" dia. (2.4 mm)
Maximum Temperature Limits (Diaphragm / Ball / Seat material)
 Nitrile 10° to 180° F (-12° to 82° C)
 Polypropylene 32° to 175° F (0° to 79° C)
 Santoprene® -40° to 225° F (-40° to 107° C)
 PTFE 40° to 225° F (4° to 107° C)
 Viton® -40° to 350° F (-40° to 177° C)
Dimensional Data..... see page 8
Noise Level @ 70 psig, 60 cpm..... 71.1 dB(A)^①

① The pump sound pressure levels published here have been updated to an Equivalent Continuous Sound Level (LA_{eq}) to meet the intent of ANSI S1.13-1971, CAGI-PNEUROP S5.1 using four microphone locations.

NOTICE: All possible options are shown in the chart, however, certain combinations may not be recommended, consult a representative or the factory if you have questions concerning availability.

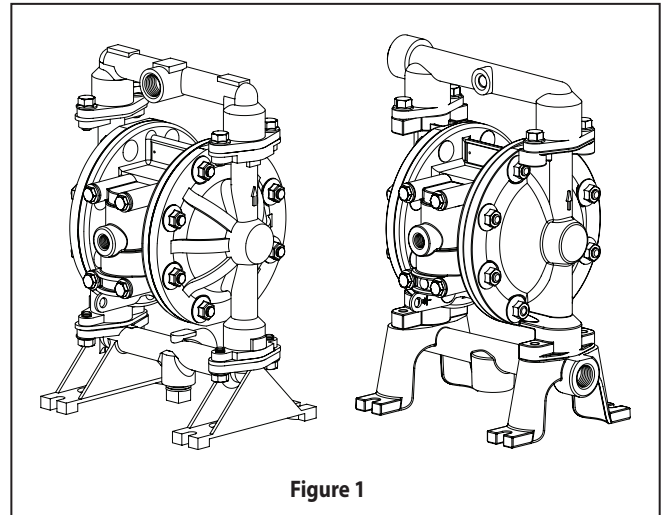

Figure 1

MODEL DESCRIPTION CHART

PD05 P - A X S - X X X		
Center Section Material P - Polypropylene		
Fluid Connection A - 1/2 - 14 NPTF - 1		
Fluid Cap & Manifold Material A - Aluminum S - Stainless Steel		
Hardware Material S - Stainless Steel		
Seat Material F - Aluminum P - Polypropylene S - Stainless Steel		
Ball Material A - Santoprene G - Nitrile S - Stainless Steel T - PTFE V - Viton		
Diaphragm Material A - Santoprene G - Nitrile L - Long Life PTFE T - PTFE / Santoprene V - Viton		
Fluid Section Service Kit Selection		
PD05P - A X S - X X X 637140 - <input checked="" type="checkbox"/> <input checked="" type="checkbox"/> EXAMPLE: Model #PD05P-ASS-SAA Fluid Section Service Kit # 637140-AA		Ball <input type="checkbox"/> Diaphragm <input type="checkbox"/>

OPERATING AND SAFETY PRECAUTIONS

READ, UNDERSTAND AND FOLLOW THIS INFORMATION TO AVOID INJURY AND PROPERTY DAMAGE.



WARNING EXCESSIVE AIR PRESSURE. Can cause personal injury, pump damage or property damage.

- Do not exceed the maximum inlet air pressure as stated on the pump model plate.
- Be sure material hoses and other components are able to withstand fluid pressures developed by this pump. Check all hoses for damage or wear. Be certain dispensing device is clean and in proper working condition.

WARNING STATIC SPARK. Can cause explosion resulting in severe injury or death. Ground pump and pumping system.

- Use the pump ground lug provided. Connect to a 12 ga. (minimum) wire (kit is included) to a good earth ground source.
- Sparks can ignite flammable material and vapors.
- The pumping system and object being sprayed must be grounded when it is pumping, flushing, recirculating or spraying flammable materials such as paints, solvents, lacquers, etc. or used in a location where surrounding atmosphere is conducive to spontaneous combustion. Ground the dispensing valve or device, containers, hoses and any object to which material is being pumped.
- Secure pump, connections and all contact points to avoid vibration and generation of contact or static spark.
- Consult local building codes and electrical codes for specific grounding requirements.
- After grounding, periodically verify continuity of electrical path to ground. Test with an ohmmeter from each component (e.g., hoses, pump, clamps, container, spray gun, etc.) to ground to ensure continuity. Ohmmeter should show 0.1 ohms or less.
- Submerge the outlet hose end, dispensing valve or device in the material being dispensed if possible. (Avoid free streaming of material being dispensed.)
- Use hoses incorporating a static wire.
- Use proper ventilation.
- Keep inflammables away from heat, open flames and sparks.
- Keep containers closed when not in use.

WARNING Pump exhaust may contain contaminants. Can cause severe injury. Pipe exhaust away from work area and personnel.

- In the event of a diaphragm rupture, material can be forced out of the air exhaust muffler.
- Pipe the exhaust to a safe remote location when pumping hazardous or inflammable materials.
- Use a grounded 3/8" minimum ID hose between the pump and the muffler.

WARNING HAZARDOUS PRESSURE. Can result in serious injury or property damage. Do not service or clean pump, hoses or dispensing valve while the system is pressurized.

- Disconnect air supply line and relieve pressure from the system by opening dispensing valve or device and

/ or carefully and slowly loosening and removing outlet hose or piping from pump.

WARNING HAZARDOUS MATERIALS. Can cause serious injury or property damage. Do not attempt to return a pump to the factory or service center that contains hazardous material. Safe handling practices must comply with local and national laws and safety code requirements.

- Obtain Material Safety Data Sheets on all materials from the supplier for proper handling instructions.

WARNING EXPLOSION HAZARD. Models containing aluminum wetted parts cannot be used with 1,1,1-trichloroethane, methylene chloride or other halogenated hydrocarbon solvents which may react and explode.

- Check pump motor section, fluid caps, manifolds and all wetted parts to assure compatibility before using with solvents of this type.

CAUTION Verify the chemical compatibility of the pump wetted parts and the substance being pumped, flushed or recirculated. Chemical compatibility may change with temperature and concentration of the chemical(s) within the substances being pumped, flushed or circulated. For specific fluid compatibility, consult the chemical manufacturer.

CAUTION Maximum temperatures are based on mechanical stress only. Certain chemicals will significantly reduce maximum safe operating temperature. Consult the chemical manufacturer for chemical compatibility and temperature limits. Refer to PUMP DATA on page 1 of this manual.

CAUTION Be certain all operators of this equipment have been trained for safe working practices, understand it's limitations, and wear safety goggles / equipment when required.

CAUTION Do not use the pump for the structural support of the piping system. Be certain the system components are properly supported to prevent stress on the pump parts.

- Suction and discharge connections should be flexible connections (such as hose), not rigid piped, and should be compatible with the substance being pumped.

CAUTION Prevent unnecessary damage to the pump. Do not allow pump to operate when out of material for long periods of time.

- Disconnect air line from pump when system sits idle for long periods of time.

CAUTION Use only genuine ARO® replacement parts to assure compatible pressure rating and longest service life.

NOTICE Install the pump in the vertical position. The pump may not prime properly if the balls do not check by gravity upon start-up.

NOTICE Re-torque all fasteners before operation. Creep of housing and gasket materials may cause fasteners to loosen. Re-torque all fasteners to ensure against fluid or air leakage.

NOTICE Replacement warning labels are available upon request: "Static Spark" pn \ 93616-1, Diaphragm Rupture" pn \ 93122.

- ⚠ WARNING** = Hazards or unsafe practices which could result in severe personal injury, death or substantial property damage.
- ⚠ CAUTION** = Hazards or unsafe practices which could result in minor personal injury, product or property damage.
- NOTICE** = Important installation, operation or maintenance information.

GENERAL DESCRIPTION

The ARO diaphragm pump offers high volume delivery even at low air pressure and a broad range of material compatibility options are available. Refer to the model and option chart. ARO pumps feature stall resistant design, modular air motor / fluid sections.

Air operated double diaphragm pumps utilize a pressure differential in the air chambers to alternately create suction and a positive fluid pressure in the fluid chambers, ball checks ensure a positive flow of fluid.

Pump cycling will begin as air pressure is applied and it will continue to pump and keep up with the demand. It will build and maintain line pressure and will stop cycling once maximum line pressure is reached (dispensing device closed) and will resume pumping as needed.

AIR AND LUBE REQUIREMENTS

- ⚠ WARNING EXCESSIVE AIR PRESSURE. Can cause pump damage, personal injury or property damage.**
- A filter capable of filtering out particles larger than 50 microns should be used on the air supply. There is no lubrication required other than the "O" ring lubricant which is applied during assembly or repair.
 - If lubricated air is present, make sure that it is compatible with the "O" rings and seals in the air motor section of the pump.

OPERATING INSTRUCTIONS

- Always flush the pump with a solvent compatible with the material being pumped if the material being pumped is subject to "setting up" when not in use for a period of time.
- Disconnect the air supply from the pump if it is to be inactive for a few hours.
- The outlet material volume is governed not only by the air supply, but also by the material supply available at the inlet. The material supply tubing should not be too small or restrictive. Be sure not to use hose which might collapse.
- When the diaphragm pump is used in a forced-feed (flooded inlet) situation, it is recommended that a "check valve" be installed at the air inlet.
- Secure the diaphragm pump legs to a suitable surface to ensure against damage by vibration.

MAINTENANCE

- Certain ARO "Smart Parts" are indicated which should be available for fast repair and reduction of down time.
- Provide a clean work surface to protect sensitive internal moving parts from contamination from dirt and foreign matter during service disassembly and reassembly.
- Keep good records of service activity and include the pump in preventive maintenance program.
- Service kits are available to service two separate diaphragm pump functions: 1. AIR SECTION, 2. FLUID SECTION. The Fluid Section is divided further to match typical active Material Options.
- Before disassembling, empty captured material in the outlet manifold by turning the pump upside down to drain material from the pump.

TYPICAL CROSS SECTION

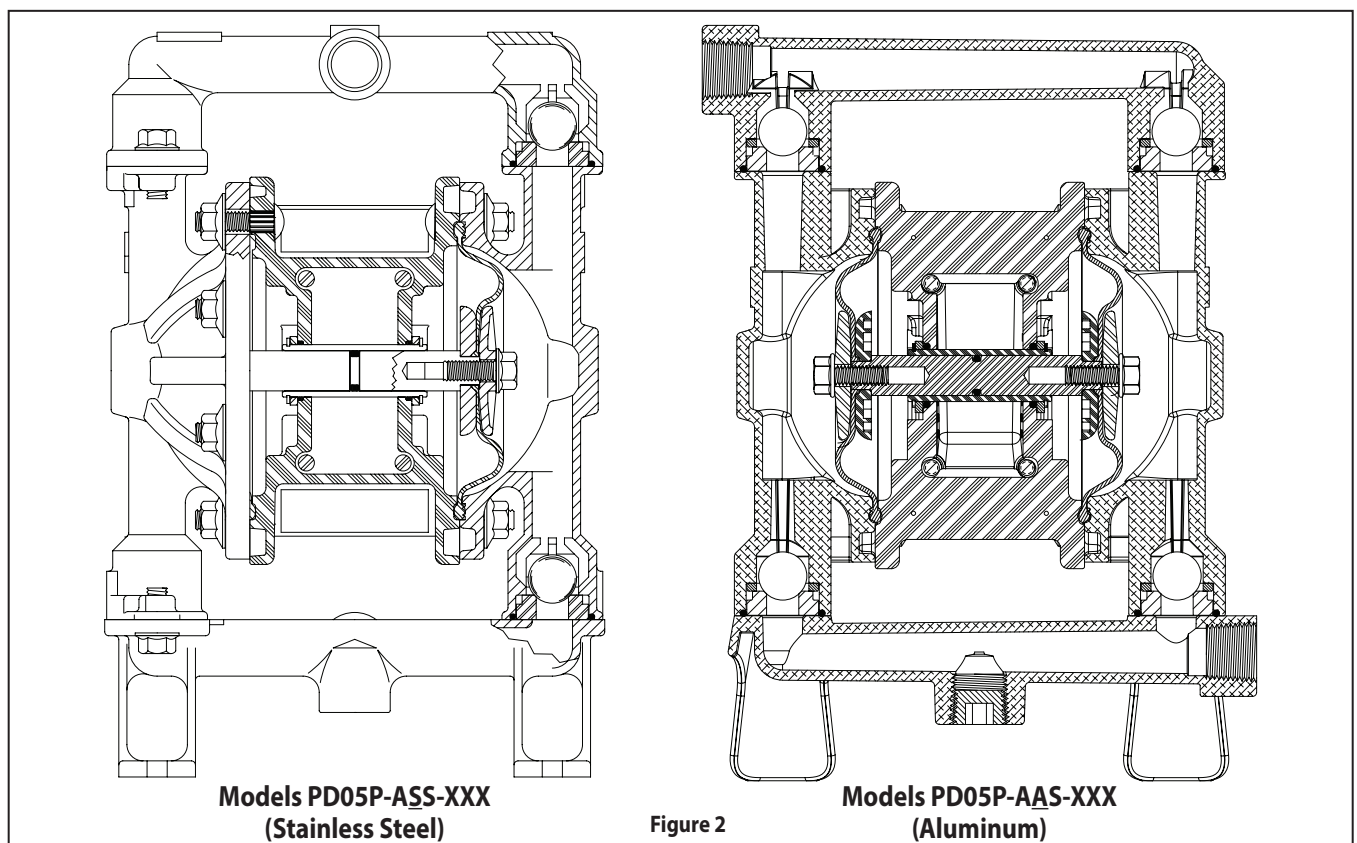

PARTS LIST / PD05P-XXX-XXX FLUID SECTION

★ 637140-XX Fluid Section Service Kits include: Balls (see Ball Option, refer to -XX in chart below), Diaphragms (see Diaphragm Option, refer to -XX in chart below), and items 2 and 19 (listed below) plus 93706-1 Key-Lube grease packet (page 6).

SEAT OPTIONS PD05P-AXS-XXX				BALL OPTIONS PD05P-AXS-XXX						
★ "21"				★ "22" (3/4" diameter)				★ "19" (3/32" x 1-5/16" OD)		
-XXX	Seat	Qty	[Mtl]	-XXX	Ball	Qty	[Mtl]	"O" Ring	Qty	[Mtl]
-FXX	95727	(4)	[A]	-XAX	93100-E	(4)	[Sp]	93763	(4)	[E]
-PXX	93098-10	(4)	[P]	-XGX	93100-2	(4)	[B]	Y325-122	(4)	[B]
-SXX	93409-1	(4)	[SS]	-XSX	93410-1	(4)	[SS]	93764	(4)	[F]
				-XTX	93100-4	(4)	[T]	93265	(4)	[T]
				-XVX	93100-3	(4)	[V]	Y327-122	(4)	[V]

MATERIAL CODE	
[A]	= Aluminum
[B]	= Nitrile
[C]	= Carbon Steel
[E]	= E.P.R.
[F]	= Flouraz®
[GFN]	= Glass Filled Nylon
[L]	= Long Life PTFE
[P]	= Polypropylene
[Sp]	= Santoprene
[SS]	= Stainless Steel
[T]	= PTFE
[V]	= Viton

DIAPHRAGM OPTIONS PD05P-AXS-XXX							
-XXX	★ Service Kit	★ "7"			★ "8"		
	-XX = (Ball) -XX = (Diaphragm)	Diaphragm	Qty	[Mtl]	Diaphragm	Qty	[Mtl]
-XXA	637140-XA	93465	(2)	[Sp]	-----	---	---
-XXG	637140-XG	93582-2	(2)	[B]	-----	---	---
-XXL	637140-XL	93111-L	(2)	[L]	93465	(2)	[Sp]
-XXT	637140-XT	93111	(2)	[T]	93465	(2)	[Sp]
-XXV	637140-XV	93581-3	(2)	[V]	-----	---	---

WETTED COMMON PARTS PD05P-AXS-XXX						
Item	Description (size)	Qty	Stainless Steel PD05P-ASS-XXX		Aluminum PD05P-AAS-XXX	
			Part No.	[Mtl]	Part No.	[Mtl]
<input type="checkbox"/> 1	Connecting Rod	(1)	93084	[SS]	93084	[SS]
★ 2	"O" Ring (3/32" x 5/8" OD)	(1)	Y325-111	[B]	Y325-111	[B]
5	Diaphragm Washer (2" OD)	(2)	94645	[GFN]	94645	[GFN]
<input type="checkbox"/> 6	Diaphragm Washer (2" OD)	(2)	94622	[SS]	94622	[SS]
12	Washer	(4)	-----	---	95092	[A]
14	Bolt (5/16" - 18 x 3/4")	(2)	94628	[SS]	94628	[SS]
15	Fluid Cap	(2)	94624	[SS]	95064	[A]
26	Bolt (5/16" - 18 x 3/4")	(8)	94628	[SS]	94628	[SS]
43	Ground Strap	(1)	92956-1	[SS]	92956-1	[SS]
57	Ground Kit Assembly (not shown)	(1)	66885-1	---	66885-1	---
60	Inlet Manifold (bottom)	(1)	94626	[SS]	95065	[A]
61	Outlet Manifold (top)	(1)	94625	[SS]	95066	[A]
62	Flange Nut (5/16" - 18)	(16)	93886	[SS]	93886	[SS]
63	Pipe Plug (1/2 - 14 N.P.T.)	(1)	Y17-13-S	[SS]	Y227-5-L	[C]

"Smart Parts"; keep these items on hand in addition to the service kit for fast repair and reduction of down time.

• Viton® are registered trademarks of the DuPont Company • Flouraz® is a registered trademark of Greene, Tweed and Company •
 • ARO® is a registered trademark of Ingersoll-Rand Company • Santoprene® is a registered trademark of Monsanto Company, licensed to Advanced Elastomer Systems, L.P. •
 • Loctite® is a registered trademark of Henkel Loctite Corporation • 271™ is a trademark of Henkel Loctite Corporation •

PARTS LIST / PD05P-XXX-XXX FLUID SECTION

COLOR CODE		
Material	Diaphragm Color	Ball Color
Nitrile	Black	Red (*)
Santoprene	Tan	Tan
PTFE	White	White
Viton	Yellow (*)	Yellow (*)
		(*) Dot

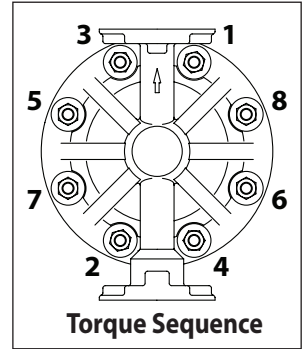

FOR THE AIR MOTOR SECTION, SEE PAGES 6 and 7.

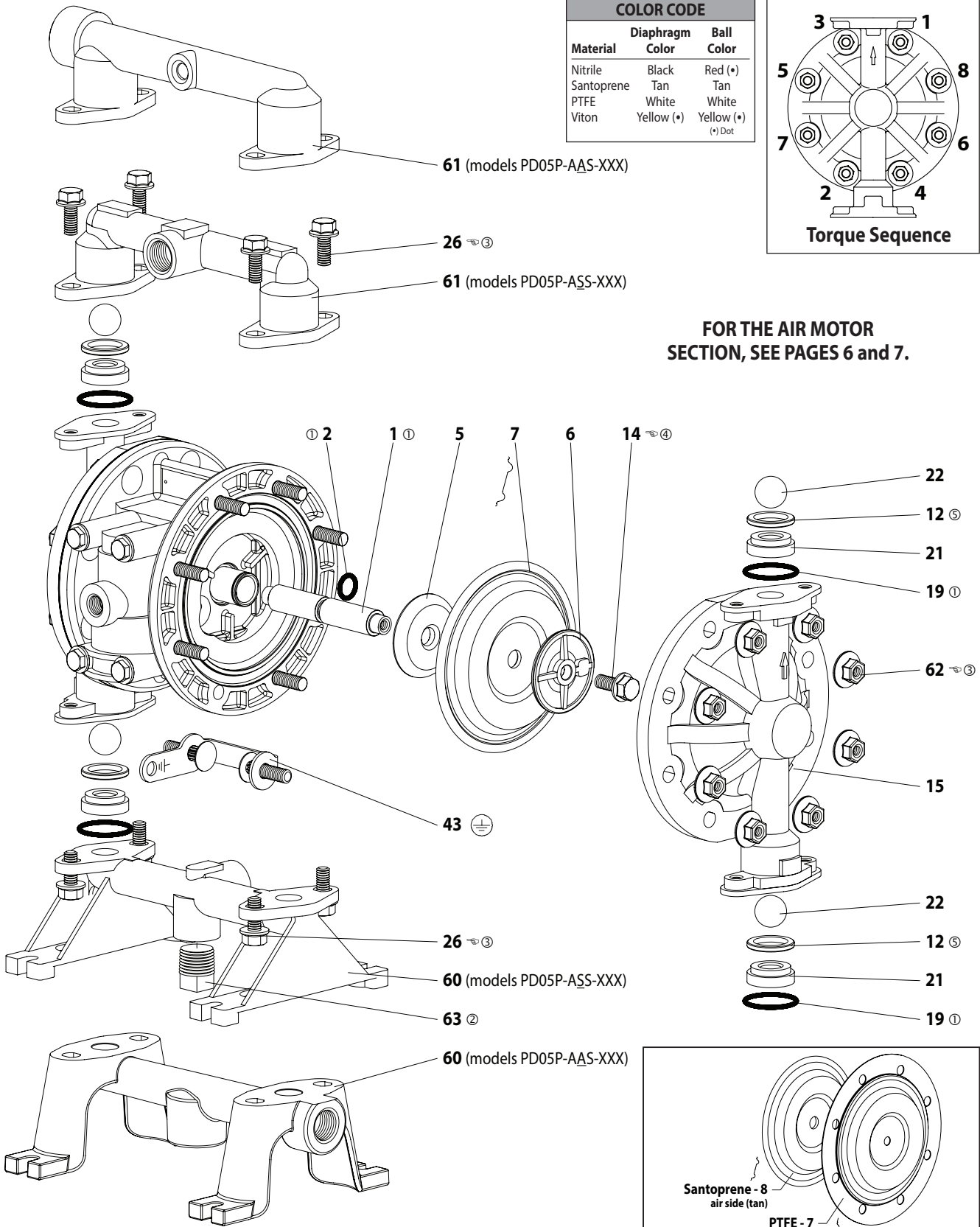

Figure 3

LUBRICATION / SEALANTS

- ① Apply Key-Lube to all "O" rings, "U" cups and mating parts.
- ② Apply pipe sealant to threads.
- ③ Apply anti-seize compound to threads and bolt and nut flange heads which contact pump case when using stainless steel fasteners.
- ④ Apply Loctite® 271™ to threads.
- ⑤ Used on models PD05P-AAS-XXX only.

TORQUE REQUIREMENTS

NOTE: DO NOT OVERTIGHTEN FASTENERS.
 (14) Bolt, 95 - 105 in. lbs (10.7 - 11.9 Nm).
 (26) Bolt, 50 - 60 in. lbs (5.6 - 6.8 Nm), / alternately and evenly, then re-torque after initial run-in.
 (62) Nut, 50 - 60 in. lbs (5.6 - 6.8 Nm), / alternately and evenly, then re-torque after initial run-in.

PARTS LIST / PD05P-XXX-XXX AIR MOTOR SECTION

✓ Indicates parts included in 637141 air section repair kit.

AIR MOTOR PARTS LIST

Item	Description (size)	(Qty)	Part No.	[Mtl]
101	Motor Body	(1)	93091	[P]
✓ 102	"O" Ring (3/32" x 1" OD)	(2)	Y325-117	[B]
□ 103	Sleeve	(1)	93087	[D]
□ 104	Snap Ring (13/16")	(2)	37285	[C]
111	Spool	(1)	93085	[D]
118	Piston	(1)	93088	[C]
✓ 119	"O" Ring (1/8" x 3/4" OD)	(4)	93075	[U]
□ 120	Spacer	(3)	115959	[Z]
✓ 122	Snap Ring (1/2")	(2)	77802	[C]
129	Muffler	(1)	66972	[P]
129	Exhaust Cover (optional)	(1)	93092	[PS]
✓ 130	Gasket	(1)	93107	[SY]
131	Bolt (5/16 - 18 x 1-1/4")	(16)	93095	[SS]
✓ 132	Gasket	(1)	93339-1	[B]

□ "Smart Parts", keep these items on hand in addition to the service kit for fast repair and reduction of down time.

MATERIAL CODE

[B] = Nitrile	[D] = Acetal	[SY] = Syn-Seal
[Bz] = Bronze	[P] = Polypropylene	[U] = Polyurethane
[C] = Carbon Steel	[PS] = Polyester	[Z] = Zinc
[Ck] = Ceramic	[SS] = Stainless Steel	

DIAPHRAGM PUMP SERVICE

GENERAL SERVICE NOTES:

- Inspect and replace old parts with new parts as necessary. Look for deep scratches on metallic surfaces, and nicks or cuts in "O" rings.
- Tools needed to complete disassembly and repair:
 - 1/2" socket or wrench, 7/16" socket or wrench, torque wrench (measuring inch pounds), "O" ring pick.

FLUID SECTION DISASSEMBLY

- Remove (61) top manifold.
- Remove (19) "O" rings, (21) seats, (12) washers (where applicable) and (22) balls.
- Remove (60) bottom manifold.
- Remove (19) "O" rings, (21) seats, (12) washers (where applicable) and (22) balls.
- Remove (15) fluid caps.
- Remove (14) bolt, (6) diaphragm washer, (7) or (7 / 8) diaphragms and (5) washer.
- Remove (1) connecting rod from air motor.
- Carefully remove remaining (14) bolt, (6) diaphragm washer, (7) or (7 / 8) diaphragms and (5) washer from (1) connecting rod. Do not mar surface of connecting rod.
- Remove (2) "O" ring from connecting rod.

Item	Description (size)	(Qty)	Part No.	[Mtl]
133	Washer (9/32" ID)	(4)	93096	[SS]
134	Bolt (1/4" - 20 x 5")	(4)	Y6-419-T	[SS]
135	Valve Block	(1)	93090	[P]
136	Plug	(1)	93086	[D]
✓ 137	"O" Ring (3/32" x 1-1/2" OD)	(1)	Y325-125	[B]
✓ 138	"U" Cup Packing (1/8" x 1" OD)	(1)	94395	[U]
✓ 139	"U" Cup Packing (1/8" x 1-7/16" OD)	(1)	96383	[U]
✓ 140	Valve Insert	(1)	93276	[Ck]
✓ 141	Valve Plate	(1)	93275	[Ck]
142	Washer	(2)	116038	[Z]
143	Plate	(2)	93089	[SS]
201	Muffler (optional)	(1)	93110	[C]
✓	Key-Lube, "O" Ring Lubricant	(1)	93706-1	
	Key-Lube, 10 Pack		637175	

NOTE 1: A major valve service assembly is available separately which includes items 111, 132, 135 - 141. Order part number 66362.

FLUID SECTION REASSEMBLY

- Reassemble in reverse order.
- Lubricate (1) connecting rod and (2) "O" ring with Key-Lube "O" ring lube.
- Install (5) washers with ID chamfer toward diaphragm.
- When replacing PTFE diaphragms, install the 93465 Santoprene diaphragm behind the PTFE diaphragm.

AIR MOTOR SECTION SERVICE

Service is divided into two parts - 1. Pilot Valve, 2. Major Valve.

- Air Motor Section service is continued from Fluid Section repair.

PILOT VALVE DISASSEMBLY

- Remove (122 and 104) snap rings.
- Remove (143) plates.
- Remove (103) sleeve and (102) "O" rings.
- Remove (118) piston, (142) washers, (119) "O" rings and (120) spacers from (101) motor body.

PILOT VALVE REASSEMBLY

- Assemble (119) "O" rings, (120) spacers and (142) washers on (118) piston.
- Insert the stack into the (101) body. (103) sleeve may be used to assist pressing stack into body.
- Install (103) sleeve and (102) "O" rings into (101) body.
- Install (143) plates and (122 and 104) snap rings.

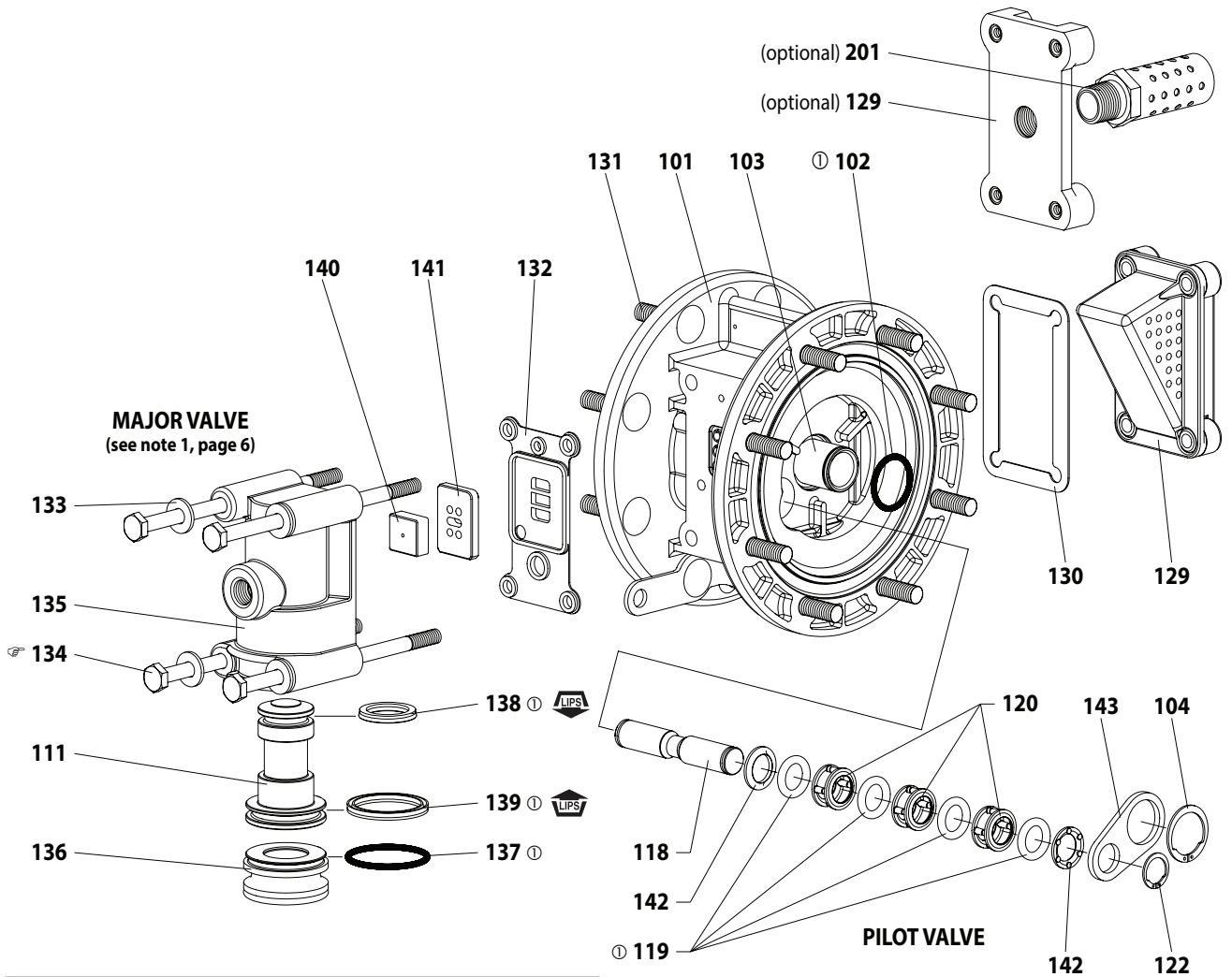

TORQUE REQUIREMENTS
NOTE: DO NOT OVERTIGHTEN FASTENERS.
 (134) Torque to 15 - 20 in. lbs (1.7 - 2.3 Nm), wait 10 minutes, then re-torque to 15 - 20 in. lbs (1.7 - 2.3 Nm).

LUBRICATION / SEALANTS
 ① Apply Key-Lube to all "O" rings, "U" cups and mating parts.

Figure 4

MAJOR VALVE DISASSEMBLY

1. Remove (129) muffler and (130) gasket.
2. Pull (135) valve block assembly from (101) motor body.
3. Remove (134) bolts, (133) washers and (132) gasket from (135) valve block.
4. Remove (141) valve plate and (140) valve insert.
5. Remove (136) plug and (111) spool.

MAJOR VALVE REASSEMBLY

1. Assemble new (138 and 139) "U" cups on (111) spool - **LIPS MUST FACE EACH OTHER.**
2. Insert (111) spool into (135) valve block.
3. Assemble (137) "O" ring on (106) plug and insert into (135) valve block.
4. Assemble (140) valve insert and (141) valve plate to (135) valve block. **NOTE:** Assemble (140) valve insert with "dished" side toward (141) valve plate. Assemble (141) valve plate with 2 identification dots toward (132) gasket.
5. Assemble (132) gasket, (135) valve block and (129) muffler assembly to (101) motor body, securing with (134) bolts. **NOTE:** Tighten (134) bolts to 15 - 20 in. lbs (1.7 - 2.3 Nm).

TROUBLESHOOTING

Product discharged from air exhaust.

- Check for diaphragm rupture.
- Check tightness of (14) bolt.

Air bubbles in product discharge.

- Check connections of suction plumbing.
- Check "O" rings between intake manifold and fluid caps.
- Check tightness of (14) bolt.

Pump blows air out main exhaust when stalled on either stroke.

- Check "U" cups on (111) spool in major valve.
- Check (141) valve plate and (140) insert for wear.
- Check (103) sleeve and (2) "O" ring on diaphragm connecting rod.
- Check (119) "O" rings on (118) piston for wear.

Low output volume.

- Check air supply.
- Check for plugged outlet hose.
- For the pump to prime itself, it must be mounted in the vertical position so that the balls will check by gravity.
- Check for pump cavitation - suction pipe should be 1/2" minimum or larger if high viscosity fluids are being pumped. Suction hose must be non-collapsible type, capable of pulling a high vacuum.
- Check all joints on the intake manifolds and suction connections. These must be air tight.
- Check for sticking or improperly seating check valves.
- If pump cycles at a high rate or runs erratically, check (119) piston "O" rings for wear.

DIMENSIONAL DATA

Dimensions shown are for reference only, they are displayed in inches and millimeters (mm).

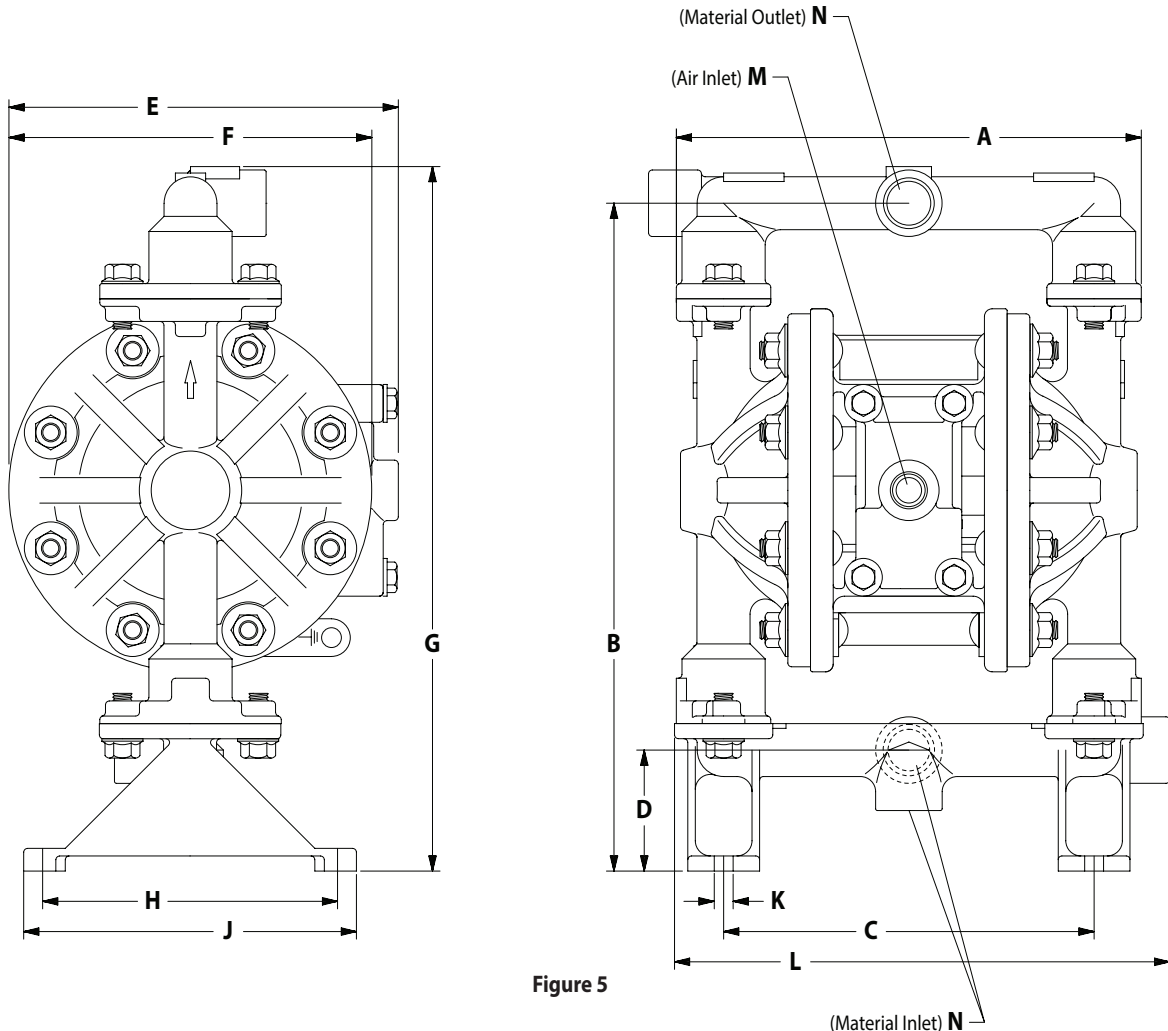

Figure 5

DIMENSIONS

A - 7-11/16" (195.3 mm)
 B - 11-1/32" (280.2 mm)
 C - 6-1/8" (155.6 mm)
 D - 2" (50.8 mm)
 E - 6-7/16" (163.6 mm)

F - 6" (152.4 mm)
 G - 11-5/8" (295.3 mm)
 H - 4-7/8" (123.8 mm)
 J - 5-1/2" (139.7 mm)

K - 5/16" (7.9 mm)
 L - 8-1/4" (209.6 mm)
 M - 1/4 - 18 P.T.F. SAE short
 N - 1/2 - 14 N.P.T.F. - 1