



## Datasheet

# RS PRO - Industrial Raspberry Pi 4 Enclosure - Silver

Stock number: 2309822

EN



### Features:

- Industrial Raspberry Pi enclosure with passive extender board to move the micro HDMI and USB-C connectors onto the same plane as the Raspberry Pi Ethernet and USB connectors.
- The box features dovetail slots down the side which accept a mounting bracket for surface mounting.
- Includes heatsink kit.
- Supplied in kit form - Raspberry Pi not included.

### Kit Contents:

- 8 x M3x10 Taptite Screws
- 14 x M2.5x5 Screws
- 4 x 12mm Standoffs
- 3 x 10mm Standoffs
- 1 x Aluminium End Plate
- 1 x HDMI Extender PCB
- 1 x Aluminium Carrier Plate
- 1 x Aluminium Extrusion - 86.5mm long
- 1 x Acrylic End Plate
- 2 x Heatsink Blocks
- 2 x Thermal Pads
- 2 x M3x5 Screws

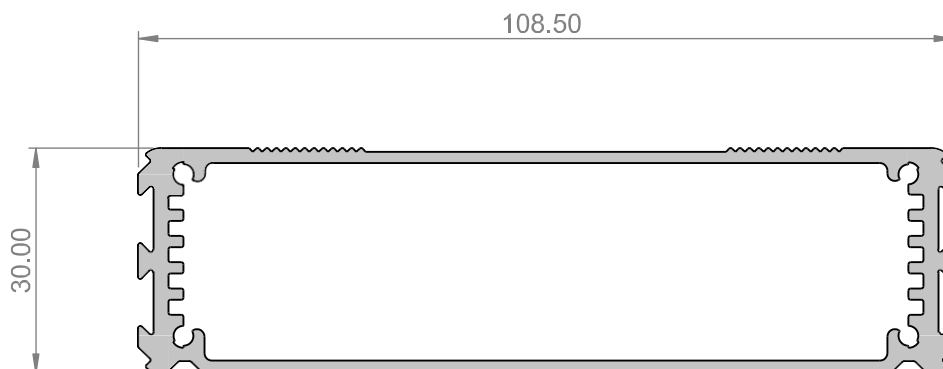



# Datasheet

## Product Description:

### RS PRO - Industrial Raspberry Pi 4 Enclosure - Silver

Industrial Raspberry Pi enclosure with passive extender board to move the micro HDMI and USB-C connectors onto the same plane as the Raspberry Pi Ethernet and USB connectors.

Includes heatsink kit.

Available in Silver or Black anodised finish. Available with optional mounting lugs.

## Specifications:

Item	Material	Finish	Weight
M3x10 Taptite Screws	Steel	Zinc/Black	4.9g (qty 8)
M2.5x5 Screws	Steel	Zinc	4.1g (qty 14)
12mm Standoffs	Nylon	Natural	0.9g (qty 4)
10mm Standoffs	Nylon	Natural	0.7g (qty 3)
Aluminium End Plate	Aluminium 5005	Black Anodised	9.7g
1 x HDMI Extender PCB	FR4	Green	15g
1 x Aluminium Carrier Plate	Aluminium 5005	Raw Aluminium	23.5g
1 x Aluminium Extrusion	Aluminium 6063	Black Anodised	130g
Acrylic End Plate	Acrylic	Black	11.9g
Heatsink Blocks	Aluminium 6082	Natural	6.7g
Thermal Pads	Non-Silicone Gel	Pink	0.4g
M3x5 Scrws	Steel	Zinc	1g

## Kit Contains:

- (a) x8 M3x10 Taptite Screws
- (b) x14 M2.5x5 Screws
- (c) x4 12mm Standoffs
- (d) x3 10mm Standoffs
- (e) x1 Aluminium End Plate
- (f) x1 HDMI Extender PCB
- (g) x1 Aluminium Carrier Plate
- (h) x1 Aluminium Extrusion
- (i) x1 Acrylic End Plate
- (j) x1 Small Heat Block
- (k) x1 Small Heat Pad
- (l) x1 Large Heat Block
- (m) x1 Large Heat Pad
- (n) x2 M3x5 Screws

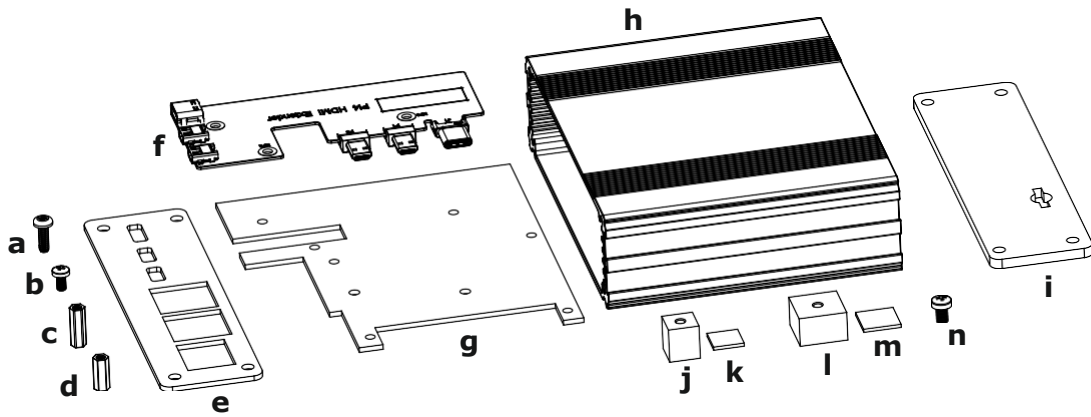

1.

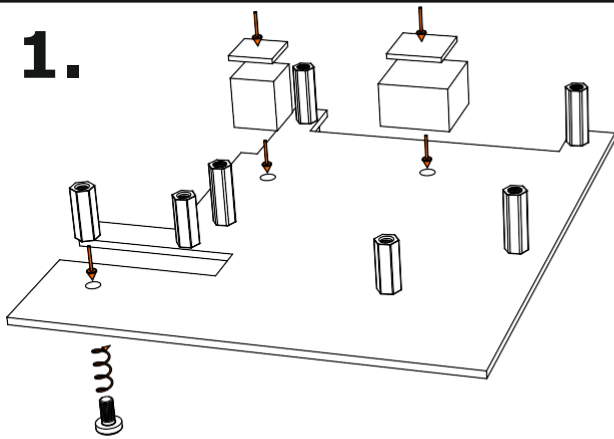

2.

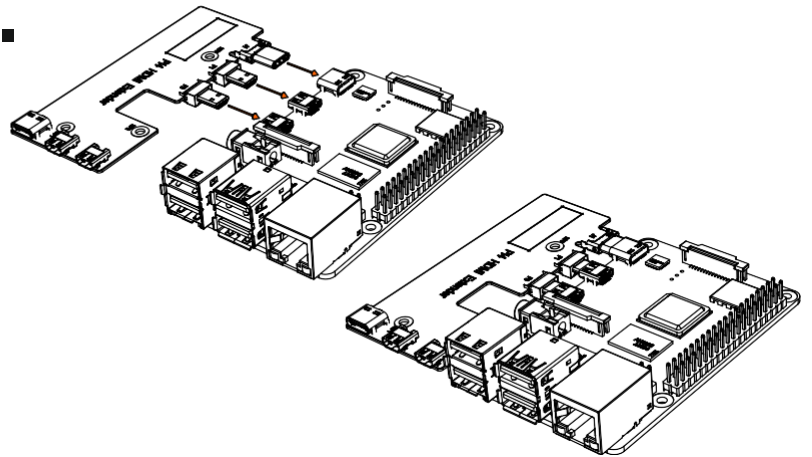

3.

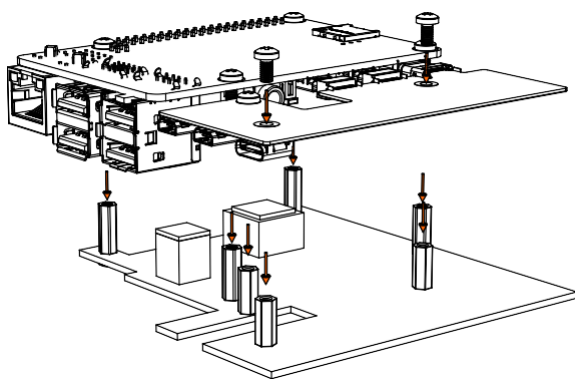

4.

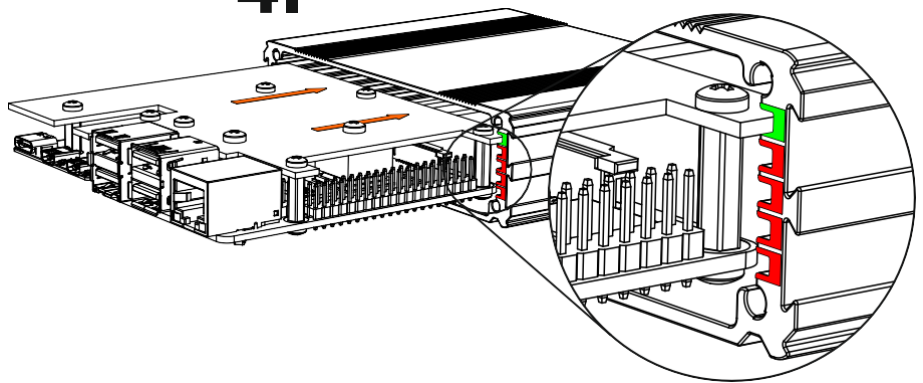

5.

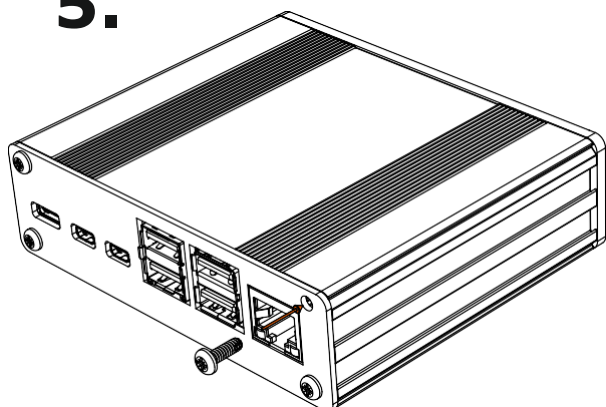

1. Take carrier plate (g) & attach standoffs (c) & (d) with screws (b). Attach small heat block (j) and large heat block (l) to carrier plate (g) with screws (n) as shown. Peel backing paper from small heat pad (k) & stick to small heat block (j). Do the same for large heat pad (m) & large heat block (l). Now remove remaining backing paper.
2. Plug extender board (f) into the HDMI & USB connectors on the Raspberry Pi board.
3. Place Raspberry Pi & extender on carrier plate assembly & secure with screws (b) as shown.
4. Turn board assembly over so carrier plate is on top & slide into top slot of extrusion (h) as shown.
5. Attach aluminium (e) & acrylic (i) end plates to extrusion (h) with screws (a).