

07S

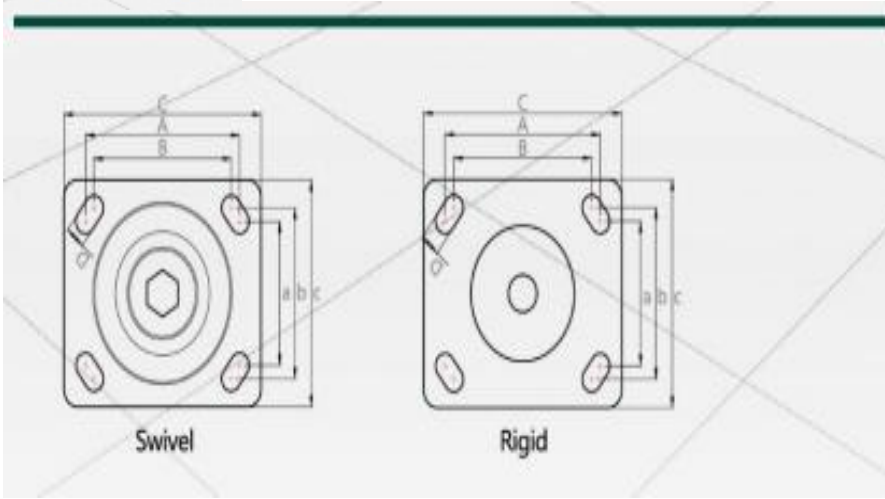

Standard	Result	
T/ZSJL 001-2019	✓	Wheel: Thermoplastic polyurethane (PU).
T/ZSJL 002-2019	✓	Wheel surface hardness: 98-100° Shore A.
T/ZSJL 003-2019	✓	Wheel core structure: cast iron.
		Bearing: SUPO customization double ball bearing.

* Remark: Please refer to the standard of Zhongshan caster industry association.

Swivel Top Plate	Wheel Material	NO.	Wheel Dia (mm)	Tread Width (mm)	Load Capacity (kg)	Load Height (mm)	Swivel Radius (mm)	Brake Swivel Radius (mm)	Bearing	Plate size (mm)	Hole Spacing (mm)	Hole size (mm)
	(PU)	J07S-01-100-282	100 (4")	50	290	143	87	139	Double Ball bearing	(C) 115 x 100	(A)92x67 (B)76x76	D(11)
		J07S-01D-100-282										
		J07S-04-100-282										
		J07S-01-125-282	125 (5")		385	164	104	149				
		J07S-01D-125-282										
		J07S-04-125-282										
		J07S-01-150-282	150 (6")		440	190	121	150				
		J07S-01D-150-282										
		J07S-04-150-282										
		J07S-01-200-282	200 (8")		505	240	158	172				
		J07S-01D-200-282										
		J07S-04-200-282										