



ENGLISH

Datasheet

RS Pro Electronic Tyre Tread Depth Gauge

RS Stock No: 180-9464



Specifications:

Lightweight robust construction
Carbon Fibre Composite: Gauge Body and Probe
Range: 0 – 25mm / 1"
Resolution: 0.01mm / 0.0005"
Accuracy: $\pm 0.2\text{mm}$
3 Button operation:
On / Off
Inch / Metric
Zero Set
Power: 1 x 3V Lithium battery CR2032
Auto power off after 4 minutes

Order Code	Manufacturers Code	Description
180-9464	49-850-025	Electronic Tyre Tread Depth Gauge



ENGLISH

Datasheet

RS Pro Electronic Tyre Tread Depth Gauge

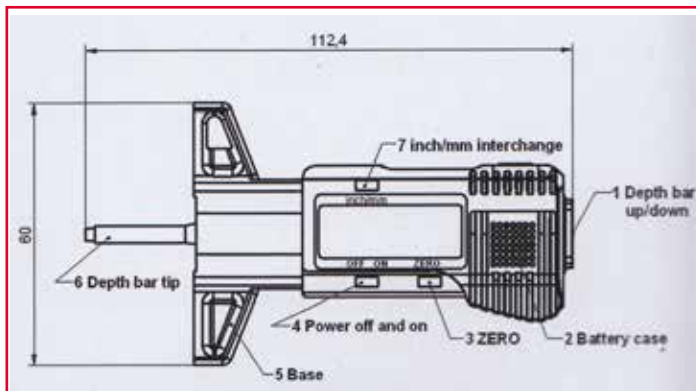

Instructions:

Insert battery + pole upward (2)

Switch gauge on (4)

Sit base (5) onto a flat surface and press bar (1) down to contact probe tip (6) onto a flat surface

Set zero (3)

Sit base (5) onto tyre surface and push depth probe into tyre tread.

When the base is located firmly on the tyre surface and the depth probe is touching the bottom of the tread, the tread depth can be read directly from the digital display

Switch instrument off after use

The instrument will automatically switch off after 4 minutes of non use

Instrument Care:

Always clean the instrument after use using a soft dry cloth or paper

Do not get water or oil on the depth bar (1)

Remove the battery if instrument is not to be used for a long period

The display will flash to indicate the battery is low

If the display does not work correctly, remove the battery for 30 seconds and replace.

Working temperature: 0 - 40°C