

XVGB2S

Monolithic tower lights, Harmony XVG, 60mm, red green, steady light, buzzer, aluminium tube mounting and L bracket, IP23, 24V AC/DC



Main

| | |
|------------------------------------|--|
| Range of product | Harmony XVG |
| Product or component type | Complete pre-wired monolithic tower light |
| Beacon or indicator bank unit type | 2 illuminated units |
| Material | PC (UL94 V-2): globe ABS (UL94HB): tube body Aluminium: tube |
| Mounting diameter | 60 mm |
| Component name | XVG |
| Device mounting | Tube with L bracket |
| Light source | LED steady red LED steady amber |
| Light block color | Red/green |
| Indicator bank base type | Base with integrated buzzer |

Complementary

| | |
|--|----------------------|
| Rated supply voltage | 24 V AC/DC |
| Cable cross section | 0.33 mm ² |
| Discrete output type | PNP and NPN |
| [Uimp] rated impulse withstand voltage | 0.5 kV |
| Current consumption | 140 mA |
| Noise level | 85 dB |
| Power consumption in W | 3.1 W |
| Fundamental frequency | 2.64 kHz |
| Net weight | 0.43 kg |

Environment

| | |
|---------------------------------------|---------------|
| Product certifications | CE[RETURN]EAC |
| Ambient air temperature for storage | -35...70 °C |
| Ambient air temperature for operation | -10...50 °C |
| IP degree of protection | IP23 |

Packing Units

| | |
|------------------------------|---------|
| Unit Type of Package 1 | PCE |
| Number of Units in Package 1 | 1 |
| Package 1 Height | 8.6 cm |
| Package 1 Width | 14.3 cm |
| Package 1 Length | 55.8 cm |
| Package 1 Weight | 625.0 g |
| Unit Type of Package 2 | S04 |
| Number of Units in Package 2 | 5 |
| Package 2 Height | 30 cm |
| Package 2 Width | 40 cm |

| | |
|------------------|--------|
| Package 2 Length | 60 cm |
| Package 2 Weight | 3.2 kg |

Offer Sustainability

| | |
|----------------------------|--|
| Sustainable offer status | Green Premium product |
| REACH Regulation | REACH Declaration |
| EU RoHS Directive | Pro-active compliance (Product out of EU RoHS legal scope) |
| Mercury free | Yes |
| China RoHS Regulation | China RoHS Declaration |
| RoHS exemption information | Yes |
| Environmental Disclosure | Product Environmental Profile |
| Circularity Profile | End Of Life Information |

Contractual warranty

| | |
|----------|-----------|
| Warranty | 18 months |
|----------|-----------|

Dimensions

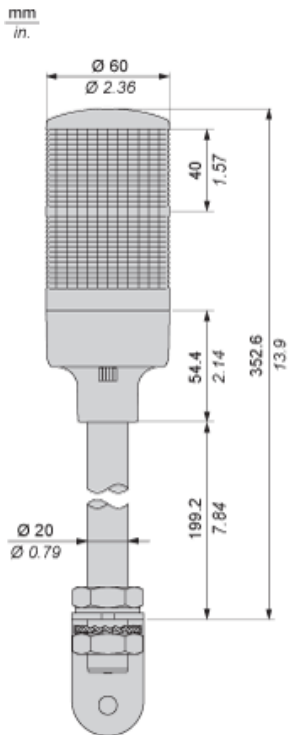

Mounting

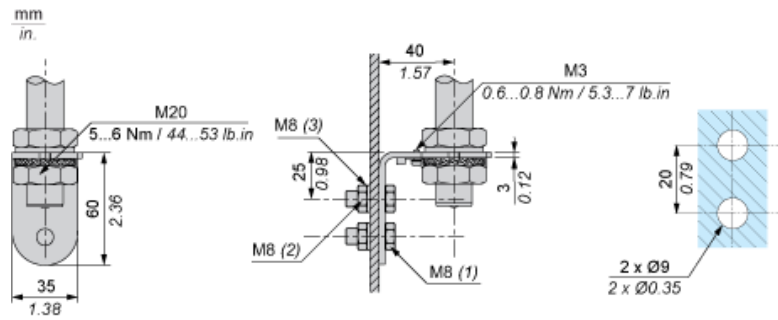

- (1) Thickness +10 mm/0.39 in
- (2) Hexagon Nut
- (3) Washer

Wiring

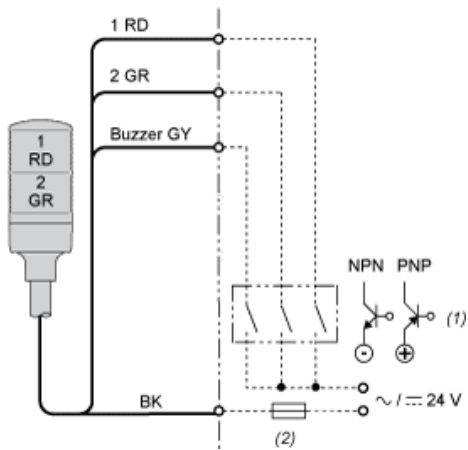

- (1) "ON" for lighting and/or applying continuous sound.
 - (2) Fuse (rated current: 0.5 A)
- RD : Red
GR : Green
GY : Grey
BK : Black