

\* = Conical form tapering downward.  
 Untoleranced dimensions per GTA 13/5 DIN 1688

OPTIONAL ACCESSORIES		
PART NAME	QTY.	AVILABILITY
MOUNTING PLATE	1	Y
EXTERNAL HINGE	2	Y
INTERNAL HINGE	2	Y
MOUNTING BRACKETS	4	Y
NEOPRENE/SILICON GASKET	1	Y
DIN RAIL TS15	-	N
DIN RAIL TS35	1	Y

LID

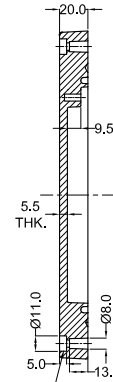
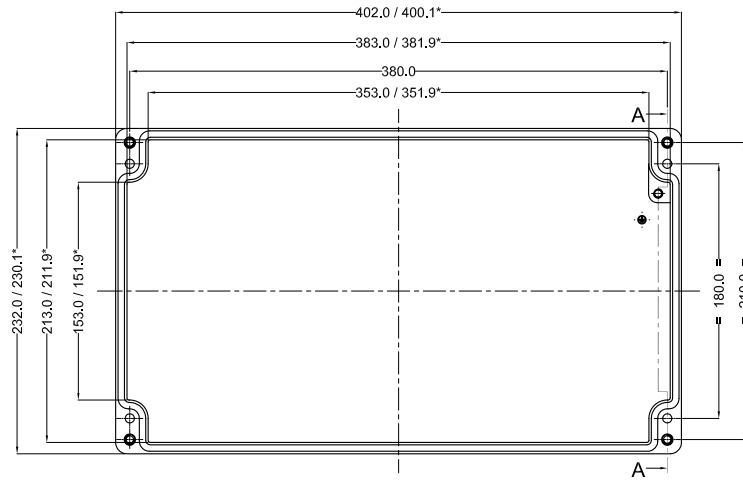

Cylinder Screw  
 M6 x 25/10 similar to DIN 84

SECTION A-A

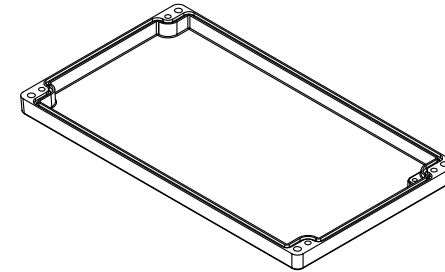

BASE

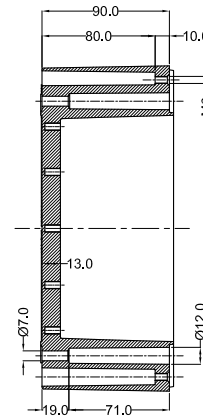
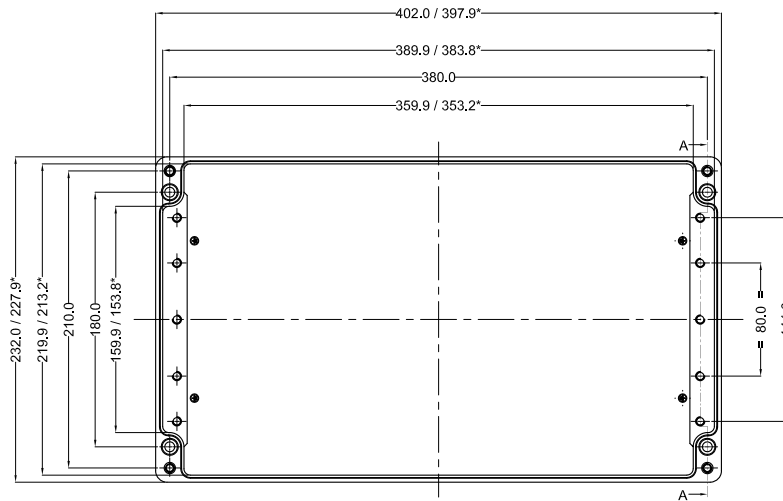

SECTION A-A

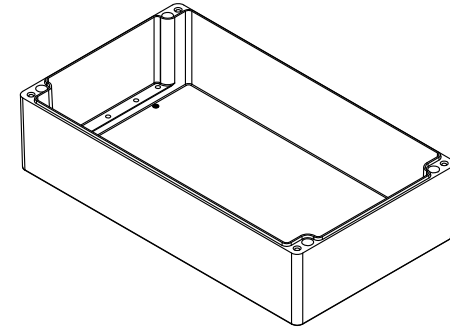

QUANTITY	MATERIAL :-	MACH.NAME	DATE	SIGN	NAME	
-	<b>Alsi12</b>	-			<b>RRPL</b>	<b>DESIGN</b>
	<b>Din230</b>		<b>12/09/14</b>		<b>MANOJ</b>	<b>DRAWN</b>
		<b>TITLE :-</b>	<b>12/09/14</b>		<b>PAVAN</b>	<b>CHECKED</b>
		JUNCTION BOX 400 x 230 x 110	<b>12/09/14</b>		<b>M. S.</b>	<b>APPROVED</b>
			<b>SCALE</b>			
<b>TOLERANCE</b>	<b>WEIGHT:</b>	<b>FINISH:</b>				
±0.2		NATURAL				
±0.2	<b>HOLES</b>		ALL DIMENSION ARE IN MM			
±1.0°	<b>ANGLES</b>		RJ - 35			