

**Seals** 



**SPRING  
BALANCER**

彈簧吊車

## SB-K系列 SB-K Series

SEALS 螺旋式彈簧吊車是一系列經濟實惠符合人體工學的工具懸吊設備，使作業人員工作更輕鬆、更安全、更有效率。另外，同時使工作場合更加整齊並保護工具免於碰撞及掉落。

In the design, the "SEALS Spiral Spring Balancer" is a cost-efficient tool suspending equipment meeting the ergonomic requirement which allows the operator to perform the work in an easier, safer and more efficient way. In addition, it maintains the working site orderly and prevents the tool from colliding and falling.

### 優點

#### Advantages

##### 省力化

採螺旋式設計，螺徑由小到大，與彈簧由弱轉強的拉力相衡下，平衡輸出拉力，從而提供一致的吊力，讓使用者毫不費力的作業。使工具可停留在任何高度並保持靜止狀況，並使使用者在不付擔任何工具重量下作業。避免長期拿取工具重物作業，所產生肌肉緊繃及疲勞。

Labor Saving: It is designed in spiral type by arranging small-to-big spiral diameters. With the checking force of weak-to-strong spring tension, it outputs the tension in a balanced manner to provide consistent suspension force that allows the operator to carry out the operation without burden. Further, it also lets the tool pause at any height and maintains at still status. In this way, the user can perform the operation without sustaining any tool load; thus, avoiding tense muscle and fatigue resulting from long-term holding of tools and heavy objects.

##### 有生產力

使用者可輕易地將工具拉到哪口停到哪口，停在容易取用工具的地方，讓工作更加順暢及有效率。

Productive: The user can easily drag the tool to where he wants and stop at easier access position to achieve smoother and more efficient operation.

##### 有效率的

讓工具可時時上手，不用因同時要取用工作物品，而將工具放下再取用，所產生的時間浪費及力氣消耗。

Efficient: The operator can handle the tool easily; thus, avoiding wasting time and consuming labor by lowering the tool and picking it again when taking the object at the same time.

##### 經濟性

堅固的機構設計使產品更加耐用，讓維護成本更為低廉。並且使懸吊工具因碰撞及掉落而造成損失的機率大為降低。

Cost-efficient: Rigid mechanism design makes the product more durable while bringing down the maintenance cost. In this way, it can significantly minimize the loss probability due to the colliding and falling of the suspended tool.

### 特色

#### Features

- 1 提供0.5公斤到30公斤吊重，共七種不同吊重範圍可供選用。  
It provides 0.5kg to 30kg of lifting load, and a number of 7 different load ranges are provided for option.
- 2 安裝吊勾可360度旋轉。  
When mounted with Install Hook, it can perform 360-degree revolving.
- 3 鋁重力壓鑄外殼。  
Aluminum die casting housing.
- 4 配備防墜鋼索安裝孔。(務必安裝，以避免原安裝處失效)  
It is provided with anti-falling steel wire installation hole (it must be installed to avoid the failure of the original mounting location).
- 5 快速安裝。  
Fast in installation.
- 6 封閉式吊勾。  
Enclosed type of Lifting Hook and Install Hook.
- 7 彈簧斷裂時，工具防墜裝置。(限SB-15K, SB-22K, SB-30K)  
Tool anti-falling device is provided in case of the spring breaking (only for SB-15K, SB-22K, SB-30K).
- 8 耐用性彈簧。  
Durable spring.

## SB-K系列 / SB-K Series



SB-1.5K

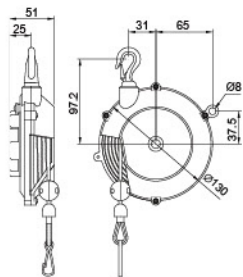

SB-3K/5K  
SB-7K(S)

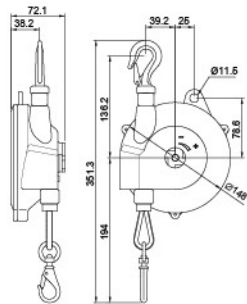

SB-9K/15K

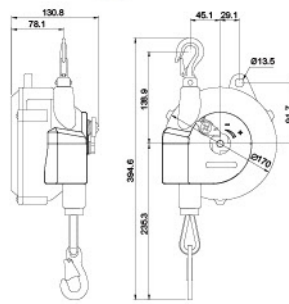

SB-22K/30K

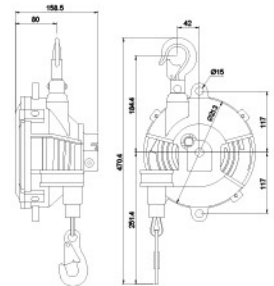

型號 Model	荷重 Capacity (kg)	淨重 Weight (kg)	揚長 Travel (m)	繩索 Rope option(mm)	繩索線徑 Rope Dia(mm)	數量 Q'ty (Ctn.)	毛重 G.W./Ctn (kg)	材積 Cuft (Ctn.)
SB-1.5K	0.5-1.5	0.73	1.3	Cable	2	20	15.6	1.9
SB-3K	1.5-3.0	1.73	1.3	Cable	3.2	10	18.3	1.7
SB-5K	3.0-5.0	1.82	1.3	Cable	3.2	10	19.2	1.7
SB-7K(S)	5.0-7.0	1.85	1.3	Cable	3.2	10	19.5	1.7
SB-9K	5.0-9.0	3.59	1.3	Cable	4.0	4	15.36	1.9
SB-15K	9.0-15.0	3.61	1.3	Cable	4.0	4	15.44	1.9
SB-22K	15.0-22.0	7.7	1.5	Cable	4.8	3	24	2.5
SB-30K	22.0-30.0	8.3	1.5	Cable	4.8	3	26	2.5

# SB-K 系列 SB-K Series

## SEALS

"SEALS" Spiral Spring Balancer is a cost-efficient tool suspending equipment meeting the ergonomic requirement which allows the operator to perform the work in an easier, safer and more efficient way.

### 特色 Features

- Labour Saving:**  
 The spiral type outputs the consistent suspension force.
- Productive:**  
 The users can easily drag the tool to where they want and stop at easier access position to achieve smoother and more efficient operation
- Efficient:**  
 The operator can handle the tool easily; thus, avoiding wasting time and consuming labor in putting and picking tools when taking the object the same time.
- Cost-Efficient:**  
 Rigid mechanism design makes the product more durable while bringing down the maintenance cost.
- Anti-Falling:**  
 Device will lock the cable in case of spring breakage.

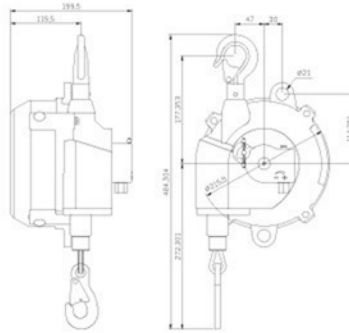

SB-60K / SB-70K

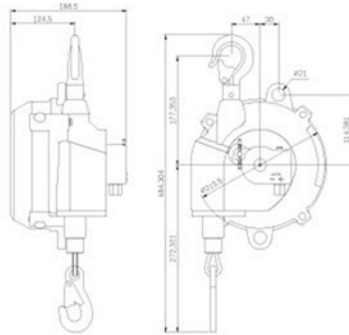

SB-40K / SB-50K



Tension Indicator



Tension Adjust by Worm Gear

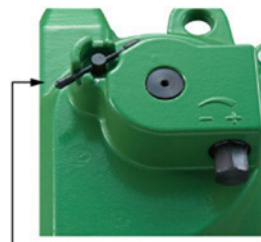

Lock Spring Drum Position  
鎖住螺旋座位置

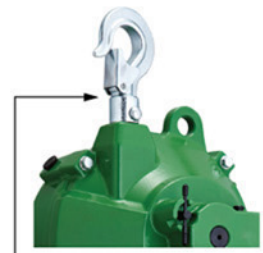

360° Swivel Hanger

型號 Model	荷重 Capacity	淨重 Weight	揚長 Travel	繩索 Rope option	鋼索線徑 Rope Dia	數量 Q'ty(C'tn)	毛重 G.W./Ctn	材積 Cuft(C'tn)
SB-40K	30-40 kg	9.7 kg	1.5 m	Cable	4.8 mm	1 piece	11 kg	0.9
SB-50K	40-50 kg	10.1 kg	1.5 m	Cable	4.8 mm	1 piece	11.4 kg	0.9
SB-60K	50-60 kg	11.1 kg	1.5 m	Cable	4.8 mm	1 piece	12.4 kg	0.9
SB-70K	60-70 kg	11.4 kg	1.5 m	Cable	4.8 mm	1 piece	12.7 kg	0.9

# THB 系列 THB Series

www.chengmao.com.tw

## 特色 Features

- Adopting 8mm inner diameter PU braided hose to provide enough air flow to air tool and equipment.
- It achieves neat and orderly production line for enhancing the working efficiency.
- Tool anti-falling device is provided in case of spring breaking.
- The installation is fast and convenient with 360 degrees install hanger.
- Worm gear provides more precise force adjustment.

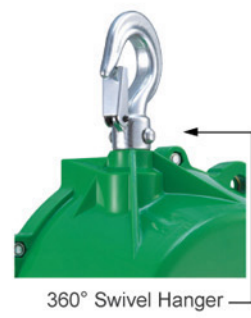
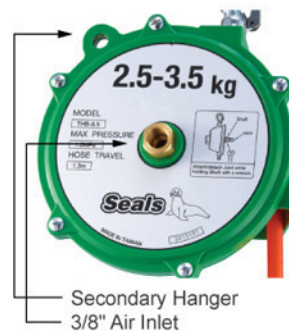
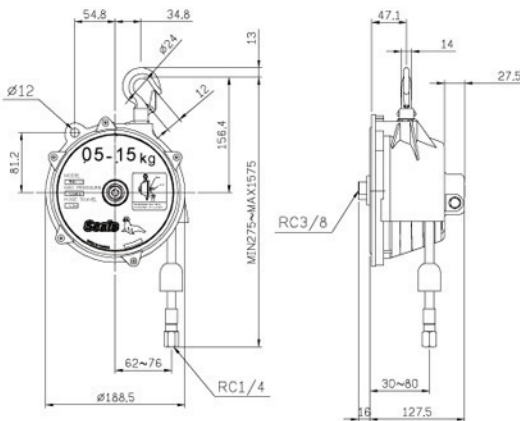

型號 Model	荷重 Capacity	淨重 Weight	揚長 Travel	風管材質 Hose Material	風管線徑 Hose Dia	數量 Q'ty(C'tn)	毛重 G.W./Ctn	材積 Cuft(C'tn)
THB-1.5	0.5-1.5 kg	2.2 kg	1.3 m	PU Braided	8*12mm	6 pcs	14.8 kg	2.5
THB-2.5	1.5-2.5 kg	2.3 kg	1.3 m	PU Braided	8*12mm	6 pcs	15.4 kg	2.5
THB-3.5	2.5-3.5 kg	2.4 kg	1.3 m	PU Braided	8*12mm	6 pcs	16 kg	2.5
THB-5.0	3.5-5.0 kg	2.4 kg	1.3 m	PU Braided	8*12mm	6 pcs	16 kg	2.5
THB-6.5	5.0-6.5 kg	2.5 kg	1.3 m	PU Braided	8*12mm	6 pcs	16.6 kg	2.5



以茂企業有限公司

經銷商 Distributor



合豐機械(新)私人有限公司  
HUP HONG MACHINERY (S) PTE LTD

101 Kitchener Road, #01-12/14 Jalan Besar Plaza, Singapore 208511

Tel: (65) 6296-7711 Fax: (65) 6297-1963 & 6297-0139

Email: sales@huphong.com.sg Website: www.huphong.com.sg

Estd.1972