

Every part matters



User Manual V1.2 2017

236-9298

45A DIRECT CONNECT

- Measures kWh, kVarh, kW, kVar, kVA, PF, Hz, dmd, V, A, etc.
- Bi-directional measurement IMP & EXP
- Two pulse outputs
- RS485 Modbus RTU / Mbus
- Din rail mounting 18mm
- 45A direct connect
- Better than Class 1 accuracy

1. Introduction

This document provides operating, maintenance and installation instructions of 236-9298. The unit measures and displays the characteristics of single phase two wires application. It provides voltage, current, power, frequency, power factor and energy information.

The direct connect type can work with direct load 45A.

Two Pulse outputs and 1 remote communication port are provided.

Model	Current Input	Communication	MID
236-9298	Direct connect 45A	RS485 Modbus	●

2. Specifications

2.1 General Specifications

Voltage AC (Un) 230V
 Voltage Range 176~276V AC
 Current Input 0.25~5(45)A (SDM120 45A)

Power consumption <2W/10VA
 Frequency 50/60Hz (50Hz only for MID version)
 AC voltage withstand 4KV for 1 minute
 Impulse voltage withstand 6KV-1.2uS wavform
 Overcurrent withstand 30I_{max} for 0.01s (SDM120 45A)
 Pulse output rate 1000imp/kWh (default)
 1000/100/10/1 imp/kWh/kVarh (configurable)

Display
 Max. Reading

LCD with white backlight
 99999.9kWh

2.2 Accuracy

Voltage 0.5% of range maximum
 Current 0.5% of nominal
 Frequency 0.2% of mid-frequency
 Power factor 1% of Unity
 Active power 1% of range maximum
 Reactive power 1% of range maximum
 Apparent power 1% of range maximum
 Active energy Class 1 IEC62053-21
 Class B EN50470-3 (MID)
 Reactive energy 1% of range maximum

2.3 Environment

Operating temperature -25° to +55°
 Storage and transportation temperature -40° to +70°
 Reference temperature 23° ±2°
 Relative humidity 0 to 95%, non-condensing
 Altitude up to 2000m
 Warm up time 3s
 Mechanical environment M1
 Electromagnetic environment E2
 Degree of pollution 2

2.4 Mechanics

Din rail dimensions 18x119x62 (WxHxD) DIN 43880
 Mounting DIN rail 35mm
 Sealing IP51 (indoor)
 Material self-extinguishingUL94V-0

3 Display

Initialization Display

When it is powered on, the meter will initialize and do self-checking.

1		Full screen It will last for 3 seconds.
2		Software version It will last for 3 seconds.
3		Total active energy(kWh)

After the self-checking program, the meter screen will display the total active energy (kWh)

Scroll Display by button

There is a button on the front of the meter. After initialization and self-checking program, the meter display the measured values. The default page is total kWh. If the user wants to check other information, he needs to press the scroll button on the front panel.

	Click the button, the LCD display will scroll the measurements.
	Keep pressing the button for 3 seconds, the meter will enter set-up mode.

1		Total active energy(kWh) Display format:0000.00 9999.99 10000.0 99999.9 0000.00
1-1		Import active energy(kWh) Display format:0000.00 9999.99 10000.0 99999.9 0000.00
1-2		Export active energy(kWh) Display format:0000.00 9999.99 10000.0 99999.9 0000.00
2		Voltage (V)
3		Current (A)
4		Active power (W)
5		Frequency (F)
6		Power factor (PF)
7		Modbus Address or Primary address Default: 001
8		Baudrate Default : 2400bps
9		Parity None/Even/Odd are optional Default: none
10		Software version In kind prevail

The display of each model:

236-9298 : Total kWh → Import kWh → Export kWh → Voltage →
 Current → Active power → Frequency → Power factor → Address
 → Baudrate → Parity → Software version

4. Communication

4.1 Pulse Output

The meter is equipped with 2 pulse outputs, which are fully isolated from the inside circuit. That generates pulses in proportion to the measured energy. The pulse outputs are polarity dependent, passive transistor output requiring an external voltage source for correct operation. For this external voltage source, the voltage shall be 5-27V DC, and the maximum input current shall be 27mA DC.

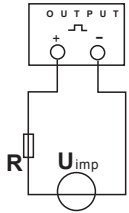

ATTENTION: Pulse output must be fed as shown in the wiring diagram below. Respect polarities and the connection mode. Opto-coupler with potential-free SPST-NO Contact.

Contact range: 5~27VDC Max. current
Input: 27mA DC

4.2 Pulse Output 1

Pulse output 1 is configurable. The pulse output 1 can be set to generate pulses to represent total / import/ export kWh or kVarh. The pulse constant can be set to generate 1 pulse per: 0.001 (default) / 0.01 / 0.1 / 1kWh / kVarh.
Pulse width: 200 / 100/ 60ms (default)

4.3 Pulse Output2

Pulse output 2 is non-configurable. It is fixed up with Import kWh. The constant is 1000imp/kWh.
The Pulse width: 60ms

4.4 RS485 output for Modbus RTU

The meter provides a RS485 port for remote communication. Modbus RTU is the protocol applied. For Modbus RTU, the following RS485 communication parameters can be configured from the Set-up menu.
Baud rate: 1200, 2400, 4800, 9600
Parity: NONE/EVEN/ODD
Stop bits: 1 or 2
Modbus Address: 1 to 247

5. Dimensions

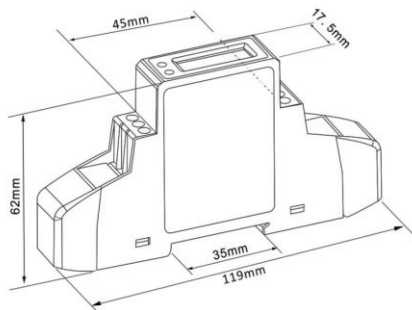

6. Installation

6.1 Safety instruction

Information for your own safety

This manual does not contain all of the safety measures for operation of the equipment (module, device), because special operating conditions, and local code requirements or regulations may necessitate further measures. However, it does contain information which must be read for your personal safety and to avoid material damages. This information is highlighted by a warning triangle and is represented as follows, depending on the degree of potential danger.



Warning
This means that failure to observe the instruction can result in death, serious injury or considerable material damage.



Caution
This means hazard of electric shock and failure to take the necessary safety precautions will result in death, serious injury or considerable material damage.

Qualified personnel

Operation of the equipment (module, device) described in this manual may only be performed by qualified personnel. Qualified personnel in this manual means person who are authorized to commission, start up, ground and label devices, systems and circuits according to safety and Regulatory standards.

Proper handling

The equipment (device, module) may only be used for the application specified in the catalogue and the user manual.

- ◆ Use only insulating tools.
- ◆ Do not connect while circuit is live (hot).
- ◆ Place the meter only in dry surroundings.
- ◆ Do not mount the meter in an explosive area or expose the meter to dust, mildew and insects.
- ◆ Make sure the used wires are suitable for the maximum current of this meter.
- ◆ Make sure the AC wires are connected correctly before activating the current/voltage to the meter.
- ◆ Do not connect the meter to a 3 phase - 400VAC - network.
- ◆ Do not touch the meter connecting clamps directly with your bare hands, with metal, blank wire or other material as you may get an electrical shock.
- ◆ Make sure the protection cover is placed after installation.
- ◆ Installation, maintenance and reparation should only be done by qualified personnel.
- ◆ Never break the seals and open the front cover as this might influence the functionality of the meter, and will avoid any warranty.
- ◆ Do not drop, or allow physical impact to the meter as there are high precision components inside that may break.

6.2 Installation

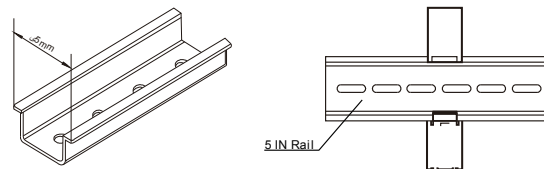

6.3 Wiring diagram

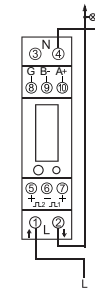

236-9298

7. Declaration of Conformity (for the MID approved version meter only)

Single phase multifunction electrical energy meter "236-9298", corresponds to the production model described in the EC-type examination certificate and to the requirements of the Directive 2004/22/EC EC type examination certificate number 0120/SGS0585. Identification number of the NB 0120.

Meaning of Symbols



EU conformity mark



UK conformity mark



Measuring Instruments Directive (MID 2014/32/EU).

FOR MORE INFORMATION VISIT THIS SITE

<http://www.rs-components.com/index.html>

UK – Birchington Rd, Corby NN17 9RS
EU - Mainzer Landstraße 180. 60327 Frankfurt/Main

The Information contained in these installation instructions is for use only by installers trained to make electrical power installations and is intended to describe the correct method of installation for this product. However, Company has no control over the field conditions which influence product installation.

It is the user's responsibility to determine the suitability of the installation method in the user's field conditions. Company only obligations are those in Company standard Conditions of Sale for this product and in no case will Company be liable for any other incidental, indirect or consequential damages arising from the use or misuse of the products.

FOR MORE INFORMATION VISIT THIS SITE

<http://www.rs-components.com/index.html>

