

XB5KS2B4

Annunciator, Harmony XB5, Illuminated buzzer, plastic, red, 22mm, continuous or intermittent tone, 24V AC DC



Main

Range of product	Harmony XB5
Product or component type	Annunciator
Bezel material	Plastic
Mounting diameter	22 mm
Cap/operator or lens colour	Red

Complementary

Supply circuit type	AC/DC
Supply frequency	50/60 Hz
Signalling type	Continuous or intermittent tone
Noise level	90 dB 6.8 kHz 0.1 m +/- 10 %
Resistance to high pressure washer	9000000 Pa at 80 °C, distance : 0.1 m
Height	29 mm
Width	29 mm
Depth	55 mm
Net weight	0.024 kg
Current consumption	<= 58 mA
[Us] rated supply voltage	24 V +/- 10 %

Environment

Protective treatment	TH
Ambient air temperature for storage	-40...70 °C
Ambient air temperature for operation	-40...70 °C
Overvoltage category	Class II conforming to IEC 60536
NEMA degree of protection	NEMA 4X NEMA 13
Standards	CSA C22.2 No 14 IEC 60947-5-1 IEC 60947-5-4 JIS C8201-5-1 IEC 60947-1 UL 508 IEC 60947-5-4 IEC 60947-5-1 IEC 60947-1 JIS C8201-1 IEC 60529 IEC 62262 IEC 50102
Product certifications	UL listed[RETURN]CSA[RETURN]BV

The information provided in this documentation contains general descriptions and/or technical characteristics of the performance of the products contained herein. This documentation is not intended as a substitute for and is not to be used for determining suitability or reliability of these products for specific user applications. It is the duty of any such user or integrator to perform the appropriate and complete risk analysis, evaluation and testing of the products with respect to the relevant specific application or use thereof. Neither Schneider Electric Industries SAS nor any of its affiliates or subsidiaries shall be responsible or liable for misuse of the information contained herein.

Packing Units

Unit Type of Package 1	PCE
Number of Units in Package 1	1
Package 1 Height	3.3 cm
Package 1 Width	3.4 cm
Package 1 Length	6 cm
Package 1 Weight	27 g
Unit Type of Package 2	S01
Number of Units in Package 2	88
Package 2 Height	15 cm
Package 2 Width	15 cm
Package 2 Length	40 cm
Package 2 Weight	2.629 kg
Unit Type of Package 3	P06
Number of Units in Package 3	1408
Package 3 Height	70 cm
Package 3 Width	80 cm
Package 3 Length	60 cm
Package 3 Weight	43.016 kg

Offer Sustainability

Sustainable offer status	Green Premium product
REACH Regulation	REACH Declaration
EU RoHS Directive	Pro-active compliance (Product out of EU RoHS legal scope)
Mercury free	Yes
China RoHS Regulation	China RoHS Declaration
RoHS exemption information	Yes
Environmental Disclosure	Product Environmental Profile
Circularity Profile	No need of specific recycling operations
WEEE	The product must be disposed on European Union markets following specific waste collection and never end up in rubbish bins

Dimensions

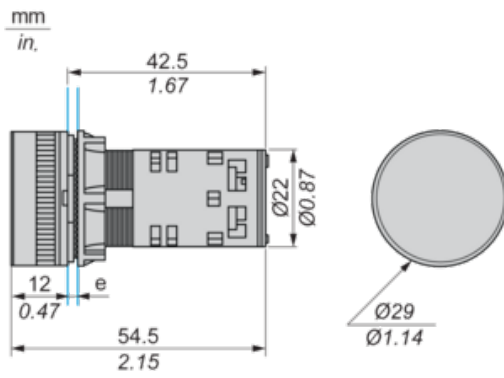

e: Clamping thickness: 1 to 6 mm / 0.04 to 0.24 in.

Panel Cut-out for Buzzer

Connection by Screw Clamp Terminals

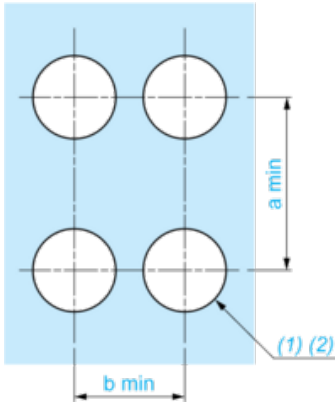

(1) Diameter on finished panel or support

(2) $\text{Ø}22.5 \text{ mm}$ recommended ($\text{Ø}22.3 \text{ }_0^{+0.4}$) / $\text{Ø}0.89 \text{ in.}$ recommended ($\text{Ø}0.88 \text{ in. }_0^{+0.016}$)

Connections	a in mm	a in in.	b in mm	b in in.
By screw clamp terminals or plug-in connector	40	1.57	30	1.18

Cabling of Annunciators

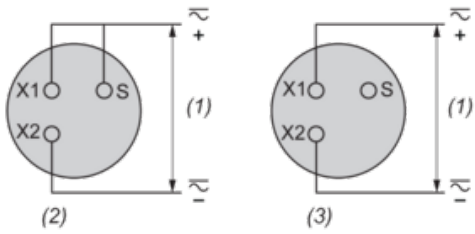

- (1) Supply
- (2) Intermittent
- (3) Continuous