

Range datasheet

RS Pro Anti-Vibration Flange Mount



Product Details -

SCM mounts are ideal for use on static applications such as small pumps, engines and light electronic equipment

. Features:

- Achieves high isolation values (both active and passive) of low frequency vibration
- Attenuates shock loads due to its deflection capacity.
- Available in stainless steel metal for food & mining industry applications

Applications:

- Fans • Pumps
- Stationary generator sets • Vibrating screens
- Bulk bin load and discharge units • Computers, security cameras
- Packaging and transit case mountings

Line Drawing -

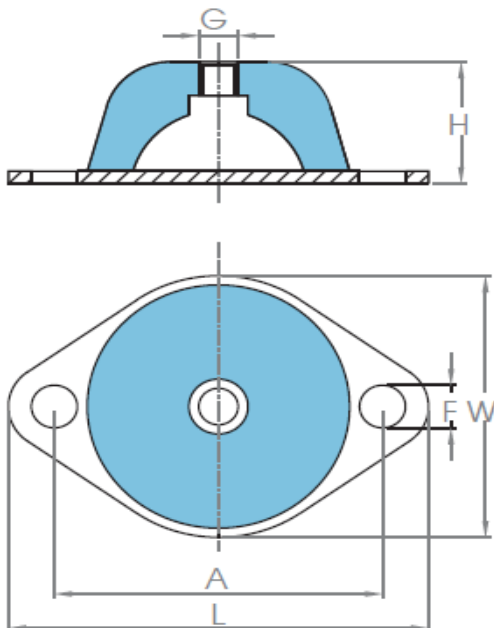



Range Table:

RS Stock number	Description	H	L	W	G	A	F	Shape
1263905	Shear/Compr. Mount 150x63 M12 60 ShA NR	63	150	150	M12	20	14.5	Square
1263578	Shear/Compr. Mount 200x85 M16 60 ShA NR	85	200	200	M16	160*160	14.5	Square

RS Stock number	Description	45ShA		60ShA	
		Max Load (kg)	Max Deflection (mm)	Max Load (kg)	Max Deflection (mm)
1263580	Shear/Compr. Mount 136x40 M10 60 ShA NR	75	8.5	140	11
1263579	Shear/Compr. Mount 151x45 M10 60 ShA NR	302	14	500	13
1263904	Shear/Compr. Mount 64x20 M6 60 ShA NR	3.5	3	9	3
1263576	Shear/Compr. Mount 85x25 M10 60 ShA NR	21	4	40	4