

Datasheet

IEC 1/2"UNF-20 Melt Bolt Thermocouple with Type 'J' Thermocouple Plug

A choice of 76mm (3") or 152mm (6") bolt lengths with 5mm immersion



- Type 'J' (Iron/Constantan) Melt Bolt Thermocouple
- Typically used in plastics extruders and injection moulders
- Designed to withstand high pressure applications experienced with molten plastics & polymers
- Stainless steel bolt with 1/2"UNF-20 thread
- Choice of 76mm or 152mm bolt lengths
- 5mm long (x 3mm diameter) immersion length
- Temperature range to 500°C
- Insulated hot junction
- Standard plug termination (round pin)
- Tolerance & colour code in accordance with IEC-584 specification

T/C Type	Thread	Bolt Length ('L')	Tip Immersion Length	Allied Code	RS order Code
J (Iron/Con)	1/2"UNF-20	76mm (3" inch)	5.0mm (3.0mm diameter)	70641639	219-4731
J (Iron/Con)	1/2"UNF-20	152mm (6" inch)	5.0mm (3.0mm diameter)	70642070	353-4578

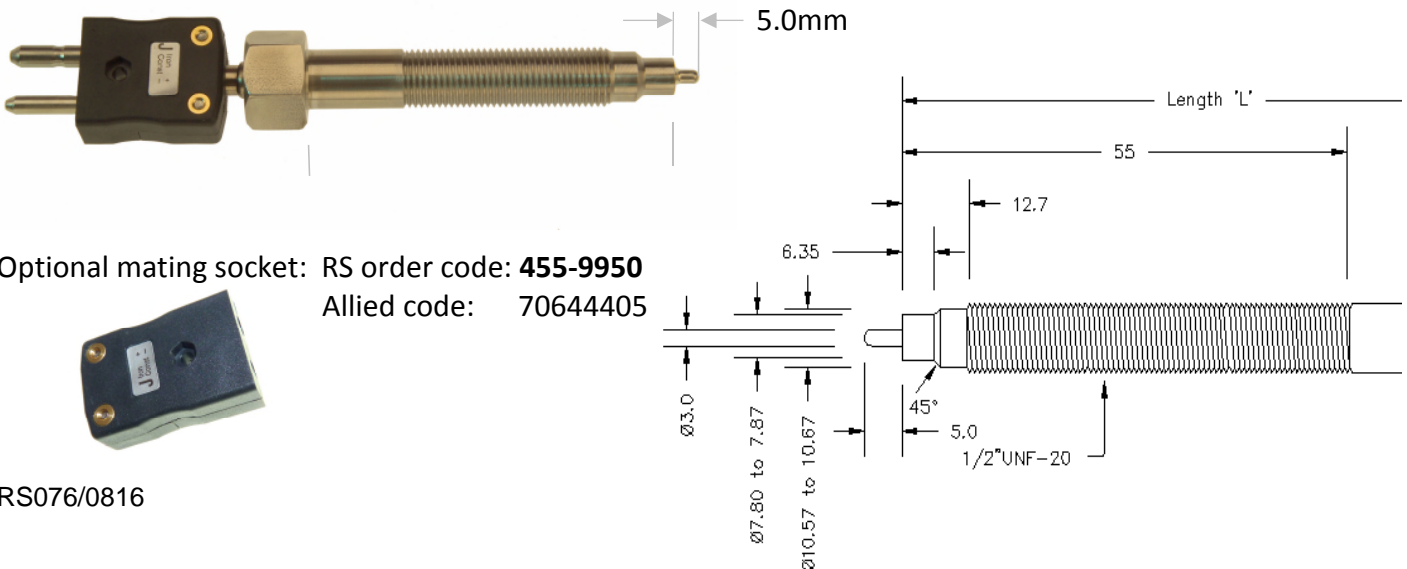

Optional mating socket: RS order code: **455-9950**
Allied code: 70644405

