

* = Conical form tapering downward.
 Untoleranced dimensions per GTA 13/5 DIN 1688

LID

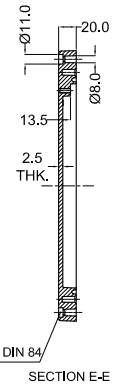

OPTIONAL ACCESSORIES		
PART NAME	QTY.	AVILABILITY
MOUNTING PLATE	1	Y
EXTERNAL HINGE	2	Y
INTERNAL HINGE	2	Y
MOUNTING BRACKETS	4	Y
NEOPRENE/SILICON GASKET	1	Y
DIN RAIL TS15	-	N
DIN RAIL TS35	1	Y

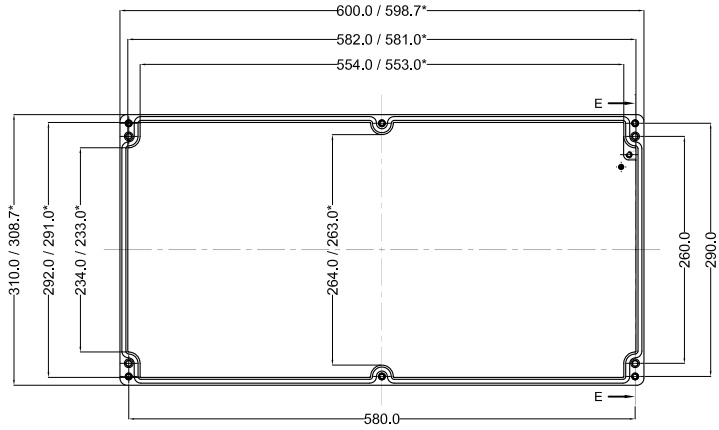
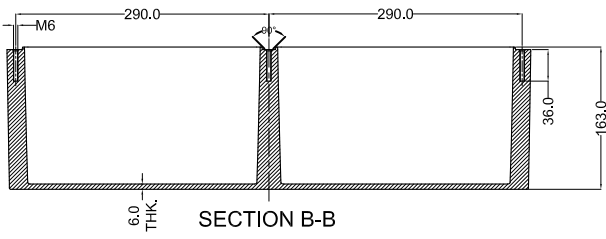
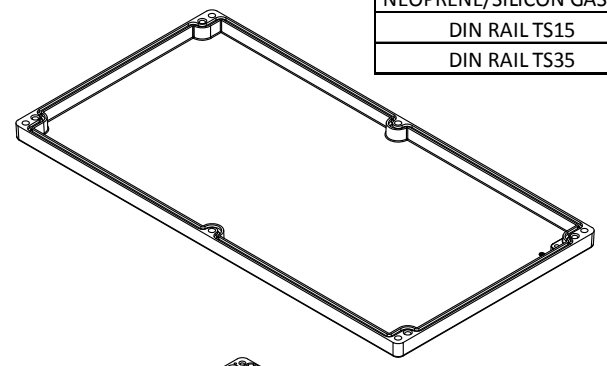

SECTION B-B

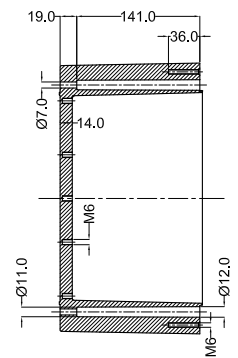
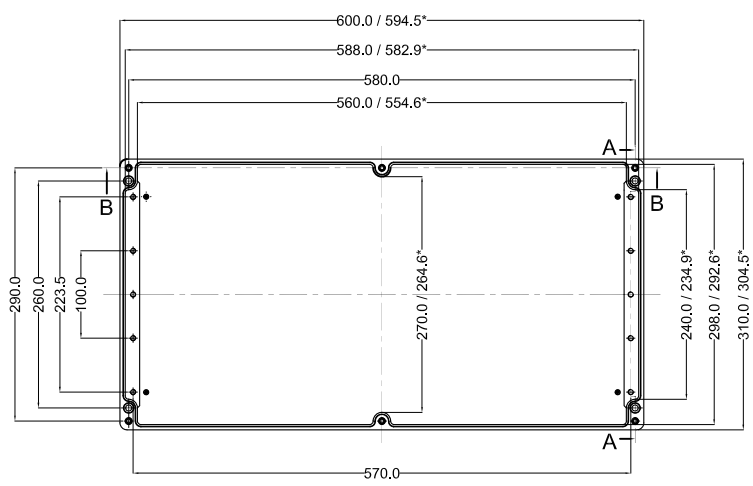
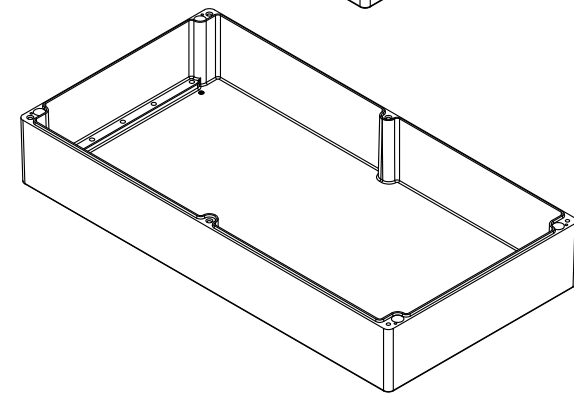

SECTION A-A

BASE



QUANTITY	MATERIAL :-	MACH.NAME	DATE	SIGN	NAME	
-	Alsi 12	-	15/01/14		RRPL DESIGN	
	Din230		15/01/14		MANOJ DRAWN	
		TITLE :-	15/01/14		PAVAN CHECKED	
		JUNCTION BOX	15/01/14		S . D . APPROVED	
		600 x 310 x 180				
TOLERANCE			SCALE			
±0.2	DIMENSIONS					
±0.2	HOLES					
±1.0°	ANGLES					
WEIGHT		FINISH				
-		NATURAL				
ALL DIMENSION ARE IN MM						
Rd - 34						