

INSTRUCTION MANUAL

PNEUMATIC ANGLE GRINDER

Please read this manual carefully before you attempt to use your tool so that you may use it properly and safely.

MYTON

Model **MAG-25B, MAGW-40, MAG-50, MAG-70**

PROFESSIONAL TOOL



MAG-25B



MAGW-40



MAG-50



MAG-70

Specifications

Model			MAG-25B	MAGW-40	MAG-50	MAG-70
Maximum Operating Pressure		MPa	0.6			
Air Consumption	(No Load)	m ³ /min	0.4	0.68	0.87	0.69
	(Full Load)	m ³ /min	–	0.82	–	1.15
Rated Speed (No load)		min ⁻¹ (r/min)	22,000	13,000	12,000	7,100
Depressed Center Grinding Wheel	Diameter	mm (inch)	58 (2.3)	100 (4)	125 (5)	180 (7)
	Hole	mm (inch)	9.6 (3/8)	16 (5/8)	22 (7/8)	22 (7/8)
Mass (Weight)		kg	0.55	1.6	2.2	3.4
Sound Pressure Level		dB (A)	81	86	84	80
Sound Power Level		dB (A)	92	97	95	91
Vibration Level	Body	m/s ²	0.3	1.0	0.9	0.8
	Handle	m/s ²	–	–	1.3	5.2
Thread Size of Air Inlet			Rc1/4	Rc3/8	Rc3/8	Rc3/8

Due to continuous product development/improvement the specifications and configurations in this document are subject to change without prior notice.



Manufactured by :
NITTO KOHKI Co., Ltd.
2-9-4, Nakaikegami, Ohta-ku,
Tokyo, 146-8555, Japan
TEL : (81)-3-3755-1111
FAX : (81)-3-3753-8791
E-mail : overseas@nitto-kohki.co.jp
URL : www.nitto-kohki.co.jp

Keep the manual handy – so you can use it whenever necessary.

Original Instructions

Thank you very much for your purchase of this **Nitto Kohki products**.





Before using your machine, please read this manual carefully so that you may use it properly to get the most out of it.

Please keep the manual handy - so you can use it whenever necessary.



- **English** : Please ask your dealer or distributor for instruction manual in local language(s).
- **German** : Bitte fragen Sie Ihren Händler nach eine Betriebsanleitung in Landessprache.
- **French** : S'il vous plait, veuillez demandez á votre fournisseur de manuel instruction en langue locale.
- **Spanish** : Por favor, contacte con su distribuidor para el manual de instrucciones en español.
- **Portuguese** : Por favor pessa ao seo agente ou distribuidor o manual de instrucces ih linguagen local.
- **Italian** : Per Manuale Istruzioni in lingua locale Vi preghiamo di rivolgervi al rivenditore o distributore.
- **Dutch** : Vraag uw handelaar om een nederladstalige gebruiksaanwijzing.
- **Swedish** : Be er lokala Åtreförsäljare eller distributör om manualer pá svenska.
- **Danish** : Venligst henvend Dem til den danske distributør for instructions manualer.
- **Polish** : Prosze pytac swojego dealera lub dystrybutora o instrukcje obslugi w jezyku localnym.
- **中文** : 請向當地供應商或經銷商詢問中文使用說明書

CONTENTS	page
IMPORTANT SAFETY INSTRUCTIONS	2
GENERAL: TOOLS	2
GENERAL: PNEUMATIC TOOLS	3
INSTRUCTIONS FOR THIS TOOL	4
1. USAGE	4
2. CHECK THE CONTENTS OF THE PACKAGE	4
3. AIR SUPPLY	5
4. PREPARATION (MAG-50)	5
5. GRINDING WHEELS	6
6. MOUNTING AND REMOVING GRINDING WHEEL ...	6
7. HOW TO OPERATE THE TOOL	7
8. STORAGE	8
9. ORDERING SERVICE PARTS	8
10. OPTIONAL PARTS (MAGW-40)	8
11. EXPLODED DIAGRAM: MAG-25B	9
12. EXPLODED DIAGRAM: MAGW-40	10
13. EXPLODED DIAGRAM: MAG-50	11
14. EXPLODED DIAGRAM: MAG-70	12

PICTOGRAM

-  Warning: It might be dangerous to operate the tool if the instructions supplied are not followed.
-  Using this tool improperly could result in serious injury. Read the instruction manual before use.
-  Always wear suitable eye protection.
-  Always wear suitable hearing protection.
-  Always wear respiratory protective equipment (PPE).

The following Safety notations are used throughout the manual to highlight safety precautions for the user and for the machine.

	WARNING:	Indicates a potentially hazardous situation which, if not avoided by following the instructions given, could result in death or serious injury.
	CAUTION:	Indicates a potentially hazardous situation which, if not avoided by following the instructions given, could result in injury or material damage.

Please note, however, that failure to observe safety precautions under the “**CAUTION**” category could result in a serious occurrence depending on the situation: please observe all safety precautions in the manual.

Caution: Important precautions for machine or tool setup, operation and maintenance.

IMPORTANT SAFETY INSTRUCTIONS

When using the machine, please observe the safety precautions below to prevent possible accident or injury.

GENERAL: TOOLS

WARNING

TO OPERATORS

- **Wear proper clothing for the type of work being done.**

Take care so that clothing, ties, hair, etc. will not become entangled with the moving parts. If items become entangled it will cause the operator to be pulled towards the tool and lead to possible cause of accident or injury.

- **Always wear safety glasses.**

Remember, regular glasses are not safety glasses. The lenses are only shock resistant, which will not give you sufficient eye protection you may need in your working environment.

- **Wear respiratory protective equipment (PPE).**

Wear respiratory protective equipment (PPE) when working in an environment where dust particles are generated in operation.

- **Avoid working posture that is too stressful.**

Always ensure a firm footing and well balanced posture.

- **Do not operate the tool if you are too tired.**

- **Never touch any moving parts of the tool when running.**

ABOUT WORK AREA

- **Keep the work area clean.**

Cluttered work areas (e.g. workbench) invite accidents.

- **Carefully select the work area.**

Do not expose tool to rain.

Do not use tool in a wet or soaked area.

See that the work area is adequately illuminated.

- **Never work near inflammable liquid or in a potentially explosive atmosphere.**

- **Keep children away from the work area.**

Keep children and unauthorized people away from the work area to avoid accident or injury.

BEFORE OPERATION

- **Inspect tool before use.**

Before using, check that screws are securely

tightened, that any protective cover or guard is securely in place, other parts are free from damage and that the tool runs as it should.

Check that moving parts are properly adjusted for positioning and tightened, that parts are free from damage and properly mounted, and that all other parts are in good condition for normal operation.

Should you find any damage to the protective cover or other part, replace it in accordance with the Operation Manual. If there are no instructions in the Manual, please contact the sales agent through which you have purchased your tool or an authorized dealer near you for repair.

Likewise, if a switch failure occurs, contact sales agent through which you have purchased your tool or an authorized dealer near you for repair.

Do not use the tool if it does not start or stop with the start/stop switch.

- **Securely mount cutter**

An improperly mounted cutter may fly out, causing possible damage to the machine or injury to the operator.

- **Always remove spanner, wrench, etc., once adjustment has been made with them.**

- **Use a tool appropriate for the application.**

Avoid heavy-duty application that is beyond the capacity of tool.

- **Do not use the tool for purposes other than what it is designed for.**

- **Do not abuse tool.**

Use tool in accordance with the specifications: you'll get the most out of it while ensuring safety.

- **Securely fasten workpiece in place.**

Use a vice or clamp to securely fasten the workpiece in place. It is much safer this way than holding it in your hand, allowing you to operate the tool with both hands.

ABOUT HANDLING

- **How to store tool.**

When the tool is not used, store it in a dry area and out of reach of children.

- **How to carry tool.**

Do not touch the start switch while the tool is being carried.

- **Do not leave the tool unattended while it is running.**

Turn off the start switch and disconnect the tool from power source. Do not leave the work area until the tool comes to a complete stop.

MAINTENANCE/SERVICE

- **Do not take apart or modify tool.**

Disassembly or modification carried out without the supervision of a qualified or authorized service engineer could result in an accident or injury.

- **Inspect cutting tool and accessories, etc.**

Always check to see that cutting tool and accessories, etc. are in good operating condition without damage or deterioration before you mount them on the power tool. Should you find any damage to an accessory or part, please contact sales agent through which you have purchased your tool or an authorized dealer near you for repair.

- **Check parts for damage.**

When you have found damage to accessory or other part, carefully check the damaged part to determine the extent of influence it has upon the functions of the power tool – that is, determine whether it can still perform its normal functions.

Check to see that the linkage of the moving parts is OK, that all parts are OK without damage, that they are properly mounted, and that the power tool functions normally. Should you find any damage to an accessory or part that may hamper proper functioning of the tool, please contact sales agent through which you have purchased your tool or an authorized dealer near you for repair.

- **Have your tool repaired at an authorized Nitto Service Centre.**

For repair or parts replacement, please contact sales agent through which you have purchased your tool or an authorized dealer near you.

- **Use only Nitto genuine parts.**

Use of improper parts may result in serious accident. To obtain a Nitto genuine part, consult this Manual or contact the sales agent from which you have purchased your tool directly.

- **Do not detach label or nameplate from tool.**

When a label/nameplate gets damaged, worn or becomes missing, contact the sales agent through which you have purchased your tool or Nitto Kohki Co. Ltd, directly for a replacement.

DISPOSAL

When a tool is taken permanently out of service, it is advised that the tool is disassembled, degreased and parts separated by material and recycled locally in the appropriate manner.

GENERAL: PNEUMATIC TOOLS

WARNING

- **Use appropriate air pressure.**

Excessively high air pressure will increase the number of revolutions or strokes causing not only potential premature failure/breakage but could also lead to an unexpected accident or injury.

- **Connect tool to air supply line.**

There are various types of pipes running in a factory in addition to the pneumatic line (such as oxygen, nitrogen, gas and water). For this reason, always ensure that you are connecting to the pneumatic line.

- **Start tool properly.**

Turn the start switch OFF before connecting to the air supply line.

- **Always disconnect the tool from the air supply line before putting on/taking off any accessory and prior to carrying out any maintenance work.**

- **Avoid exposure to exhaust air.**

Pneumatic tool exhaust air contains oil and contaminated moisture. Make sure the exhaust air is not directed towards your face or anyone else within the work area.

- **Keep tool off electricity.**

This pneumatic tool is not electrically insulated. To avoid a potential electric shock do not use where there is a possibility of coming into contact with live electricity.

CAUTION

- **Handle tool carefully.**

Abusive use of tool could invite failure or accident. Do not throw, drop or shock the tool.

- **Handle air hose carefully.**

Do not carry the tool by the air hose. Do not pull the air hose to disconnect.

INSTRUCTIONS FOR THIS TOOL

About Your Tool

WARNING

- **Protect your body from the chips/filings.**
Hot chips/filings may fly out from the work piece. Always wear safety glasses, dust mask, earplugs, gloves (except knitted gloves) and long-sleeved garment.
Keep your face well away from the work piece.
- **Do not use any Grinding Wheel with the rated speed (r/min) that is lower than the actual no load speed of the grinder. Make sure the dimensions of the Grinding Wheel you are using is applicable to the specification of the grinder.**
- **Make sure there are no cracks, chips or damage to the Grinding Wheel prior to use. Do not use any wheels wet or without labels.**
- **Use Nitto Kohki's Wheel Flanges only. However, do not use any of them which have cracks, chips or worn. Do not use the alternative flanges or flat washers.**
- **Make sure if the Grinding Wheel is adaptable to the Wheel Flanges.**
Do not use reducing bushing to meet the Wheel Lock unless they are supplied by the Grinding Wheel manufacturer.
- **Make sure there are no cracks, distortion or wear marks on the thread of the Spindle or Wheel Lock.**
The label on the wheel has to be the same or bigger diameter than that of a Spindle.
- **Make sure if there is any cracks, distortion or worn on a thread of a Spindle or Wheel Lock.**
Do not use the grinder if you ever find one.
- **Do not use the side of the Grinding Wheel (except for specific side use Grinding Wheels)**
- **Always use the Wheel Guard for the grinder if the maximum diameter of the Grinding Wheel is over 50mm.**
- **Use the Wheel Guard provided.**
Failure to do so could result in injury.
- **Replace damaged, bent or severely worn Wheel Guard. Do not use any Wheel Guard which can damage the Grinding Wheel.**
- **Air pressure for the grinder must not exceed 0.6MPa (6kgf/cm²).**
- **Do not start or stop grinders suddenly.**
Open a Throttle Lever gradually when you start operation.
- **After a grinder has been repaired and returned, check the no load speed with a tachometer before you use to make sure its actual speed at 0.6MPa (6kgf/cm²) does not exceed the rated**

speed printed on the Wheel Guard. Do the same check after each stage of the work process of work even in normal use. Set the Adjust Valve to the maximum speed position when you check the no load speed.

- **Only qualified/trained operators should attach or replace Grinding Wheels as well as checking/testing them.**
- **Release the Throttle Lever when air supply is stopped.**
- **Make sure no one is around grinding circumferences before trial running.**
- **Run a trial for a minute before start grinding and for three minutes after replacement of Grinding Wheels to make sure there is no problem on the grinder.**
- **Grind slowly until the Grinding Wheels get warmer in case Wheels seem cold at the start.**
- **Always operate the grinder at the correct angle. (15°~30°). (Fig.1)**

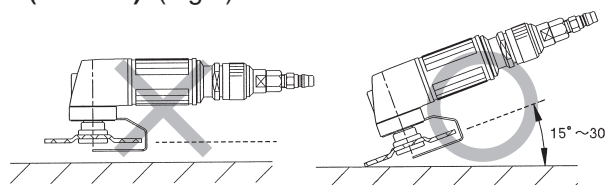

Fig.1

- **Do not put any inflammable liquid or use the grinding tool in a potentially explosive atmosphere as there is a possibility of sparks when grinding which could cause a fire/explosion.**

1. USAGE

This tool is for grinding workpieces using a Type 27 Depressed Center Abrasive Wheel.

2. CHECK THE CONTENTS OF THE PACKAGE

Check the contents and make sure that the tool does not have any damage which may have occurred during transportation. The contents should correspond to the list as follows. In case of damage/missing parts, please contact the sales agent from whom you purchased the tool.

MAG-25B

Package Contents	Qty	Check
MYTON MAG-25B	1	
Grinding Wheel AC #80	1	
Hex. Socket Screw Key 5	1	
Single Ended Spanner 14	1	
Bushing R1/4xNPT1/4	1	
Instruction Manual	1	
Declaration of Conformity	1	
Caution for Use	1	

MAGW-40

Package Contents	Qty	Check
MYTON MAGW-40	1	
Hex. Socket Screw Key 6	1	
Single Ended Spanner 17	1	
Bushing R3/8×NPT3/8	1	
Instruction Manual	1	
Declaration of Conformity	1	
Caution for Use	1	

MAG-50

Package Contents	Qty	Check
MYTON MAG-50	1	
Air Hose Sub Ass'y	1	
Exhaust Hose Ass'y	1	
Side Handle Ass'y	1	
Hex. Socket Screw Key 4	1	
Pin Face Wrench	1	
Bushing R3/8×NPT3/8	1	
Instruction Manual	1	
Declaration of Conformity	1	
Caution for Use	1	

MAG-70

Package Contents	Qty	Check
MYTON MAG-70	1	
Side Handle B	1	
Grip Guard B	1	
Hex. Socket Screw Key 6	1	
Hex. Socket Screw Key 10	1	
Single Ended Spanner 41	1	
Bushing R1/2×NPT1/2	1	
Instruction Manual	1	
Declaration of Conformity	1	
Caution for Use	1	

3. AIR SUPPLY

3-1. Air Pressure

Adjust air pressure with the air regulator to the appropriate level for the pneumatic tool used.

Air pressure that is too low will stop the tool from operating at full capacity.

Air pressure that is too high may cause damage to the tool.

3-2. Air Line (Fig.2)

Use a 9.5 mm (3/8") I.D. connecting hose between the compressor and the tool.

Drained water, etc., if flown into the tool, could cause tool failure. Install an air filter between the compressor and the tool.

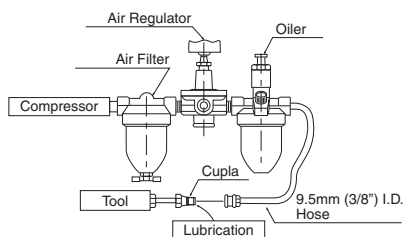

Fig.2

3-3. Lubrication

Install an oiler between the compressor and the tool. Use the machine oil ISO VG-10. Failure to lubricate as required may result in damage to the tool. Use of oil that is too thick will reduce the performance of the tool.

4. PREPARATION (MAG-50)

4-1. How to attach Inlet Hose and Exhaust Hose.

- Insert the Inlet Hose of the male thread into the Exhaust Hose from the tail.
- Screw the male thread of the Inlet Hose on the thread of the body. Then tighten enough with the tightening torque of 30N·m.
- Screw the Exhaust Hose on the body.

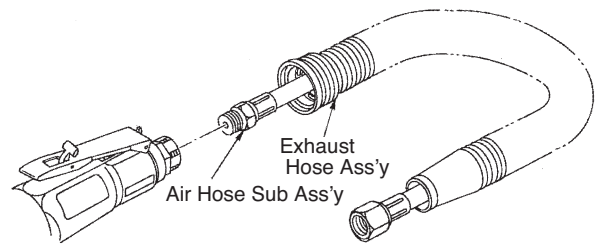

Fig.3

4-2. Thread Size of Hose Fitting

The product comes with a metal fitting with R(metric) thread. Connect the Bushing R thread×NPT thread in the vinyl bag containing standard accessories, if you would like to have American NPT thread instead.

4-3. Construction of Side Handle (MAG-50,MAG-70)

Before using MAG-50, MAG-70, you must set up Side Handle and Grip Guard indicated as follows.

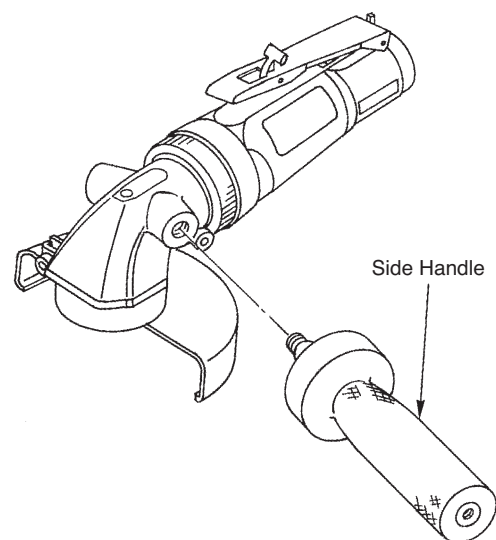

Fig.4

5. GRINDING WHEELS

WARNING

The maximum operating speed marked on the Grinding Wheel, blotters, or packaging, shall equal or exceed the rated speed on the grinder.
Use with Type 27 Depressed Center Grinding Wheels.

MAG-25B

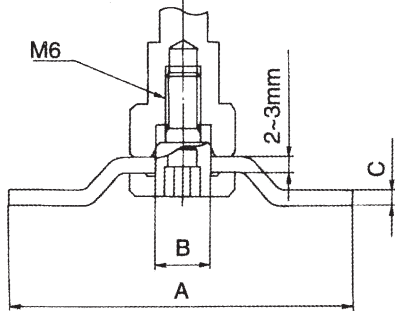

Fig.5

MAGW-40

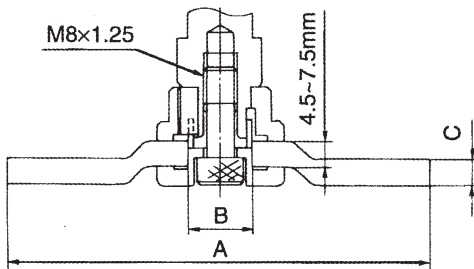

Fig.6

MAG-50

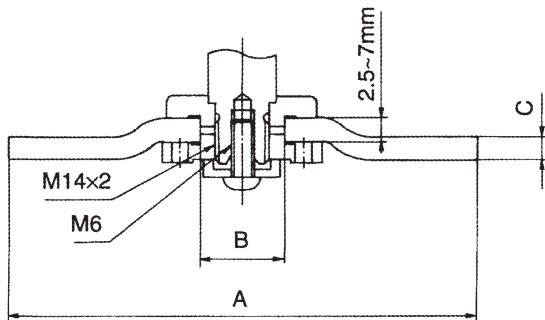

Fig.7

MAG-70

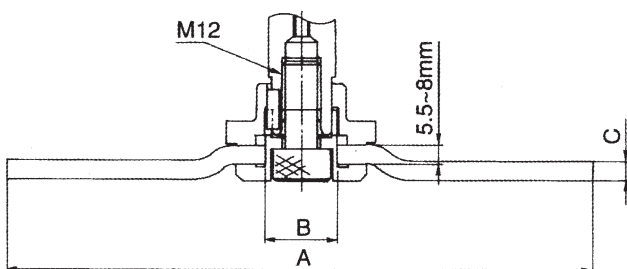

Fig.8

	MAG-25B	MAGW-40	MAG-50	MAG-70
A	58mm (2.3")	100mm (4")	125mm (5")	180mm (7")
B	9.6mm (3/8")	16mm (5/8")	22mm (7/8")	22mm (7/8")
C	3mm (1/6")	6mm (1/4")	6mm (1/4")	6mm (1/4")

A : Diameter of the Grinding Wheel

B : Hole of the Grinding Wheel

C : Thickness of the Grinding Wheel

6. MOUNTING AND REMOVING GRINDING WHEEL

WARNING

Always turn off the air supply and disconnect the air supply hose.

6-1. MAG-25B

Mounting

- 1 Hold the Spindle with Spanner supplied.
- 2 Insert the Outer Flange into the Grinding Wheel.
- 3 Secure it firmly to the Spindle by tightening the Outer Flange with Hex. Socket Screw Key.

Removal

Hold the Spindle with Spanner and loosen Outer Flange with Hex. Socket Screw Key to remove the Grinding Wheel.

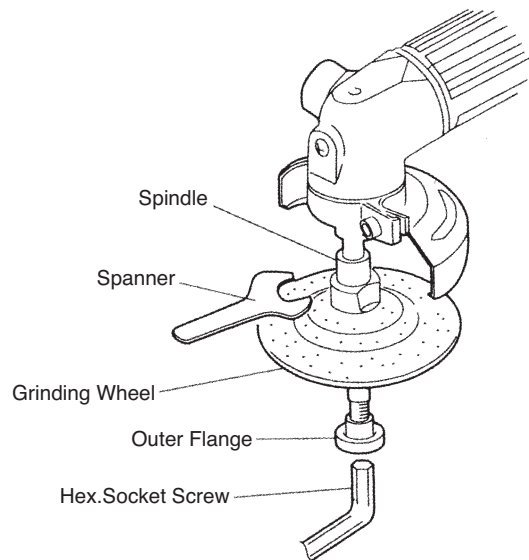

Fig.9

6-2. MAGW-40 & MAG-70

Mounting

- 1 Hold the Driving Flange with Spanner supplied.
- 2 Insert the Outer Flange into the Grinding Wheel, aligning the slot in the Outer Flange with the Key in the Driving Flange.
- 3 Secure it firmly to the Spindle by tightening the Wheel Lock Bolt with Hex. Socket Screw Key.

Removal

Hold the Driving Flange with Spanner and loosen Wheel Lock Bolt with Hex. Socket Screw Key to remove the Grinding Wheel.

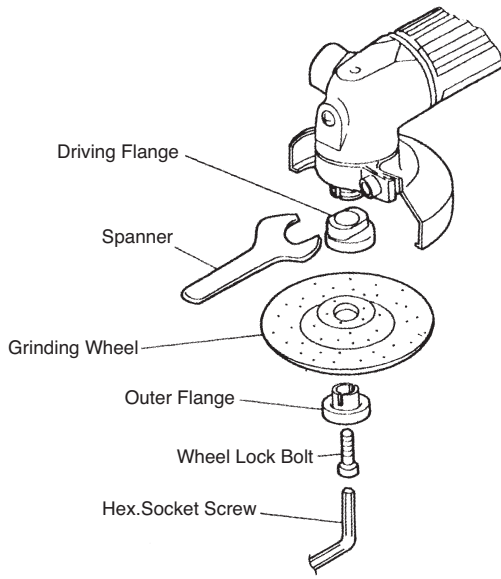

Fig.10

6-3. MAG-50

Mounting

- 1 Hold the Spindle with pushing the Lock Button.
- 2 Insert the Driving Flange into the Spindle to fit the convex on the Spindle and groove of the Driving Flange.
- 3 Insert the Grinding Wheel and Outer Flange into the Spindle.
- 4 In case the thickness of the Grinding Wheel is 4mm or less, attach the Outer Flange up side down.
- 5 Secure it firmly to the Spindle by tightening the Outer Flange with Pin Face Wrench.
- 6 Secure Washer and Hex. Socket Button Head Screw 6x15 firmly to the Spindle by tightening the Socket Button Head Screw 6x15 with Hex. Socket Screw Key.

Removal

- 1 Hold the Spindle with pushing the Lock Button.
- 2 Loosen the Hex. Socket Button Head Screw 6x15 with the Hex. Socket Screw Key and remove the Washer.
- 3 Loosen the Outer Flange with the Pin Face Wrench.

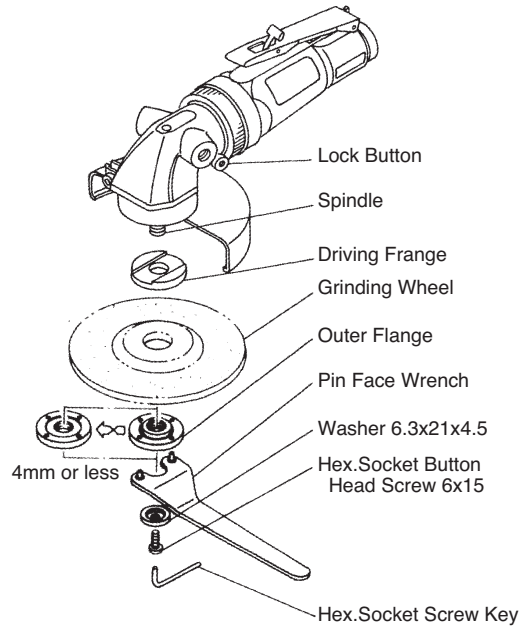

Fig.11

7. HOW TO OPERATE THE TOOL

7-1. Start and Stop

To start, release the Lock Lever and grasp the Throttle Lever.

To stop, release the Throttle Lever.

MAG-25B, MAG-50

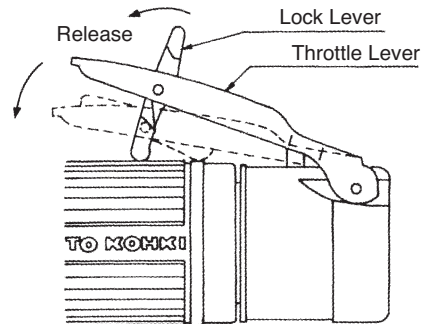

Fig.12

MAGW-40, MAG-70

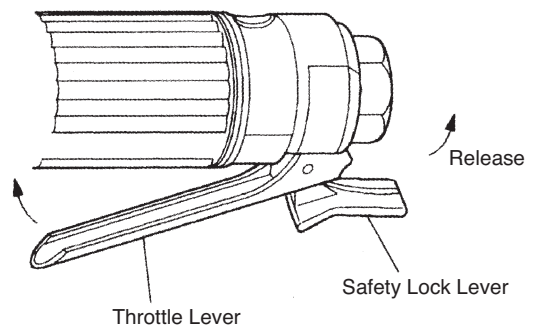

Fig.13

7-2. Adjust Valve (MAG-25B,MAGW-40,MAG-70)

WARNING

Be sure to keep hands clear of moving parts.

The desired number of rotation between maximum rpm and minimum rpm is obtained by turning the groove of valve clock wise or counterclockwise with screwdriver.

Maximum rotation

Position the groove of Adjust Valve horizontal to main body.

Minimum rotation

Position the groove of Adjust Valve vertical to main body.

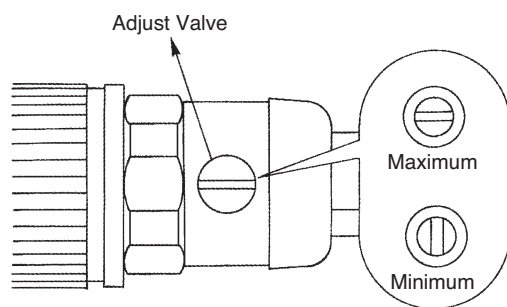

Fig.14

8. STORAGE

CAUTION

When tool is not used, store it out of children.

Avoid storing the tool in a location subject to high humidity. If the tool is left as it is used, residual moisture on the inside can cause rusting. Before storing, and after operation, oil the tool at the air inlet with machine oil ISO VG-10 and run it for a short time.

9. ORDERING SERVICE PARTS

- For further operational and handling information or for replacement of parts and components, contact the company from whom you purchased the tool or an authorized dealer.
- In ordering parts and components give each part number, part name and quantity required.
- Use only NITTO genuine parts.

10. OPTIONAL PARTS (MAGW-40)

Part No.	Description
TQ01051	Sub Handle (Standard Type)
TB03216	Side Handle Ass'y (Low Vibration Type)

11. EXPLODED DIAGRAM: MAG-25B

WARNING

This diagram is for your reference only. Do not attempt to service or repair the Tool.

Do not take the Tool apart. Contact an authorized Nitto dealer for all service and repair of the Tool.

Improper service and repair can cause accidents and service injuries.

Never attempt to modify the Tool.

Never attempt service or repair the Tool yourself.

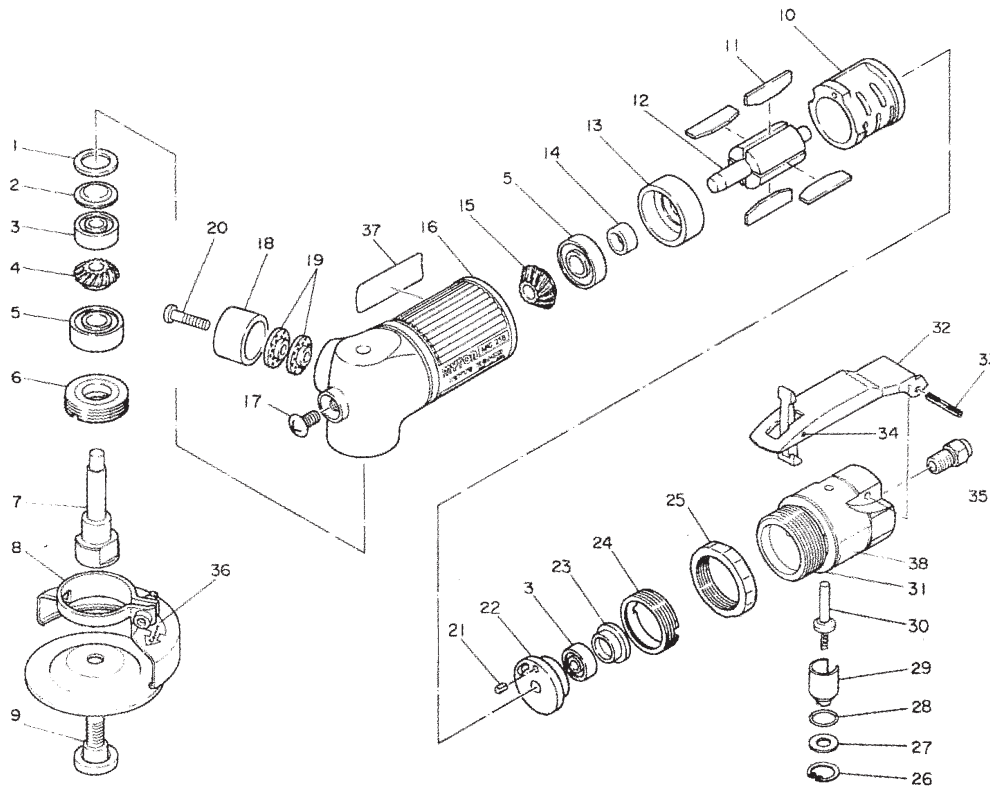

The part numbers with () are included in the Ass'y parts written above them.

No.	Part No.	Description	Qty	Price
1	TP10826	Packing	1	
2	TP10100	Bearing Cover	1	
3	TP03933	Ball Bearing 606ZZ	2	
4	TP14225	Gear	1	
5	TP00468	Ball Bearing 608ZZ	2	
6	TA98808	Bearing Set Screw Ass'y	1set	
7	TP17961	Spindle	1	
8	TB08774	Wheel Guard Ass'y	1set	
36	(TQ02362)	Label Warning for Wheel Guard	1	
9	TP17962	Outer Flange	1	
10	TP14222	Cylinder	1	
11	TA9A295	Blade Ass'y (4 pcs.)	1set	
12	TP14224	Rotor	1	
13	TP14931	End Plate B	1	
14	TP06322	Spacer 8×11×3	1	
15	TP14221	Pinion	1	
16	TB08643	Housing Ass'y	1set	
37	(TQ12676)	Label Warning CE Mark	1	
17	(TP06715)	Raised Countersunk Head Screw 5 × 8	1	
18	TP14227	Exhaust Cover	1	
19	TP14228	Exhaust Plate	2	
20	TP15164	Pan Head Screw 4×16	1	
21	TP00496	Spring Pin 2.5×6	1	

No.	Part No.	Description	Qty	Price
22	TP10109	End Plate A	1	
23	TP10110	Cap	1	
24	TP10098	Adapter	1	
25	TP03468	Lock Ring	1	
26	TP03695	Internal Retaining Ring C-12	1	
27	TP06326	Spacer 6×12×1.2	1	
28	TP11997	O-ring KS-7	1	
29	TP06325	Adjust Valve	1	
30	TA93070	Throttle Valve Ass'y	1set	
31	TB01251	Valve Body Sub Ass'y	1set	
38	(TQ02380)	Label Warning MAG-25B	1	
32	TB01152	Throttle Lever Ass'y	1set	
33	(TP00460)	Spring Pin 3×22	1	
34	(TP05498)	Spring Pin 2×16	1	

Accessories

No.	Part No.	Description	Qty	Price
		Abrasive Wheel AC #80	1	
	TP04004	Hex. Socket Screw Key 5	1	
	TP00475	Single Ended Spanner 14	1	
35	TP02236	Bushing R1/4×NPT1/4	1	
	TQ12677	Instruction Manual	1	
	TQ12678	Declaration of Conformity	1	

12. EXPLODED DIAGRAM: MAGW-40

⚠ WARNING

This diagram is for your reference only. Do not attempt to service or repair the Tool.

Do not take the Tool apart. Contact an authorized Nitto dealer for all service and repair of the Tool.

Improper service and repair can cause accidents and service injuries.

Never attempt to modify the Tool.

Never attempt service or repair the Tool yourself.

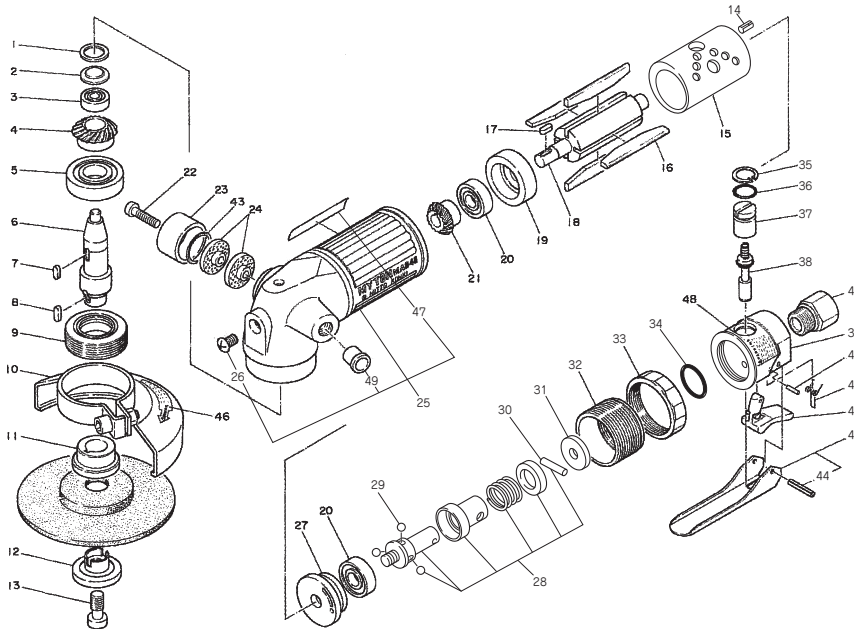

The part numbers with () are included in the Ass'y parts written above them.

No.	Part No.	Description	Qty	Price
1	TP10826	Packing	1	
2	TP10100	Bearing Cover	1	
3	TP03933	Ball Bearing 606ZZ	1	
4	TP14036	Gear	1	
5	TP01609	Ball Bearing 6202ZZ	1	
6	TP14035	Spindle	1	
7	TP00502	Parallel key Both Ends Round 4x4x9.5	1	
8	TP09933	Parallel key Both Ends Round 4x4x12	1	
9	TA98634	Bearing Set Screw Ass'y	1set	
10	TB08772	Wheel Guard Ass'y	1set	
46	(TQ02357)	Label Warning for Wheel Guard	1	
11	TQ00774	Driving Flange	1	
12	TQ00775	Outer Flange 16	1	
13	TP09932	Wheel Lock Bolt	1	
14	TP04061	Spring Pin 3x6	1	
15	TP14031	Cylinder	1	
16	TA9A294	Blade Ass'y(4pcs.)	1set	
17	TP10130	Parallel key Both Ends Round 3x3x10	1	
18	TP14033	Rotor	1	
19	TP14034	End Plate B	1	
20	TP10133	Ball Bearing 609ZZ	2	
21	TP14030	Pinion	1	
22	LP08450	Pan Head Screw 5x25	1	
23	TP14041	Exhaust cover	1	
24	TP14040	Silencer Plate	2	
25	TB08641	Housing Sub Ass'y	1set	
47	(TQ12676)	Label Warning CE Mark	1	

No.	Part No.	Description	Qty	Price
26	(TP06715)	Raised Countersunk Head Screw 5x8	1	
49	(LP30720)	Plug 9	1	
27	TP10137	End Plate A	1	
28	TA98635	Governor Ass'y	1set	
29	(CP01140)	Ball 7/32	4	
30	(TP07870)	Parallel Pin 3x15.8	1	
31	TP10149	Spring Washer MT-25	1	
32	TQ07319	Governor Adapter	1	
33	TQ07320	Lock Ring	1	
34	TP05531	O-ring S-36	1	
35	TP03473	Internal Retaining Ring C-14	1	
36	TP11992	O-ring KS-9	1	
37	TP04394	Adjust Valve	1	
38	TB15591	Throttle Valve Ass'y	1set	
39	TB05592	Valve Body Ass'y	1set	
40	TP09434	Spring Pin 2x12	1	
48	(TQ07316)	Label Warning	1	
41	TP14340	Helical Torsion Spring	1	
42	TP14339	Lock Lever	1	
43	TB05590	Throttle Lever Ass'y	1set	
44	(TP01921)	Spring Pin 3x18	1	
45	TQ02349	Bushing M16xR3/8	1	

Accessories

No.	Part No.	Description	Qty	Price
	TP00170	Hex.Socket Screw Key 6	1	
	TP00474	Single Ended Spanner 17	1	
	TQ12677	Instruction Manual	1	
	TQ12678	Declaration of Conformity	1	
	TQ02350	Bushing R3/8xNPT3/8	1	

13. EXPLODED DIAGRAM: MAG-50

⚠ WARNING

This diagram is for your reference only. Do not attempt to service or repair the Tool.

Do not take the Tool apart. Contact an authorized Nitto dealer for all service and repair of the Tool.

Improper service and repair can cause accidents and service injuries.

Never attempt to modify the Tool.

Never attempt service or repair the Tool yourself.

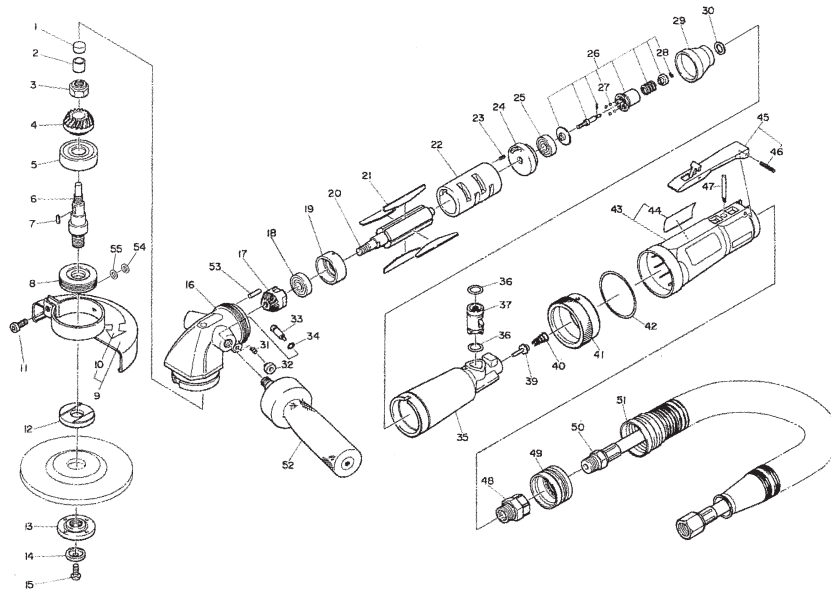

The part numbers with () are included in the Ass'y parts written above them.

No.	Part No.	Description	Qty	Price
1	TQ04100	Bearing Cover	1	
2	TQ04099	Needle Bearing HK0810	1	
3	TQ04107	Hex. Nut M10 U Nut	1	
4	TQ04415	Gear 1.25x29	1	
5	TP04201	Ball Bearing 6302ZZ	1	
6	TQ04105	Spindle	1	
7	TQ04106	Parallel Key Both Ends Round 4x4x8	1	
8	TB03202	Bearing Set Screw Ass'y	1set	
9	TB08773	Wheel Guard Ass'y	1set	
10	(TQ04121)	Label Warning for Wheel Guard	1	
11	(TQ12840)	Hex. Socket Head Cap Screw 6x20 with groove for Retaining Ring	1	
54	(TP14930)	Retaining Ring E 2.3	1	
55	(TP02152)	Washer M5	1	
12	TQ04123	Driving Flange	1	
13	TQ04124	Outer Flange	1	
14	TQ04139	Wahser 6.3x21x4.5	1	
15	TP14688	Hex. Socket Button Head Screw 6x15	1	
16	TQ06043	Geer Head	1	
17	TQ04414	Pinion 1.25x19	1	
18	TP00498	Ball Bearing 6001ZZ	1	
19	TQ04091	End Plate B	1	
20	TQ04087	Rotor	1	
21	TB03297	Blade Ass'y (4 pcs.)	1set	
22	TQ04088	Cylinder	1	
23	TP04061	Spring Pin 3x6	1	
24	TQ04090	End Plate A	1	
25	TP00468	Ball Bearing 608ZZ	1	
26	TB03198	Governor Ass'y	1set	
27	(CP01181)	Ball 5/32	4	
28	(TP14930)	Retaining Ring E ETW-2.3	1	

No.	Part No.	Description	Qty	Price
29	TQ04907	Governor Cover	1	
30	TQ04110	Washer 9x14x2.2	1	
31	TQ04103	Spring 0.6x8.3x13.75	1	
32	TQ04104	Lock Button	1	
33	TQ04101	Sprindle Lock	1	
34	TQ04102	O-Ring SS-060	1	
35	TQ04109	Housing	1	
36	TP11998	O-Ring P-12	2	
37	TQ04111	Adjust Valve	1	
39	TB03205	Throttle Valve Ass'y	1set	
40	CP00876	Valve Spring	1	
41	TQ04112	Lock Ring	1	
42	TP06625	O-Ring G-45	1	
43	TB08648	Grip Tube Ass'y	1set	
44	(TQ12406)	Label Warning CE Mark	1	
45	TB01388	Throttle Lever Ass'y	1set	
46	(TP00460)	Spring Pin 3x22	1	
47	TQ04115	Throttle Pin	1	
48	TQ04119	Bushing M16xRc3/8	1	
49	TQ04130	Exhaust Hose Mount	1	
51	TQ04129	Exhaust Hose	1	
53	TP12618	Needle Roller 3x11.8	1	

Accessories

No.	Part No.	Description	Qty	Price
50	TB03208	Air Hose Sub Ass'y	1set	
	TB03209	Exhaust Hose Ass'y	1set	
52	TB03216	Side Handle Ass'y	1set	
	TP01939	Hex. Socket Screw Key 4	1	
	TQ04125	Pin Face Wrench	1	
	TQ02350	Bushing R3/8xNPT3/8	1	
	TQ12677	Instruction Manual	1	
	TQ12678	Declaration of Conformity	1	

14. EXPLODED DIAGRAM: MAG-70

⚠ WARNING

This diagram is for your reference only. Do not attempt to service or repair the Tool.

Do not take the Tool apart. Contact an authorized Nitto dealer for all service and repair of the Tool.

Improper service and repair can cause accidents and service injuries.

Never attempt to modify the Tool.

Never attempt service or repair the Tool yourself.

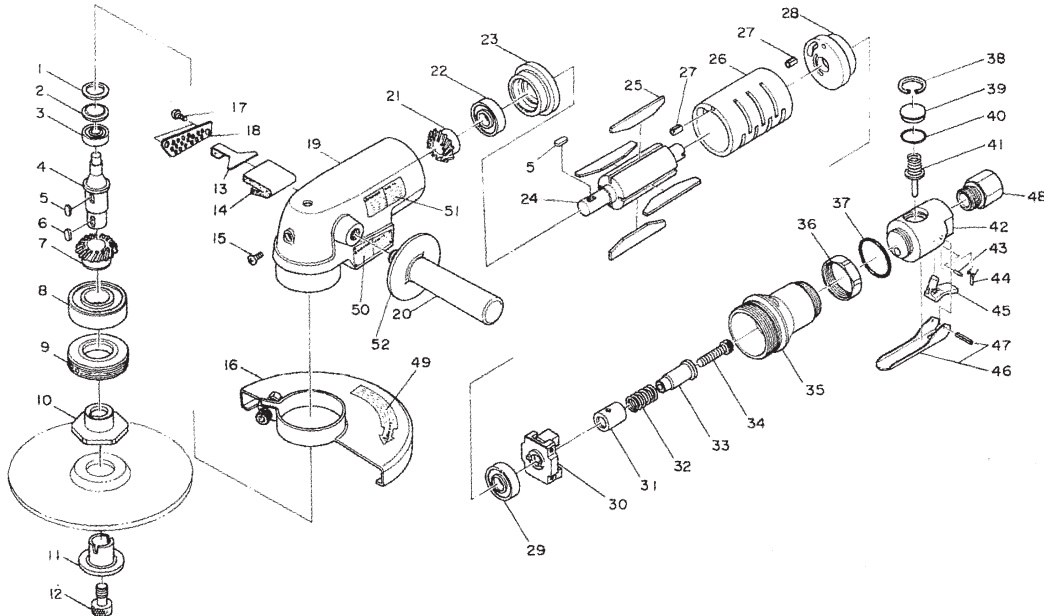

The part numbers with () are included in the Ass'y parts written above them.

No.	Part No.	Description	Qty	Price
1	TP11687	Packing	1	
2	TP11685	Bearing Cover	1	
3	TP00468	Ball Bearing 608ZZ	1	
4	TP11708	Spindle	1	
5	TP00502	Parallel Key Both Ends Round 4x4x9.5	2	
6	TP09933	Parallel Key Both Ends Round 4x4x12	1	
7	TP11709	Gear	1	
8	TP11707	Ball Bearing 6304ZZ	1	
9	TA97016	Bearing Set Screw Ass'y	1set	
10	TQ00772	Driving Flange	1	
11	TQ00771	Outer Flange	1	
12	TP11688	Wheel Lock Bolt	1	
13	TP12260	Filter Support	1	
14	TP12261	Filter	1	
15	TP06715	Raised Countersunk Head Screw 5x8	1	
16	TB08776	Wheel Guard Ass'y	1set	
49	(TQ12491)	Label Warning for Wheel Guard	1	
17	TP02618	Pan Head Screw 4x8	2	
18	TP11691	Exhaust Cover	1	
19	TB08777	Housing Sub Ass'y	1set	
50	(TQ02384)	Name Plate MAG-70	1	
51	(TQ12490)	Label Warning CE Mark	1	
20	TA90586	Side Handle Ass'y	1set	
52	TQ02387	Grip Guard B	1	
21	TP11694	Pinion	1	
22	TP11701	Ball Bearing 6201DD	1	
23	TP11700	End Plate B	1	
24	TP11697	Rotor	1	
25	TA9A292	Blade Ass'y (4 pcs.)	1set	

No.	Part No.	Description	Qty	Price
26	TP11699	Cylinder	1	
27	TP04061	Spring Pin 3x6	2	
28	TP11696	End Plate A	1	
29	TP11695	Ball Bearing 6201ZZ	1	
30	TA97298	Base Ass'y	1set	
31	TP11705	Sleeve	1	
32	TP11706	Spring 1.8x13.7x25.5	1	
33	TP11704	Sleeve Guide	1	
34	TP05648	Hex. Socket Head Cap Screw 5x45	1	
35	TA9A765	Valve Holder Sub Ass'y	1set	
36	TP17452	Lock Ring	1	
37	TP17445	O-Ring S-35.5	1	
38	TP10448	Internal Retaining Ring C-24	1	
39	TP10444	Valve Cap	1	
40	TP10714	O-Ring S-22	1	
41	TA96331	Throttle Valve Ass'y	1set	
42	TP16235	Valve Body	1	
43	TP09434	Spring Pin 2x12	1	
44	TP14340	Helical Torsion Spring	1	
45	TP14339	Lock Lever	1	
46	TA96253	Throttle Lever Ass'y	1	
47	TP01921	Spring Pin 3x18	1	
48	TQ02414	Bushing M22xR1/2	1	

Accessories

No.	Part No.	Description	Qty	Price
	TP00170	Hex. Socket Screw Key 6	1	
	TQ02427	Bushing R1/2xNPT1/2	1	
	TP11723	Hex. Socket Screw Key 10	1	
	TP11724	Single Ended Spanner 41	1	
	TQ12677	Instruction Manual	1	
	TQ12678	Declaration of Conformity	1	



■ Overseas Affiliates / Offices

NITTO KOHKI U.S.A ., Inc.

4525 Turnberry Drive, Hanover Park, IL 60133, U.S.A

Tel: (1)-630-924-9323 Fax:(1)-630-924-0303
<http://www.nittokohki.com/index.html>

NITTO KOHKI EUROPE Co., Ltd.

Unit 21, Empire Centre, Imperial Way,
Watford Hertfordshire, WD24 4TS, United Kingdom

Tel: (44)-01923-239668 Fax:(44)-01923-248815
<http://www.nitto.co.uk/>

NITTO KOHKI DEUTSCHLAND GmbH

Lerchenstr. 47, D-71144 Steinenbronn, Germany

Tel: (49)-7157-22436 Fax:(49)-7157-22437
<http://www.nitto-kohki.de/>

NITTO KOHKI AUSTRALIA Pty. Ltd.

77 Brandl Street, Eight Mile Plains QLD 4113,
Australia

Tel: (61)-7-3340-4600 Fax:(61)-7-3340-4640
<http://www.nitto-australia.com.au/>

NITTO KOHKI Co., Ltd. Singapore Branch

10 Ubi Crescent #01-62, Ubi Techpark Lobby D,
Singapore 408564

Tel: (65)-6227-5360 Fax:(65)-6227-0192
<http://www.nitto-kohki.co.jp/e/nksb/>

NITTO KOHKI Co., Ltd. Shanghai Representative Office

#1117 Ruijing Building, Maoming South Road,
Shanghai 200020 China

Tel: (86)-21-6415-3935 Fax:(86)-21-6472-6957
<http://www.nitto-kohki.cn/>

NITTO KOHKI Co., Ltd. Shenzhen Representative Office

#0726 International Culture Building, 3039, Shennan
Zhong Rd., FutianDistrict, Shenzhen, 518003 China

Tel: (86)-755-8375-2185 Fax:(86)-755-8375-2187
<http://www.nitto-kohki.cn/>

NITTO KOHKI Co., Ltd. Bangkok Representative Office

38Q, House Convent Bldg, 7th Floor, Unit 7A,
Convent Rd, Silom, Bangkok, 10500 Thailand

Tel: (66)-2-632-0307 Fax:(66)-2-632-0308
http://www.nittobkk.com/eng_index.htm

EC DECLARATION OF CONFORMITY

We hereby declare that the following our product conforms with the essential health and safety requirements of EEC Directives.

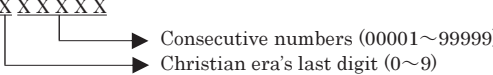
Product: PNEUMATIC ANGLE GRINDER
Model: MAYTON:MAG·25B, MAGW·40, MAG·50 and MAG·70
Serial No: XXXXXX

Manufacturer: NITTO KOHKI Co., Ltd.
2·9·4, Nakaikegami, Ohta·ku, Tokyo, 146·8555, Japan
Authorised Compiler in the Community:
Masatoshi Ogue
President
NITTO KOHKI EUROPE Co., Ltd.
Unit21, Empire Centre, Imperial Way, Watford Hertfordshire, WD24 4TS, UK
Tel:(44)·01923·239668 Fax:(44)·01923·248815
Directive: 98/37/EC and 2006/42/EC Machinery Directive

The above product has been evaluated for conformity with above directives using the following European standards.

The technical construction file (TCF) for this product is retained at the above manufacturer's location.

Machinery Directive: EN ISO12100·1:2003, EN ISO12100·2:2003,
EN ISO14121·1:2007, EN792·7:2001+A1:2008, others
Sound Pressure/Power Level: EN ISO15744:2008, EN ISO4871:1996
Vibration Level: EN28662·1:1992, EN ISO8662·4:1997

Name: K.Kishi
Title: GENERAL MANAGER MACHINE TOOLS DIV.

Being the responsible person appointed and employed the manufacturer.