

Datasheet

Compact Power

1 port valve electric actuator



Assembly Instructions:

Quick Direct Assembly on RuB s.31 mini valve:

1. Push the spring clip in order to set the actuator in open position
2. Assemble the actuator on top of valve
3. Pull spring clip to lock actuator on valve

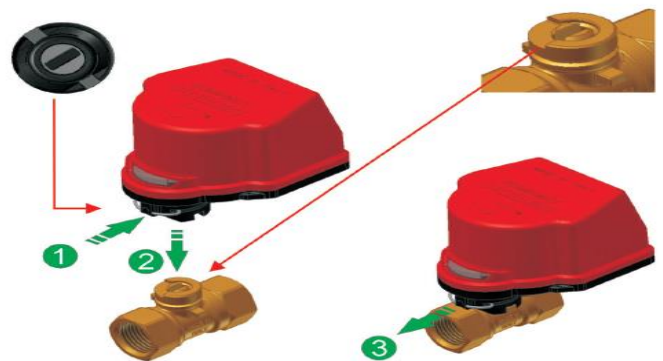

Assembly on RuB s.64 and s.74 valves:

1. Position the ball of the valve to match the position (open / closed) of the actuator
2. Mount stem adaptor (B) and F03 adaptor (A) on top of valve flange and fix it with two screws and nuts (C)
3. Push the spring clip in order to set the actuator in open position
4. Assemble the actuator on top of adaptor
5. Pull spring clip to lock actuator on valve

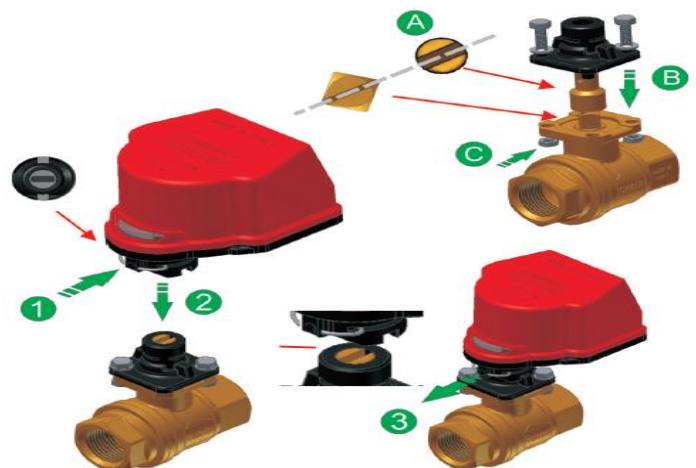

Technical Features:

- Suitable for RuB actuatable valves up to 1.1/4" size (only for s.64 LT)
- Compact package to fit in restricted spaces
- Power supply 230V AC 50Hz / 24V AC 50-60Hz
- Motor power consumption 10W
- Torque output up to 5 Nm (44 in-lb)
- Operation time 20 to 25 sec
- Working temperature -20°C (-4°F) +80°C (+180°F)
- Protection class IP65 comparable to NEMA 4X
- Micro-switches for open-close signals
- Micro-switches can pass up to 1A
- Reversing motor
- Direct mount on valve for perfect shaft alignment
- Positive orientation between ball valve and actuator
- Actuator easily removable for manual operating
- Visual position indicator
- Corrosion resistant plastic housing
- Actuator has successfully passed 100,000 cycle life tests
- Duty cycle 60%

Options:

- Power supply 110V AC 60Hz
- Adaptor F03 square 8 mm

Example:

CP5A3 is an CP actuator, 5 Nm 230V AC, 3-WIRES with connection screw driver male and adaptor ISO 5211 F03 square 9 mm

CP5A3-1 is an CP actuator, 5 Nm, 230V AC, 3-WIRES with connection screw driver male and adaptor ISO 5211 F03 square 8 mm

How to order:

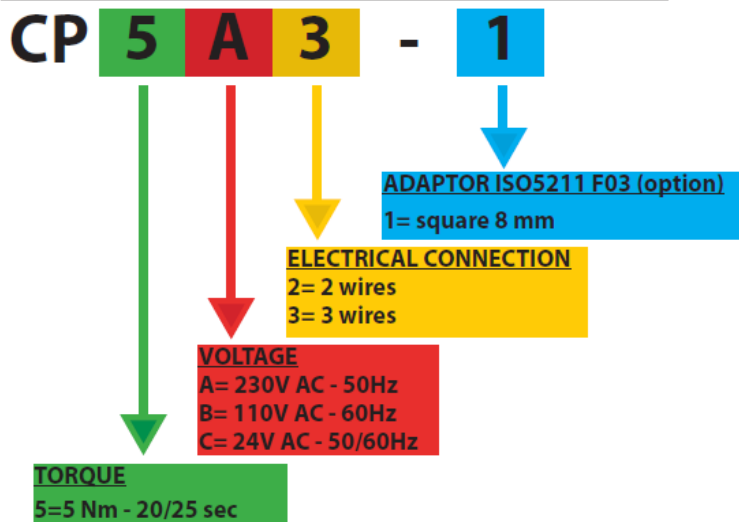

Dimension mm:

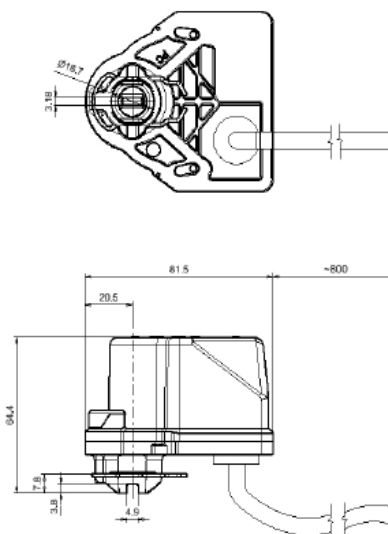
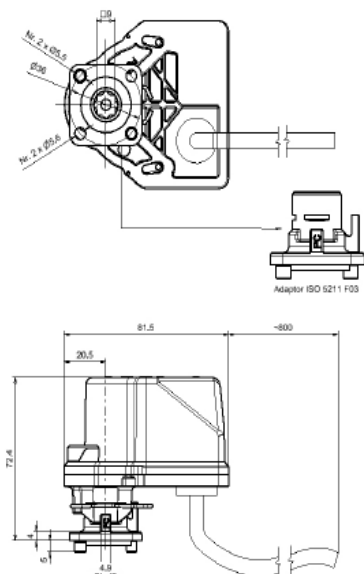
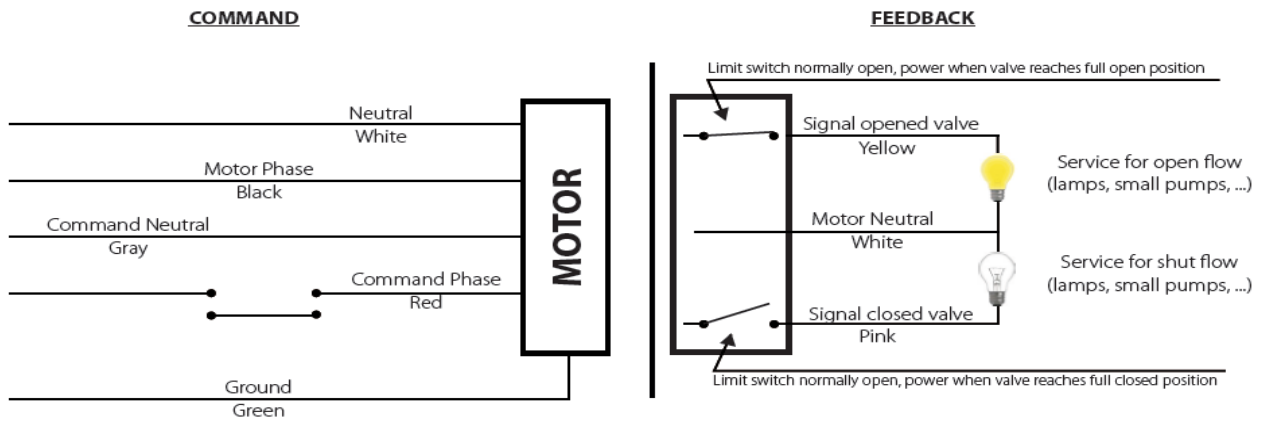

DIAGRAM FOR 2-WIRE CONTROL (ONLY CW CLOSING)



2 point command : the command is made by a simple switch or button (manually or automatically operated e.g. Traditional thermostat). Closing the control switch will cause the actuator to travel to the full CCW position. Opening the control switch will cause the actuator to travel to the full CW position. If the actuator is mounted on a ball valve, closing the control switch will open the ball valve, and vice versa. Upon request, the command voltage may differ from the motor power voltage.

DIAGRAM FOR 3-WIRE CONTROL (CW CLOSING)

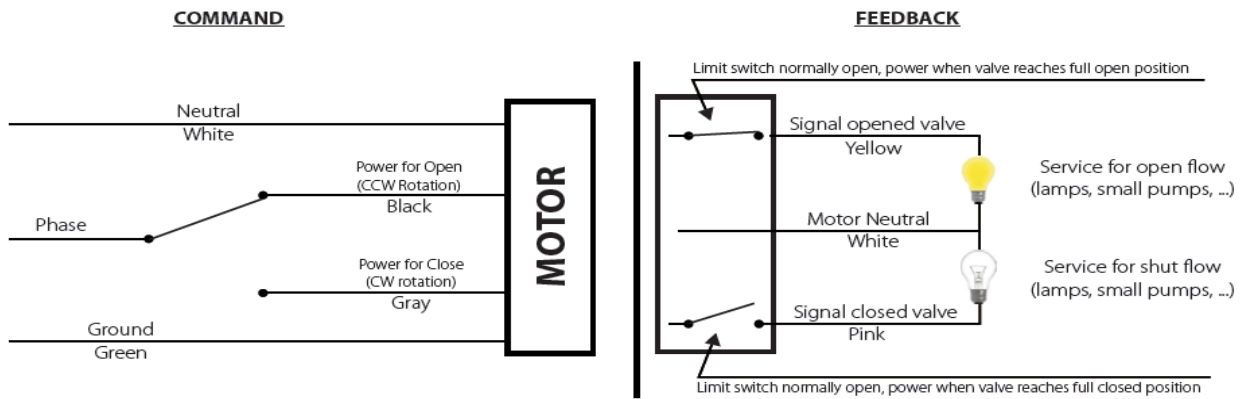
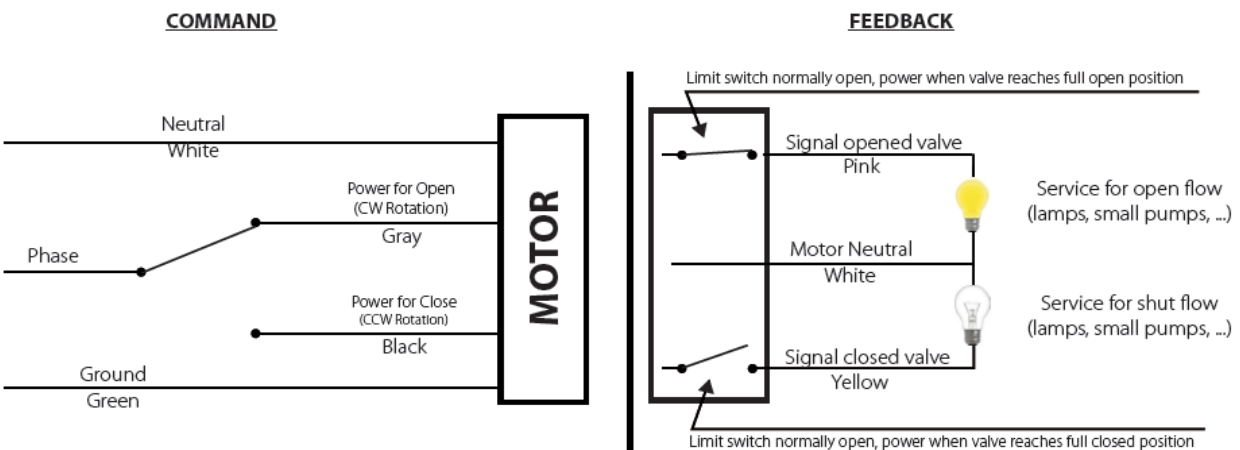

DIAGRAM FOR 3-WIRE CONTROL (CCW CLOSING)



Note: If the limit switch signals are not to be used the yellow and pink wires must be capped to prevent accidental short circuits

3 point command: the command is made by a switch (manually or automatically operated e.g. 3 points thermostat), which diverts the voltage to the opening wire or to the closing wire reaching the actuator; the switch may be on open or on closed position; using a specific control, engine can stop in any intermediate position.