

# Non Isolated Board Mount DC / DC Converters

**multicomp** PRO

**RoHS  
Compliant**

Wide input voltage non-isolated and regulated single output

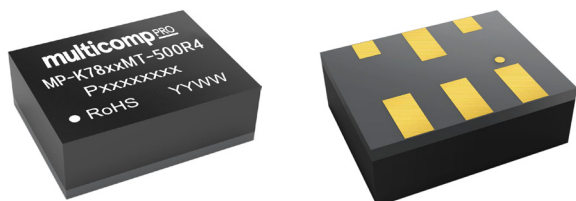

## Features

- Ultra-small, ultra-thin DFN package(9mm x 7mm x 3mm)
- Operating ambient temperature range: -40°C to +105°C
- High efficiency up to 92%
- No-load input current as low as 0.1mA
- Output short-circuit protection
- Meets AEC-Q100 (under testing)
- EN62368 approved
- No heat sink required
- 0.5A DFN Package
- Short circuit protection
- Low ripple and noise
- MTBF: 9152k hours (Mil-HDBK-217F @ 25°C)
- 3 Years Warranty

## Description

The MP-K78\_MT-500R4 series are high efficiency switching regulators. The converters feature high efficiency, low loss and short-circuit protection in a compact DFN package. These products are widely used in applications such as industrial control, instrumentation and electric power.

Selection Guide					
Part Number	Input Voltage (VDC)*	Output		Full Load Efficiency (%) Vin Min. / Vin Max.	Capacitive Load (µF) Max.
	Nominal (Range)	Voltage (VDC)	Current (mA) Max.		
MP-K7803MT-500R4	24 (4.5-36)	3.3	500	89/79/71	680
MP-K7803MT-500R4(100)	12 (7-32)	-3.3	-300	80/82/71	470
MP-K7805MT-500R4	24 (6.5-36)	5	500	91/83/78	680
MP-K7805MT-500R4(100)	12 (7-31)	-5	-300	78/78/71	470
MP-K7812MT-500R4	24 (15-36)	12	500	92/91/86	680
MP-K7812MT-500R4(100)	12 (8-24)	-12	-150	81/83/79	470

Note: \* For input voltage exceeding 30V DC, an input capacitor of 22µF/50V is required.

Input Specifications					
Item	Operating Conditions	Min.	Typ.	Max.	Unit
No-load Input Current	Nominal input voltage	--	0.1	--	mA
Reverse Polarity at Input		Avoid / Not protected			
Input Filter		Capacitance filter			
Ctrl*	Module on	Ctrl pin open or pulled high(TTL 2.5~5VDC)			
	Module off	Ctrl pin pulled low to GND(-Vo)(0~0.6VDC)			
Ctrl*	Input current when off	--	240		µA

Note: \*The positive output ctrl pin voltage is referenced to input GND; Negative output ctrl pin voltage is referenced to -Vo.

Newark.com/multicomp-pro  
Farnell.com/multicomp-pro  
Element14.com/multicomp-pro

**multicomp** PRO

# Non Isolated Board Mount DC / DC Converters

**multicomp** PRO

Output Specifications						
Item	Operating Conditions	Min.	Typ.	Max.	Unit	
Voltage Accuracy	Full load, input voltage range	3.3V DC output	--	±2	±4	%
		Others	--		±3	
Linear Regulation	Full load, input voltage range	--	±0.2	--		
Load Regulation	Nominal input , 10% -100% load	--	±0.4	--		
Ripple & Noise*	20MHz bandwidth, nominal input voltage, full load	--	20	45	mVp-p	
Temperature Coefficient	Operating temperature -40°C to +105°C	--	±0.02	--	%/°C	
Transient Response Deviation	Nominal input, 25% load step change	--	50	120	mV	
Transient Recovery Time		--	0.2	0.8	ms	
Short-circuit Protection		Continuous, self-recovery				
Vtrim	Input voltage range					

Note: \* The "parallel cable" method is used for ripple and noise test, please refer to DC-DC Converter Application Notes for specific information;

General Specifications					
Item	Operating Conditions	Min.	Typ.	Max.	Unit
Operating Temperature	See Fig. 1	-40	--	+105	°C
Storage Temperature		-55	--	+125	
Storage Humidity	Non-condensing	5	--	95	%RH
Reflow Soldering Temperature		Peak temperature ≤245°C, duration ≤60s max. over 217°C. Also refer to IPC/JEDEC J-STD-020D.1.			
Switching Frequency	Full load, nominal input	--	2	--	MHz
MTBF	MIL-HDBK-217F@25°C	9152	--	--	K hours
Moisture Sensitivity Level (MSL)	IPC/JEDEC J-STD-020D.1	Level 3			
Pollution Degree		PD3			

Mechanical Specifications	
Case Material	Black epoxy resin; flame-retardant and heat-resistant(UL94 V-0)
Dimensions	9mm × 7mm × 3.1mm
Weight	0.58g(Typ.)
Cooling Method	Free air convection

Electromagnetic Compatibility (EMC)			
Emissions	CE	CISPR32/EN55032	CLASS B (see Fig. 3-2 for recommended circuit)
	RE	CISPR32/EN55032	CLASS B (see Fig. 3-2 for recommended circuit)
Immunity	ESD*	IEC/EN 61000-4-2	Contact ±6KV perf. Criteria B
	RS	IEC/EN 61000-4-3	10V/m perf. Criteria A
	CS	IEC/EN 61000-4-6	3Vr.m.s perf. Criteria A
	EFT	IEC/EN 61000-4-4	±1KV (see Fig. 3-1 for recommended circuit) perf. Criteria B
	Surge	IEC/EN 61000-4-6	line to line ±1KV (see Fig. 3-1 for recommended circuit) perf. Criteria B

Note: \* The static level of the Ctrl & Trim pin is ±2KV when they are not connected to external devices; It is suggested to connect an external capacitor (105K/50V) from Ctrl to GND/-Vo to meet ESD (±6KV) of the Ctrl pin, and to connect a varistor (22V/30A) from Trim to GND/-Vo to meet ESD(±6KV) of the Trim pin.

Newark.com/multicomp-pro  
Farnell.com/multicomp-pro  
Element14.com/multicomp-pro

**multicomp** PRO

# Non Isolated Board Mount DC / DC Converters

**multicomp** PRO

## Typical Characteristic Curves

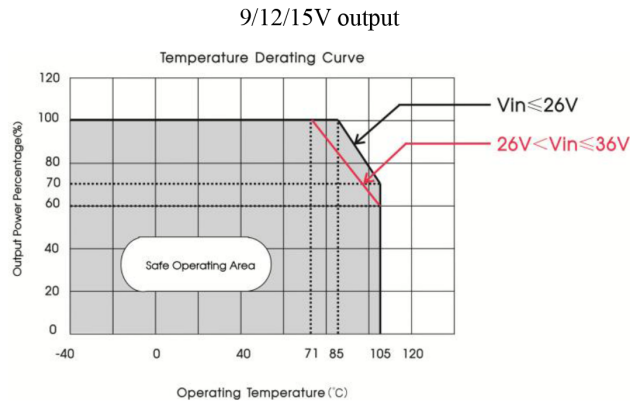
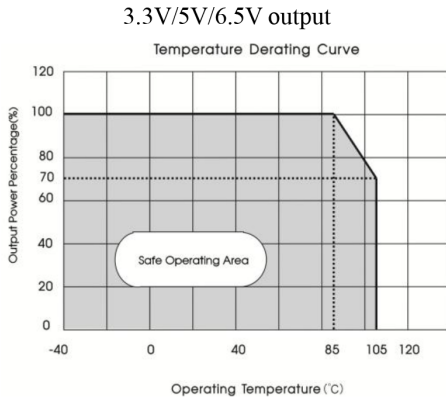
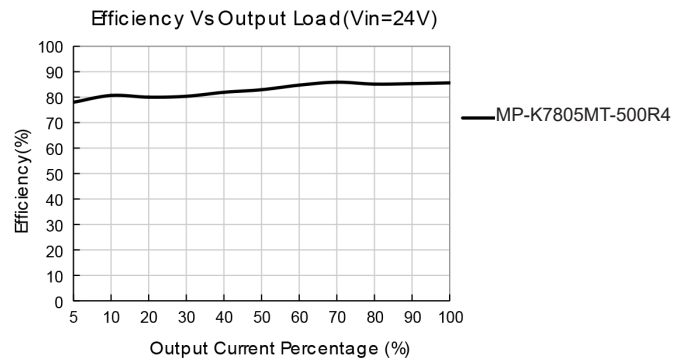
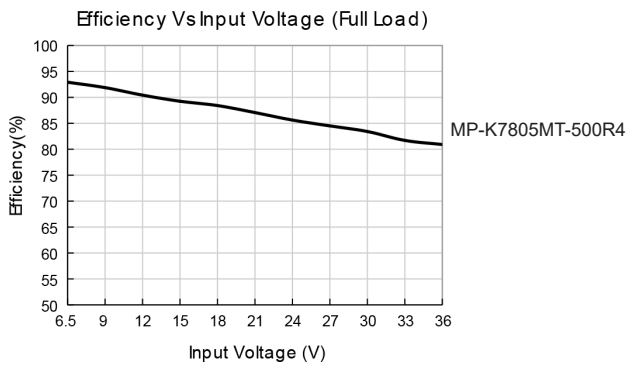

Fig. 1



## Design Reference

### 1. Typical application

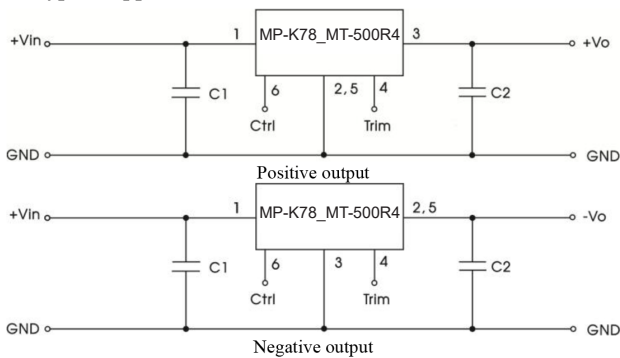

Fig. 2 Typical application circuit

### Notes:

1. The required C1 and C2 capacitors must be connected as close as possible to the terminals of the module;
2. Refer to Table 1 for C1 and C2 capacitor values. For certain applications, increased values and/or tantalum or low ESR electrolytic capacitors may also be used instead;
3. Converter cannot be used for hot swap and with output in parallel.

Table 1

Part Number	C1/C3 (ceramic capacitor)	C2/C4 (ceramic capacitor)
MP-K7803MT-500R4 MP-K7803MT-500R4(100)	10μF/50V	22μF/10V
MP-K7805MT-500R4 MP-K7805MT-500R4(100)		
MP-K7812MT-500R4 MP-K7812MT-500R4(100)		22μF/25V

Newark.com/multicomp-pro  
Farnell.com/multicomp-pro  
Element14.com/multicomp-pro

**multicomp** PRO

# Non Isolated Board Mount DC / DC Converters

## 2. EMC compliance circuit

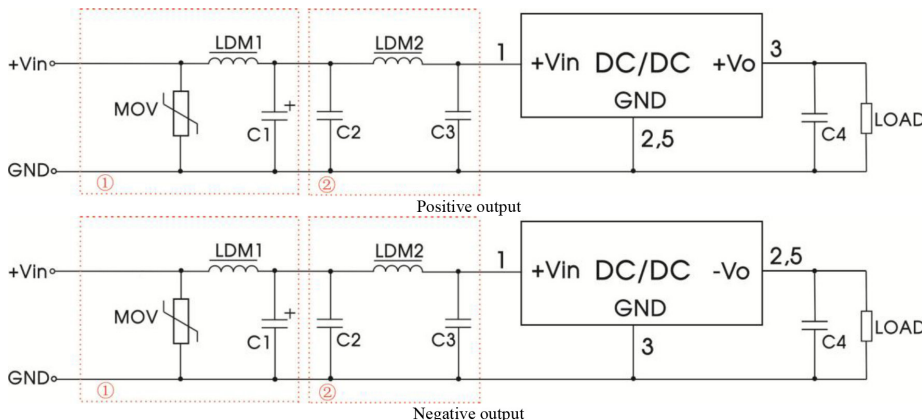

Fig.3 Recommended compliance circuit

Part No.	MOV	LDM1	C1	C2	LDM2	C3	C4
MP-K7803MT-500R4 MP-K7803MT-500R4(100) (Positive output)	S20K30	82μH	680μF /50V	10μF/50V	10μH	0.47μF/50V	22μF/10V
MP-K7803MT-500R4 MP-K7803MT-500R4(100) (Negative output)					22μH	--	
MP-K7805MT-500R4 MP-K7805MT-500R4(100)					10μH	--	
MP-K7812MT-500R4 MP-K7812MT-500R4(100)					22μH	0.47μF/50V	

Notes: For EMC tests we use Part 1 in Fig.3 for immunity and part 2 for emissions test. Selecting based on needs.

## 3. Trim Function for Output Voltage Adjustment (open if unused)

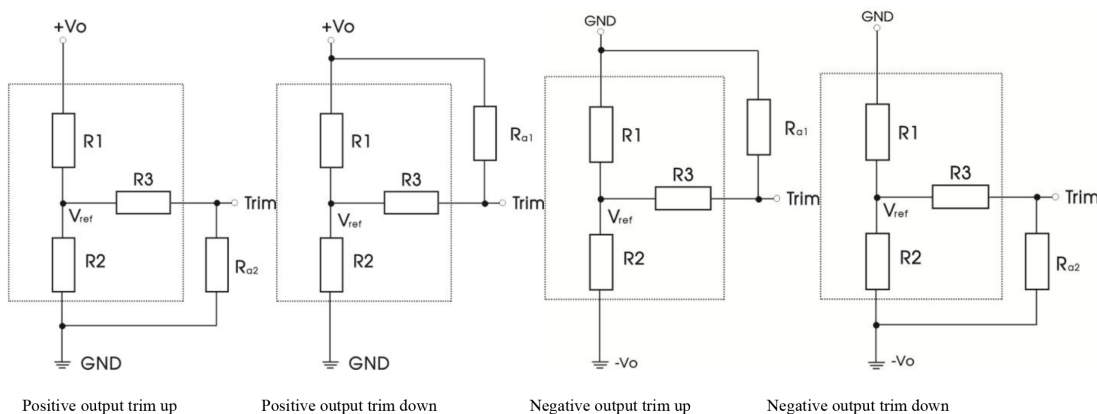

Fig.4 Circuit diagram of Vtrim up and down (dashed line shows internal part of module)

Calculating Trim resistor values:

$$\text{Trim up: } R_{a2} = \frac{aR_2}{R_2 - a}, \quad a = R_2 // (R_3 + R_{a2}) = \frac{V_{ref}}{V_o' - V_{ref}} R_1$$

$$\text{Trim down: } R_{a1} = \frac{aR_1}{R_1 - a}, \quad a = R_1 // (R_3 + R_{a1}) = \frac{V_o' - V_{ref}}{V_{ref}} R_2$$

# Non Isolated Board Mount DC / DC Converters

**multicomp** PRO

Vout(V)	R1(KΩ)	R2(KΩ)	R3(KΩ)	Vref(V)
3.3	47	15	82	0.8
5	36	6.875	36	0.8
6.5	47	6.596	36	0.8
9	75	7.318	47	0.8
12	120	8.571	51	0.8
15	100	5.634	36	0.8

Vout nom.	±3.3V DC		±5V DC		±6.5V DC		±9V DC		±12V DC		±15V DC	
Vout adj.	Ra1	Ra2	Ra1	Ra2	Ra1	Ra2	Ra1	Ra2	Ra1	Ra2	Ra1	Ra2
2.97	221k											
3.63		34k										
4.5			236k									
5.5				20k								
5.85					329k							
7.15						22k						
8.1							562k					
9.9								19k				
10.8									948k			
13.2										29k		
13.5											811k	
16.5												17k

# Non Isolated Board Mount DC / DC Converters



## Dimensions and Recommended Layout

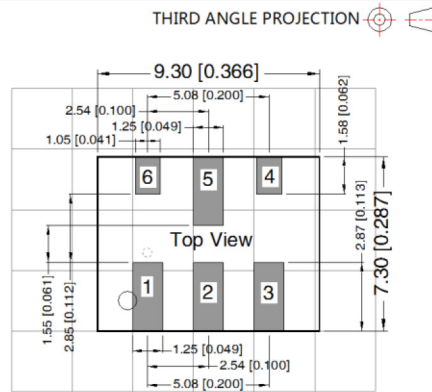
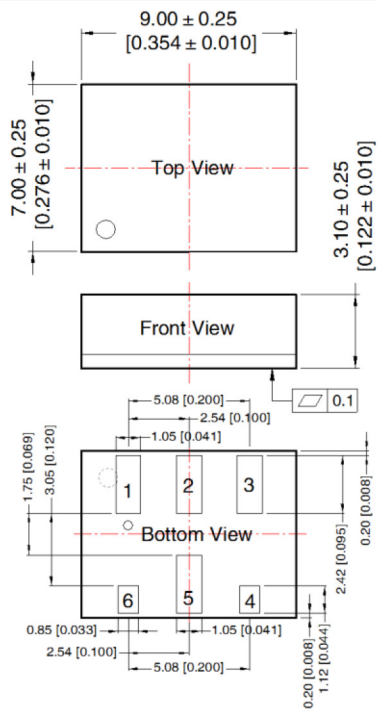

Note: Grid 2.54\*2.54mm

Pin-Out		
Pin	Positive output	Negative output
1	+Vin	+Vin
2	GND	-Vo
3	+Vo	GND
4	Trim	Trim
5	GND	-Vo
6	Ctrl	Ctrl

Note:  
Unit :mm[inch]  
Pin diameter tolerances : ± 0.10[ ± 0.004]

**Important Notice :** This data sheet and its contents (the "Information") belong to the members of the AVNET group of companies (the "Group") or are licensed to it. No licence is granted for the use of it other than for information purposes in connection with the products to which it relates. No licence of any intellectual property rights is granted. The Information is subject to change without notice and replaces all data sheets previously supplied. The Information supplied is believed to be accurate but the Group assumes no responsibility for its accuracy or completeness, any error in or omission from it or for any use made of it. Users of this data sheet should check for themselves the Information and the suitability of the products for their purpose and not make any assumptions based on information included or omitted. Liability for loss or damage resulting from any reliance on the Information or use of it (including liability resulting from negligence or where the Group was aware of the possibility of such loss or damage arising) is excluded. This will not operate to limit or restrict the Group's liability for death or personal injury resulting from its negligence. Multicomp Pro is the registered trademark of Premier Farnell Limited 2019.

Newark.com/multicomp-pro  
Farnell.com/multicomp-pro  
Element14.com/multicomp-pro

