

FEATURES

- All Fluids compatible
- Mechanical resistance
- Silicon free

RS PRO TAPER NIPPLE (3 PIECES)

RS Stock No.: 2312533



RS PROfessionally Approved Products bring to you professional quality parts across all product categories. Our product range has been tested by engineers and provides a comparable quality to the leading brands without paying a premium price.

Product Description

The RS PRO taper nipple (3 pieces) mainly used in compressed air, pneumatic automation, industrial water circuit applications. High performances in pressure and temperatures (+300°C). Available with sharp threads. RoHS and REACH compliant.

General Specifications

Fitting Type	Nipple
Material	Brass
Fitting Direction	Straight
Application	Compressed Air, Pneumatic Automation, Industrial water circuits, Inert Gases, Fluids, Steam Vacuum

Mechanical Specifications

Pipe Fitting Connection Type	Threaded
Connection 1	3/8 in BSP Male
Connection Gender 1	Male
Thread Size 1	3/8 in
Thread Standard 1	BSP
Connection 2	3/8 in BSP Male
Connection Gender 2	Male
Thread Size 2	3/8 in
Thread Standard 2	BSP
Length	36.5mm
Wrench Size	22mm

Operation Environment Specifications

Temperature	Min.	Max.
	- 20°C	+80°C

Similar Products

Parameters	2312532	2312534
Brand	RS PRO	RS PRO
Pipe Fitting Connection Type	Threaded	Threaded
Connection 1	1/4 in BSPP Male	1/2 in BSP Male
Connection Gender 1	Male	Male
Thread Size 1	1/4 in	1/2 in
Thread Standard 1	BSPP	BSP
Connection 2	1-1/4 in BSP Male	1/2 in BSP Male
Connection Gender 2	Male	Male
Thread Size 2	1-1/4 in	1/2 in
Thread Standard 2	BSP	BSP
Length	33.5mm	45mm
Wrench Size	19mm	27mm

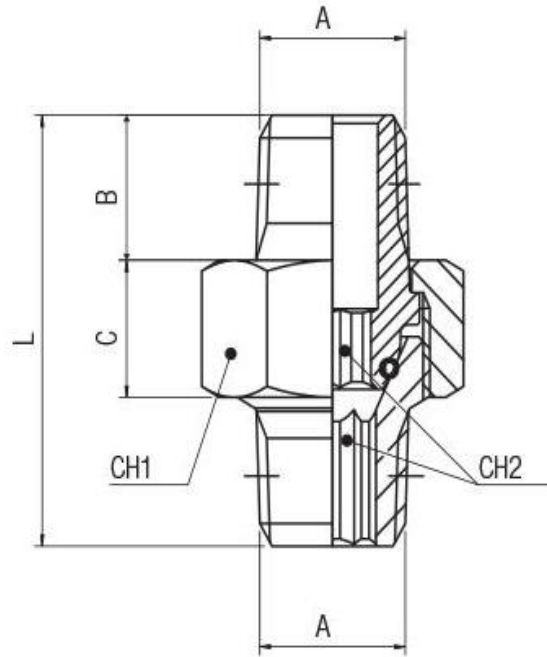

A	B	C	D	L	CH1	CH2	Pack
13	10	11.5	36.5	22	8	20	10