

Click [here](#) to ask about the production status of specific part numbers.

MAX20474

3.0V to 5.5V Input, 6V to 18V Output, Synchronous Boost Converter

General Description

The MAX20474 is a high-efficiency DC-DC converter which boosts 3.0V to 5.5V input supply from 6V to 18V at up to 1A load. The boost converter achieves $\pm 1.5\%$ output error over load, line, and temperature range.

The device features a 2.2MHz fixed-frequency PWM mode for better noise immunity and load transient response as well as a pulse-frequency modulation mode (skip) for increased efficiency during light-load operation. The 2.2MHz frequency operation allows for the use of all ceramic capacitors and minimizes external components. The programmable spread-spectrum frequency modulation minimizes radiated electromagnetic emissions. Integrated low $R_{DS(ON)}$ switches improve efficiency at heavy loads and make planning the layout a much simpler task with respect to discrete solutions.

Other features include true shutdown, soft-start, overcurrent, and over-temperature protections.

Applications

- Automotive Point of Load

Benefits and Features

- Synchronous Boost Converter for Small Solution Size
 - 4.0A Peak Input Current
 - Resistor Adjustable Output Voltage from 6V to 18V
 - 6V to 18V Fixed Output Selection in 0.25V Steps
 - 3.0V to 5.5V Operating Supply Voltage
 - 2.2MHz Operation
 - RESET Output
 - Spread Spectrum
- High-Precision
 - $\pm 1.5\%$ Output Voltage Accuracy, Fixed
 - $\pm 2.2\%$ Output Voltage Accuracy, Adj
 - $81 \pm 3\%$ UV Monitoring
 - $121 \pm 3\%$ OV Monitoring
 - Good Load Transient Performance
- Robust for the Automotive Environment
 - Current Mode, Forced PWM, and SKIP Operation
 - Over Temperature & Short Circuit Protection
 - 3mm x 3.5mm 14-Pin TDFN
 - 40°C to +125°C Automotive Temperature Range

Ordering Information appears at end of datasheet.

Simplified Block Diagram

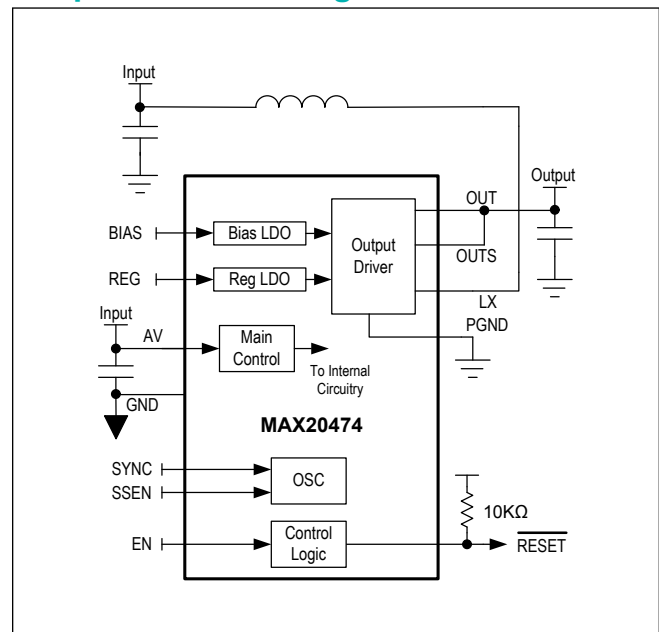

TABLE OF CONTENTS

General Description	1
Applications	1
Benefits and Features	1
Simplified Block Diagram	1
Absolute Maximum Ratings	4
Package Information	4
TDFN	4
Electrical Characteristics	4
Typical Operating Characteristics	6
Pin Configuration	9
MAX20474	9
Pin Description	9
Functional Diagrams	10
Internal Block Diagram	10
Detailed Description	11
Enable Input (EN)	11
RESET Output	11
Internal Oscillator	11
Synchronization (SYNC)	11
Soft-Start	11
Current Limit / Short-Circuit Protection	12
PWM/SKIP Modes	12
Over-Temperature Protection	12
OUTS Pin Considerations	12
BIAS Pin Considerations	12
REG Pin Considerations	13
Applications Information	14
Input Capacitor	14
Inductor Selection	14
Boost Output Capacitor	14
External Feedback Resistors	15
Typical Application Circuits	15
Applications Circuit - Fixed Output	15
Typical Applications Circuit - Adjustable 12V Output	16
Ordering Information	16
Revision History	17

MAX20474 3.0V to 5.5V Input, 6V to 18V Output, Synchronous
Boost Converter

LIST OF TABLES

Table 1. REG Pin Capacitance Recommendations for Short Circuit Protection 13

Absolute Maximum Ratings

EN, SYNC, SSEN, BIAS, AV, RESET to GND.....	-0.3V to +6V	Continuous Power Dissipation (T _A = +70°C, derate 22.15mW/°C above +70°C).....	1771.87mW
OUTS, OUT to PGND.....	-0.3V to +22V	Operating Temperature Range.....	-40°C to +125°C
REG to OUT.....	-6V to OUT + 0.3V	Junction Temperature.....	+150°C
LX to PGND.....	-0.3V to OUT + 0.3V	Storage Temperature Range.....	-40°C to +150°C
GND to PGND.....	-0.3V to +0.3V	Soldering Temperature (Reflow).....	+260°C
LX Continuous RMS Current.....	4A		
Output Short-Circuit Duration.....	Continuous		

Note 1: Self-protected from transient voltages exceeding these limits in circuit under normal operation.

Note 2: Package thermal resistances were obtained using the method described in JEDEC specification JESD51-7, using a four-layer board. For detailed information on package thermal considerations, refer to www.maximintegrated.com/thermal-tutorial.

Stresses beyond those listed under "Absolute Maximum Ratings" may cause permanent damage to the device. These are stress ratings only, and functional operation of the device at these or any other conditions beyond those indicated in the operational sections of the specifications is not implied. Exposure to absolute maximum rating conditions for extended periods may affect device reliability.

Package Information

TDFN

Package Code	T143A3+1C
Outline Number	21-100420
Land Pattern Number	90-100149
Thermal Resistance, Four-Layer Board:	
Junction to Ambient (θ _{JA})	45.15°C/W
Junction to Case (θ _{JC})	7.54°C/W

For the latest package outline information and land patterns (footprints), go to www.maximintegrated.com/packages. Note that a "+", "#", or "-" in the package code indicates RoHS status only. Package drawings may show a different suffix character, but the drawing pertains to the package regardless of RoHS status.

Package thermal resistances were obtained using the method described in JEDEC specification JESD51-7, using a four-layer board. For detailed information on package thermal considerations, refer to www.maximintegrated.com/thermal-tutorial.

Electrical Characteristics

(V_{AV} = 5V, EN = 5V, T_A = T_J = -40°C to +125°C, V_{OUT} = 12V, Typical values are at T_A = +25°C under normal conditions unless otherwise noted. (Note 2)

Limits over the operating temperature range and relevant supply voltage range are guaranteed by design and characterization. Specifications marked "GBD" are guaranteed by design and not production tested.)

PARAMETER	SYMBOL	CONDITIONS	MIN	TYP	MAX	UNITS
Supply Voltage Range	V _{IN}		3		5.5	V
AV_UVLO Rising	AV_UVLOR	AV Rising			2.5	V
AV_UVLO Falling	AV_UVLOF	AV Falling		2.2		V
Shutdown Supply Current	I _{SHDN}	EN = LOW, SYNC = LOW, T _A = 25°C		1		µA
Supply Current	I _{IN}	EN = HIGH, I _{OUT} = 0mA, SYNC = LOW		400		µA
PWM Switching Frequency	f _{SW}	Internally Generated	2	2.2	2.4	MHz
Spread Spectrum	SS	SSEN enabled		±3		%
OUT						
Output Voltage Accuracy	V _{OUT}	PWM mode, I _{LOAD} = 0A to I _{MAX} , Internal Feedback	-1.5		+1.5	%
		PWM mode, I _{LOAD} = 0A to I _{MAX} , External Feedback	-2.2		+2.2	

Electrical Characteristics (continued)

($V_{AV} = 5V$, $EN = 5V$, $T_A = T_J = -40^{\circ}C$ to $+125^{\circ}C$, $V_{OUT} = 12V$, Typical values are at $T_A = +25^{\circ}C$ under normal conditions unless otherwise noted. (Note 2)

Limits over the operating temperature range and relevant supply voltage range are guaranteed by design and characterization. Specifications marked "GBD" are guaranteed by design and not production tested.)

PARAMETER	SYMBOL	CONDITIONS	MIN	TYP	MAX	UNITS
Feedback Voltage Accuracy	V_{OUT}	PWM mode, $I_{LOAD} = 0A$ to I_{MAX}	794	812	830	mV
PMOS On-Resistance	RHS	$V_{AV} = 3.3V$, $ILX = 1.0A$		150		m Ω
NMOS On-Resistance	RLS	$V_{AV} = 3.3V$, $ILX = 1.0A$		100		m Ω
NMOS Current-Limit Threshold	ILIM2		3.0	4.0	5.0	A
LX Leakage Current	I_{LXLKG}	LX = PGND or OUT, $T_A = 25^{\circ}C$		0.1		μA
Maximum Duty Cycle	DC _{MAX}		88			%
OUT Discharge Resistance	RDISCH	VEN = 0V (connected to OUT) POWER DISSIPATION		300		Ω
SKIP Threshold	THSKIP	Percentage of NMOS current-limit threshold		25		%
Soft-Start Time	t_{SS}			1.9		ms
THERMAL OVERLOAD						
Thermal Shutdown Temperature	TSHDN	T_J rising		165		$^{\circ}C$
Hysteresis	THYST			15		$^{\circ}C$
RESET						
OV Threshold	OVACC	Rising, % of nominal output	118	121	124	%
UV Threshold	UVACC	Falling, % of nominal output	78	81	84	%
Active Hold Period	tHOLD	Option 1 (default)		0.5		ms
OV/UV Delay Filter	tOVUVDEL	10% below/above threshold		10		μs
Output-High Leakage Current	IRLKG	$T_A = 25^{\circ}C$		0.1		μA
Output Low Level	VROL	sinking -2mA			0.2	V
EN, SSEN, AND SYNC INPUTS						
Input High Level	VIH		1.5			V
Input Low Level	VIL				0.5	V
Input Hysteresis	VHYST			0.1		V
SYNC Input Pull-down	RSYNCPD	EN high		100		k Ω
SYNC Input Frequency Range	fSYNC		1.7		2.6	MHz
EN Pull-down Current				1		μA

Note 3: Package thermal resistances were obtained using the method described in JEDEC specification JESD51-7, using a 4-layer board. For detailed information on package thermal considerations see <http://www.maxim-ic.com/thermal-tutorial>.

Note 4: All units are 100% production tested at $+25^{\circ}C$. All temperature limits are guaranteed by design.

Typical Operating Characteristics

(T_A = 25°C)

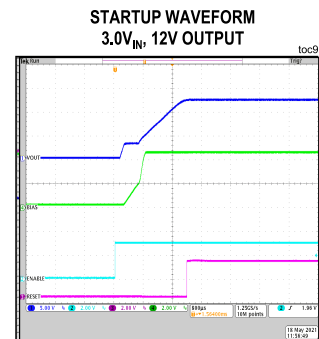
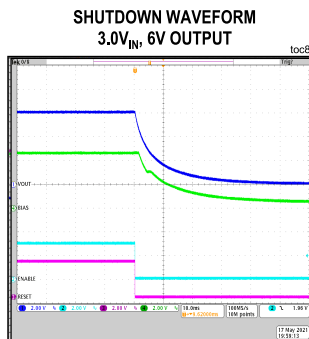
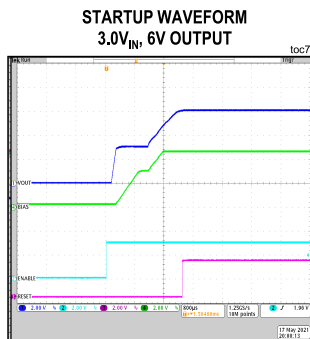
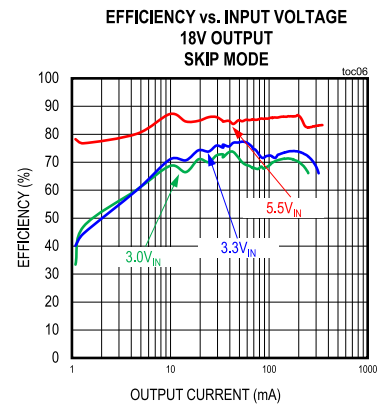
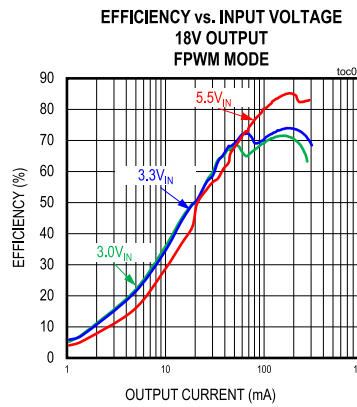
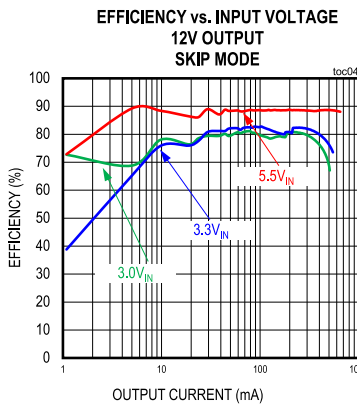
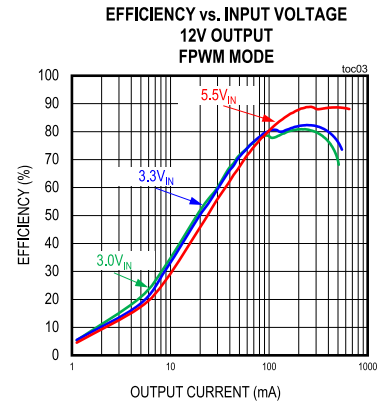
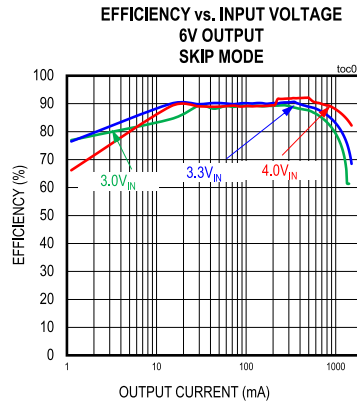
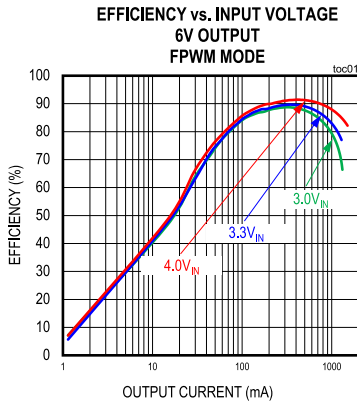

Typical Operating Characteristics (continued)

(T_A = 25°C)

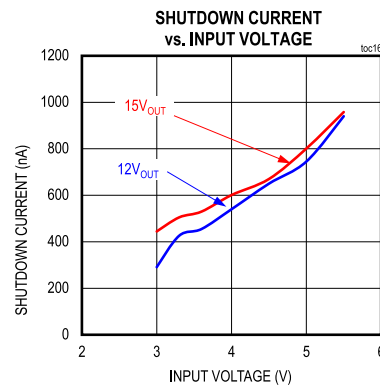
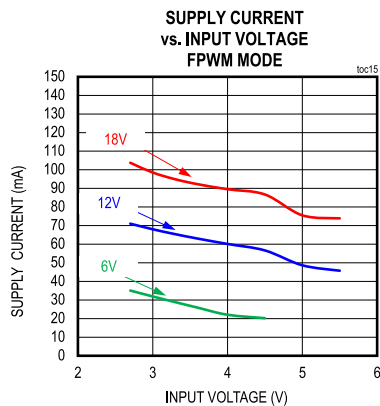
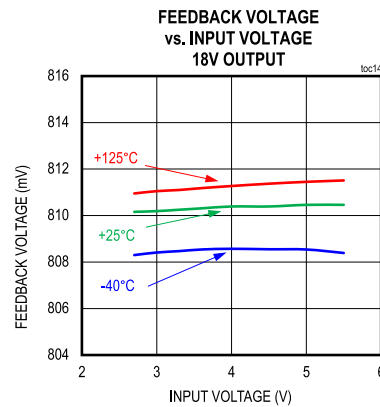
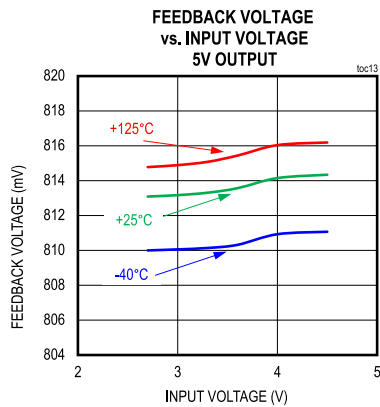
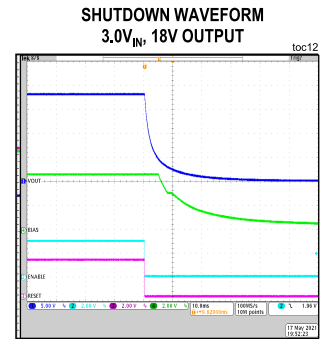
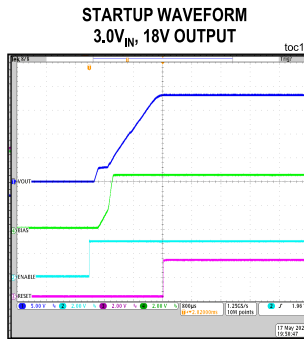
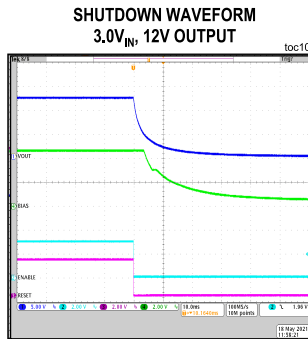

Typical Operating Characteristics (continued)

(T_A = 25°C)

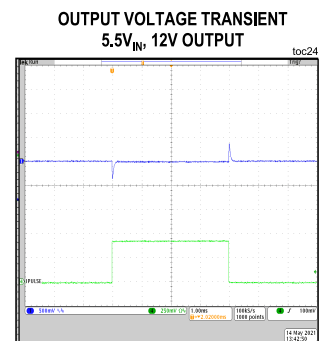
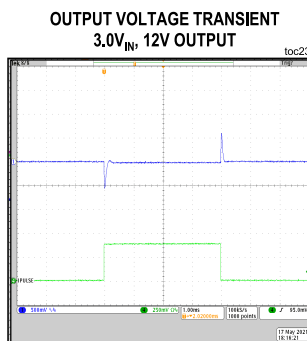
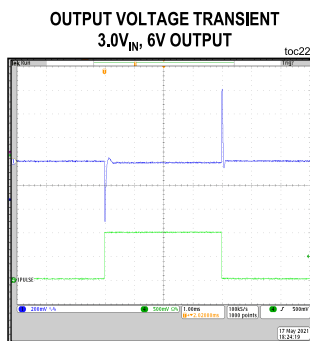
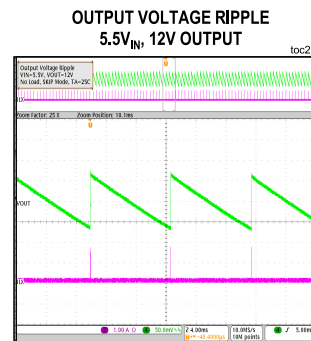
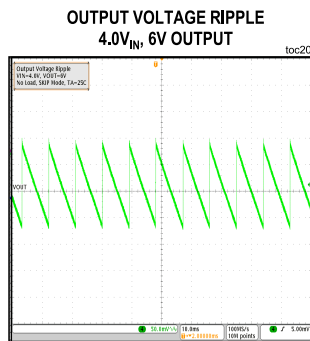
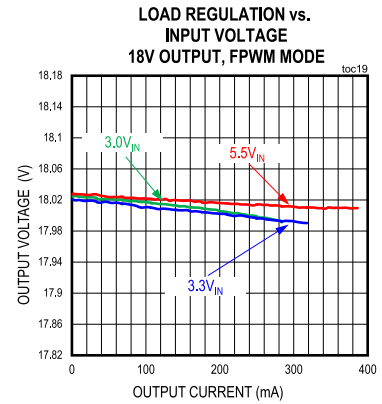
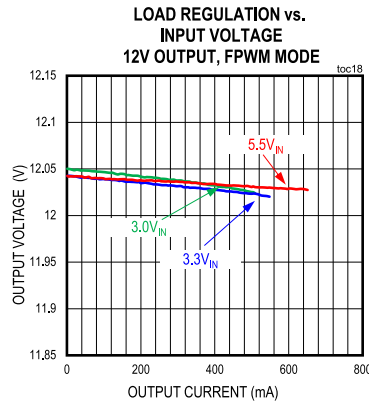
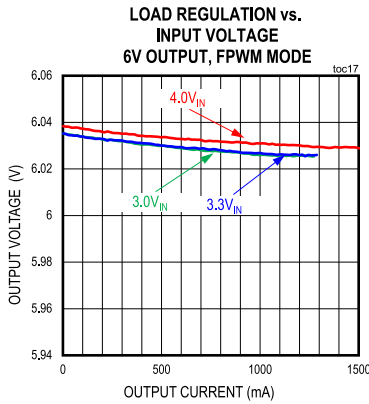

Typical Operating Characteristics (continued)

(T_A = 25°C)

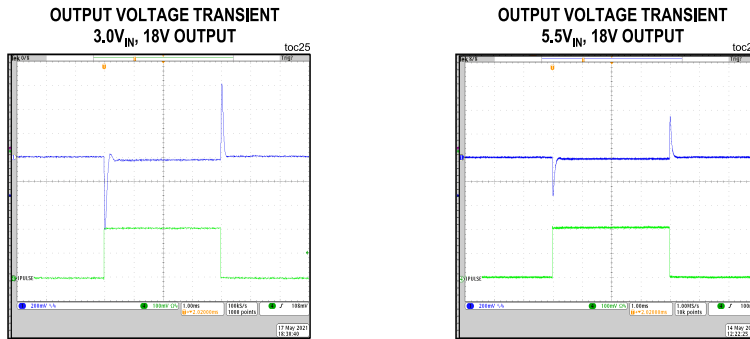

Pin Configuration

MAX20474

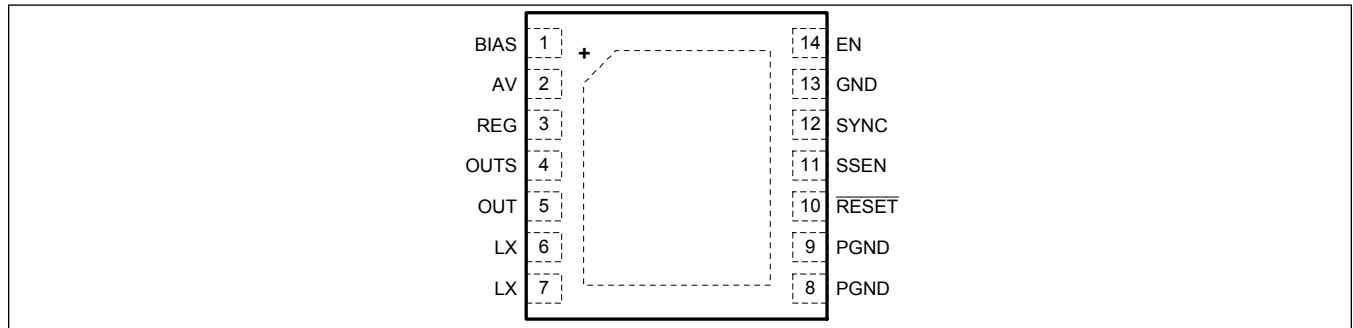

Pin Description

PIN	NAME	FUNCTION
1	BIAS	BIAS LDO Output. Connect a 2.2μF ceramic capacitor to from BIAS to GND.
2	AV	Analog Power Input Supply. Connect a 0.1μF ceramic capacitor from AV to GND.
3	REG	LDO Output. Connect a capacitor from REG to OUT. See REG Pin Considerations for required value.
4	OUTS	Output Voltage Feedback Pin. Connect this pin to the output capacitor for part numbers with fixed output voltage or through a resistor divider for the adjustable output version.
5	OUT	Output Voltage.
6,7	LX	Inductor Connection. Connect LX to the switched side of the inductor.
8,9	PGND	Power Ground.
10	RESET	Open-Drain RESET Output. To obtain a logic signal, pull-up RESET with an external resistor.
11	SSEN	Spread Spectrum Enable. Connect to input supply to enable spread spectrum or to ground to disable.

Pin Description (continued)

PIN	NAME	FUNCTION
12	SYNC	SYNC Input. Connect SYNC to GND or leave unconnected to enable skip-mode operation under light loads. Connect SYNC to AV or an external clock to enable fixed-frequency forced-PWM-mode operation.
13	GND	Ground. Connect all ground pins to the EP.
14	EN	Active-High Enable. Drive EN HIGH for normal operation.
-	EP	Exposed Pad. Connect the exposed pad to ground. Connecting the exposed pad to ground does not remove the requirement for proper ground connections to PGND. The exposed pad is attached with epoxy to the substrate of the die, making it an excellent path to remove heat from the IC.

Functional Diagrams

Internal Block Diagram

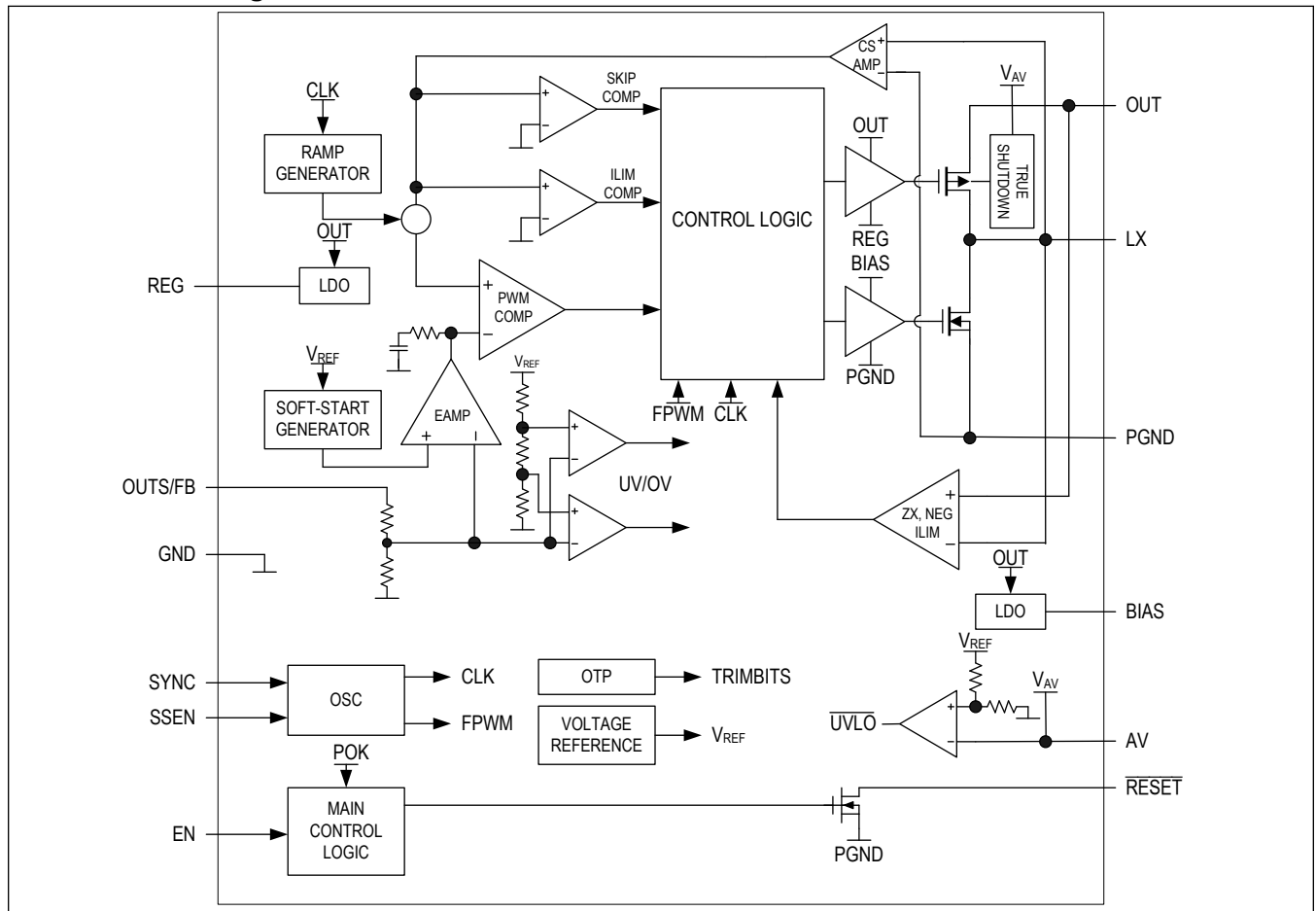

Detailed Description

The MAX20474 is a high-efficiency, 6V to 18V output synchronous DC-DC boost converter that boosts the input supply of 3.0V to 5.5V to an output voltage of 6V to 18V. The boost converter has true shutdown so the output voltage is 0V when off. The boost converter achieves $\pm 1.5\%$ output error over load, line, and temperature ranges for the fixed output voltage options.

The device features a 2.2MHz fixed-frequency PWM mode for better noise immunity and load transient response, and a pulse-frequency modulation (SKIP) mode for increased efficiency during light-load operation. The 2.2MHz frequency operation allows for the use of all ceramic capacitors and minimizes external components. The programmable spread-spectrum frequency modulation minimizes radiated electromagnetic emissions. The spread modulation can be factory set to pseudo random. Integrated low RDSON switches improve efficiency at heavy loads and make the layout a much simpler task with respect to discrete solutions.

The MAX20474 contains high accuracy factory set OV/UV thresholds for each output which are mapped to the $\overline{\text{RESET}}$ pin. There are diagnostics on the $\overline{\text{RESET}}$ and OUT pins to guarantee high reliability and fail-safe operation.

In light-load applications, a logic input (SYNC) allows the devices to operate either in SKIP mode for reduced current consumption or fixed-frequency, forced-PWM mode to eliminate frequency variation and help minimize EMI. Protection features include cycle-by-cycle current limit and thermal shutdown with automatic recovery.

Enable Input (EN)

The enable control inputs (EN) activate the device channel from their low-power shutdown state. EN has an input threshold of 1V (typ) with a hysteresis of 80mV (typ). When an enable input goes high, the associated output voltage ramps up with the programmed soft-start time.

RESET Output

The device features individual open-drain reset outputs for each output that asserts low when the corresponding output voltage is outside of the UV/OV window. $\overline{\text{RESET}}$ remains asserted for a fixed timeout period after the output rises up to its regulated voltage. The fixed timeout period is factory programmable between 0.5ms, 3.7ms, 7.4ms, or 14.9ms. Contact the factory for a preprogrammed timeout period. To obtain a logic signal, place a resistor pull-up between $\overline{\text{RESET}}$ pins to the system I/O voltage.

Internal Oscillator

The device has a spread spectrum oscillator which varies the internal operating frequency up by $\pm 3\%$ relative to the internally generated operating frequency of 2.2MHz (typ). This function does not apply to externally applied oscillation frequency. The spread frequency generated is pseudo-random with a repeat rate well below the audio band.

Synchronization (SYNC)

The device has an on-chip oscillator that provides a fixed switching frequency of 2.2MHz. Depending on the condition of SYNC, two operation modes exist.

Operation Mode 1, SKIP: If SYNC is unconnected or at GND, the device will operate in the highly efficient pulse-skipping mode if the load current is below the SKIP mode current threshold.

Operation Mode 2, FPWM: If SYNC is at AV or has an applied frequency from an external source, then the device is in forced PWM mode.

SYNC may be switched to SKIP or FPWM at any time during operation. An external clock may also be applied or disabled at any time during operation as well. However, to minimize overshoots and undershoots affecting downstream circuits during on-the-fly mode transitions with SYNC, it is recommended to disable the MAX20474 first then transition SYNC to SKIP or FPWM, or enable or disable an external clock.

Soft-Start

MAX20474 includes a fixed soft-start of 1.9ms. Soft-start time limits start-up inrush current by forcing the output voltage to ramp up towards its regulation point.

Current Limit / Short-Circuit Protection

The device features current limit that protects the device against short-circuit and overload conditions at the output. In the event of a short-circuit or overload condition, the high-side MOSFET remains on until the inductor current reaches the high-side MOSFET's current-limit threshold. The converter then turns on the low-side MOSFET to allow the inductor current to ramp down. Once the inductor current crosses below the low-side MOSFET current-limit threshold, the converter turns on the high-side MOSFET again. This cycle repeats until the short or overload condition is removed.

PWM/SKIP Modes

The device features an input (SYNC) that puts the converter either in SKIP mode or forced PWM mode of operation. See the [Pin Description](#) section for more details. In PWM mode of operation, the converter switches at a constant frequency with variable on-time. In SKIP mode of operation, the converter's switching frequency is load dependent until the output load reaches a certain threshold. At higher load current, the switching frequency does not change and the operating mode is similar to the PWM mode. SKIP mode helps improve efficiency in light load applications by allowing the converter to turn on the high side switch only when the output voltage falls below a set threshold. As such, the converter does not switch MOSFETs on and off as often as is the case in the PWM mode. Consequently, the gate charge and switching losses are much lower in SKIP mode.

Over-Temperature Protection

Thermal overload protection limits the total power dissipation in the MAX20474. When the junction temperature exceeds 165°C (typ), an internal thermal sensor shuts down the internal bias regulator and the step-down controller, allowing the IC to cool. The thermal sensor turns on the IC again after the junction temperature cools by 15°C.

OUTS Pin Considerations

The OUTS pin of the MAX20474 does not protect against open circuit conditions. If the OUTS pin is open, the high-side MOSFET of the output stage will attempt to regulate the output voltage leading to damage. Careful consideration should be taken for adjustable output voltage options where open circuits can occur due to poor connections of the feedback resistors (e.g., cold solder joints). For fixed output voltage options, the OUTS pin is shorted to the OUT pin therefore only PCB pad or trace damage can be considered for an open condition.

BIAS Pin Considerations

The BIAS pin provides a external connection to a bypass capacitor for the internal BIAS LDO. It is not recommended for any other external circuitry to connect to the BIAS pin as the BIAS LDO does not source current.

REG Pin Considerations

The MAX20474 does not implement self-protection when the REG pin is shorted to ground; irreparable damage can occur. The REG pin also requires additional protection when the OUT pin is shorted to ground. When the application use case requires short circuit protection, a capacitor from the REG pin to ground is required. The following table outlines the conditions and capacitance values necessary for REG pin protection during OUT pin shorts to ground for either variant (e.g., Fixed Output Voltage or Adjustable Output Voltage).

Table 1. REG Pin Capacitance Recommendations for Short Circuit Protection

OUTPUT VOLTAGE	CAPACITANCE FROM OUT TO REG	CAPACITANCE FROM REG TO GND	NOTES
<8V	220nF	330nF	X7R, 50V, ±10% CGA3E3X7R1H334K080AB
≥8V	220nF	220nF	X7R, 50V, ±10% CGA3E3X7R1H224K080AB
6V to 18V	330nF	Open	When short protection is not required

Applications Information

Input Capacitor

The input filter capacitor reduces peak currents drawn from the power source and reduces noise and voltage ripple on the input caused by the circuit's switching. A 2.2μF X7R ceramic capacitor is recommended for the AV pin.

Inductor Selection

Choosing an inductor value for the MAX20474 is a trade off between inductor size and type, inductor ripple requirements, and the input current limit.

The inductor type may be a ferrite core or a soft-saturation core. For a ferrite core, the saturation current should be greater than the maximum current limit. For a soft-saturation core, the saturation current can be less than the maximum current limit as long as the inductance at the maximum current limit is greater than 50% of the nominal inductance.

Equation 1 is the ideal, canonical equation used to calculate the peak-to-peak ripple in a boost converter.

$$\text{EQ1} : 2 \Delta i_L = \left(\frac{V_{IN}}{L \cdot f_{SW}} \right) \cdot \left(1 - \frac{V_{IN}}{V_{OUT}} \right)$$

where $2 \Delta i_L$ is the peak-to-peak inductor ripple chosen to meet system requirements.

Equation 1 is rearranged to calculate the required inductor value to meet the desired ripple amplitude:

$$\text{EQ2} : L = \left(\frac{V_{IN}}{2 \Delta i_L \cdot f_{SW}} \right) \cdot \left(1 - \frac{V_{IN}}{V_{OUT}} \right)$$

where $2 \Delta i_L$ is typically limited to 30% of the maximum load current.

Equation 2 illustrates that a smaller inductance value will yield higher ripple current. Care must be taken regarding the ripple amplitude as the MAX20474 implements peak current limit on the input. Therefore, the sum of the peak current and maximum load current should not exceed the input current limit. Equation 3 is used to calculate the peak current in the inductor.

$$\text{EQ3} : I_{PEAK} = I_{OUT} + \frac{\Delta i_L}{2}$$

A 1μH inductor is recommended as the nominal inductance value across the input (3V to 5.5V) and output voltages (6V to 18V) for the MAX20474.

Boost Output Capacitor

The MAX20474 is designed to be stable with low ESR ceramic capacitors. Other capacitor types are not recommended as the ESR zero can affect stability of the device. The following output capacitor calculations are guidelines based on nominal conditions. The phase margin must be measured on the final circuit to verify that proper stability is achieved.

$$C_{OUT_{MIN}} = \frac{110 \mu s \cdot A}{V_{OUT}}$$

$$C_{OUT_{NOM}} = \frac{220 \mu s \cdot A}{V_{OUT}}$$

$$C_{OUT_{MAX}} = 2.5 \cdot C_{NOM}$$

External Feedback Resistors

The MAX20474 is available in a fixed voltage output through factory trim and an adjustable voltage output version. The output voltage range for both versions is 6V to 18V. For a desirable output voltage for the adjustable option, the following equation is necessary to calculate the external feedback resistors:

$$R_{HIGH} = R_{LOW} \left[\frac{V_{OUT}}{V_{REF}} - 1 \right]$$

where

$V_{REF} = 812mV$, typical per the Electrical Characteristics table

The parallel combination of R_{HIGH} and R_{LOW} should be $\leq 30k\Omega$ to help reduce errors due to PCB contamination. It is important for the fixed output variant of the MAX20474 that V_{OUTS} is shorted to V_{OUT} for proper operation or damage can occur to the device.

Typical Application Circuits

Applications Circuit - Fixed Output

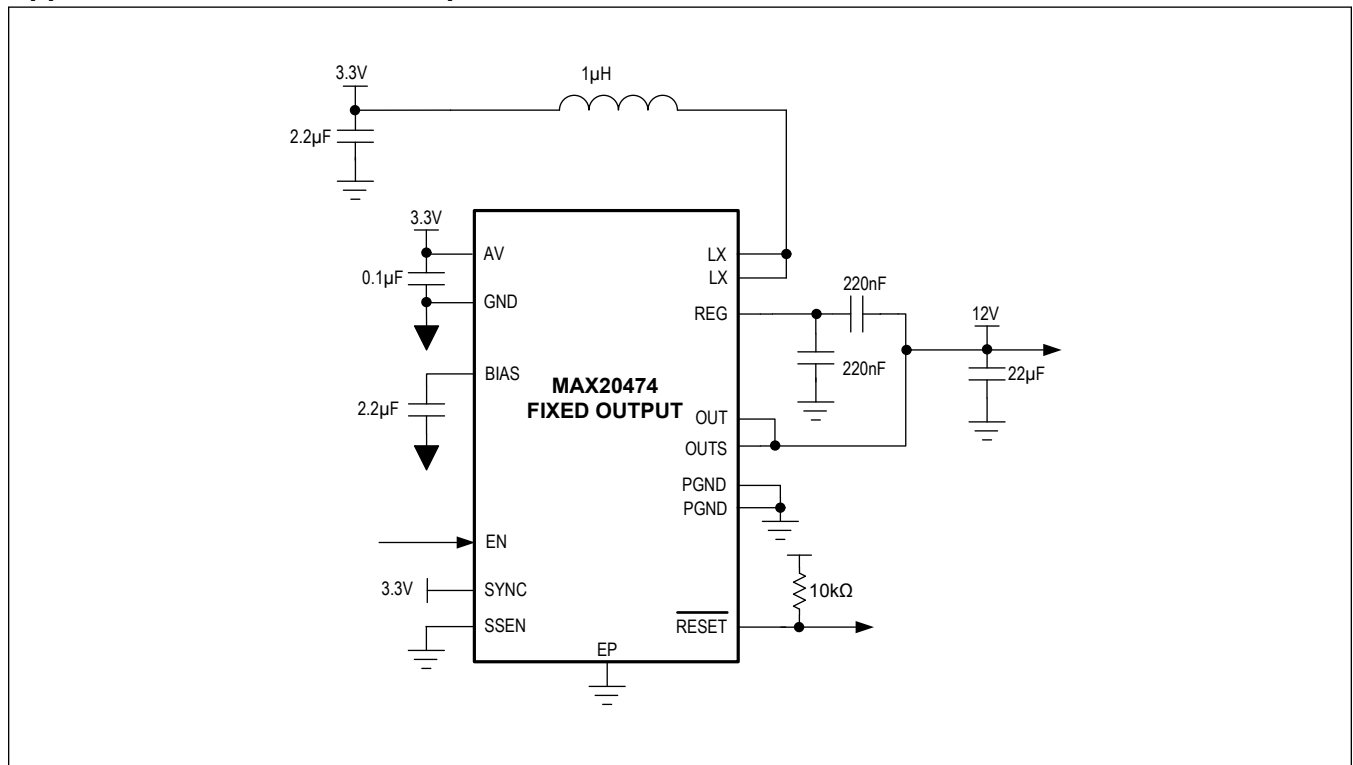

Typical Application Circuits (continued)

Typical Applications Circuit - Adjustable 12V Output

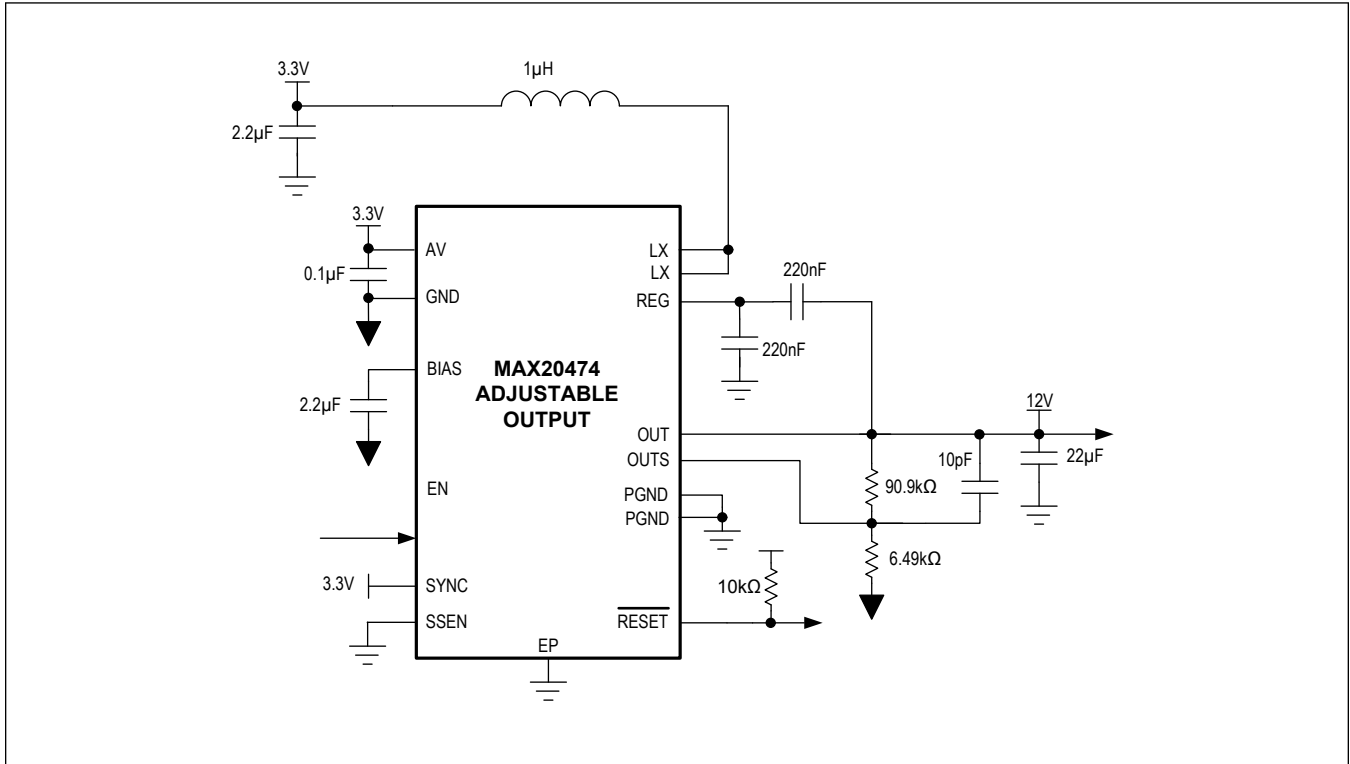

Ordering Information

PART	OUTPUT VOLTAGE	INPUT CURRENT LIMIT	TEMP RANGE
MAX20474ATDA/V+	Adjustable	4A	-40°C to +125°C
MAX20474ATDB/V+*	12V	4A	-40°C to +125°C

*Future product—contact factory for availability.

+Denotes a lead(Pb)-free/RoHS-compliant package.

T = Tape and reel.

/V Denotes an automotive qualified part.

MAX20474

3.0V to 5.5V Input, 6V to 18V Output, Synchronous
Boost Converter

Revision History

REVISION NUMBER	REVISION DATE	DESCRIPTION	PAGES CHANGED
0	7/21	Release for Market Intro	—

For pricing, delivery, and ordering information, please visit Maxim Integrated's online storefront at <https://www.maximintegrated.com/en/storefront/storefront.html>.

Maxim Integrated cannot assume responsibility for use of any circuitry other than circuitry entirely embodied in a Maxim Integrated product. No circuit patent licenses are implied. Maxim Integrated reserves the right to change the circuitry and specifications without notice at any time. The parametric values (min and max limits) shown in the Electrical Characteristics table are guaranteed. Other parametric values quoted in this data sheet are provided for guidance.