

Air Actuated Hydraulic Hand Jacks

Operating Instructions & parts Manual

Model Number	Capacity
QYL12	12TON
QYL20	20TON
QYL20D	20TON
QYL32	32TON
QYL50	50TON

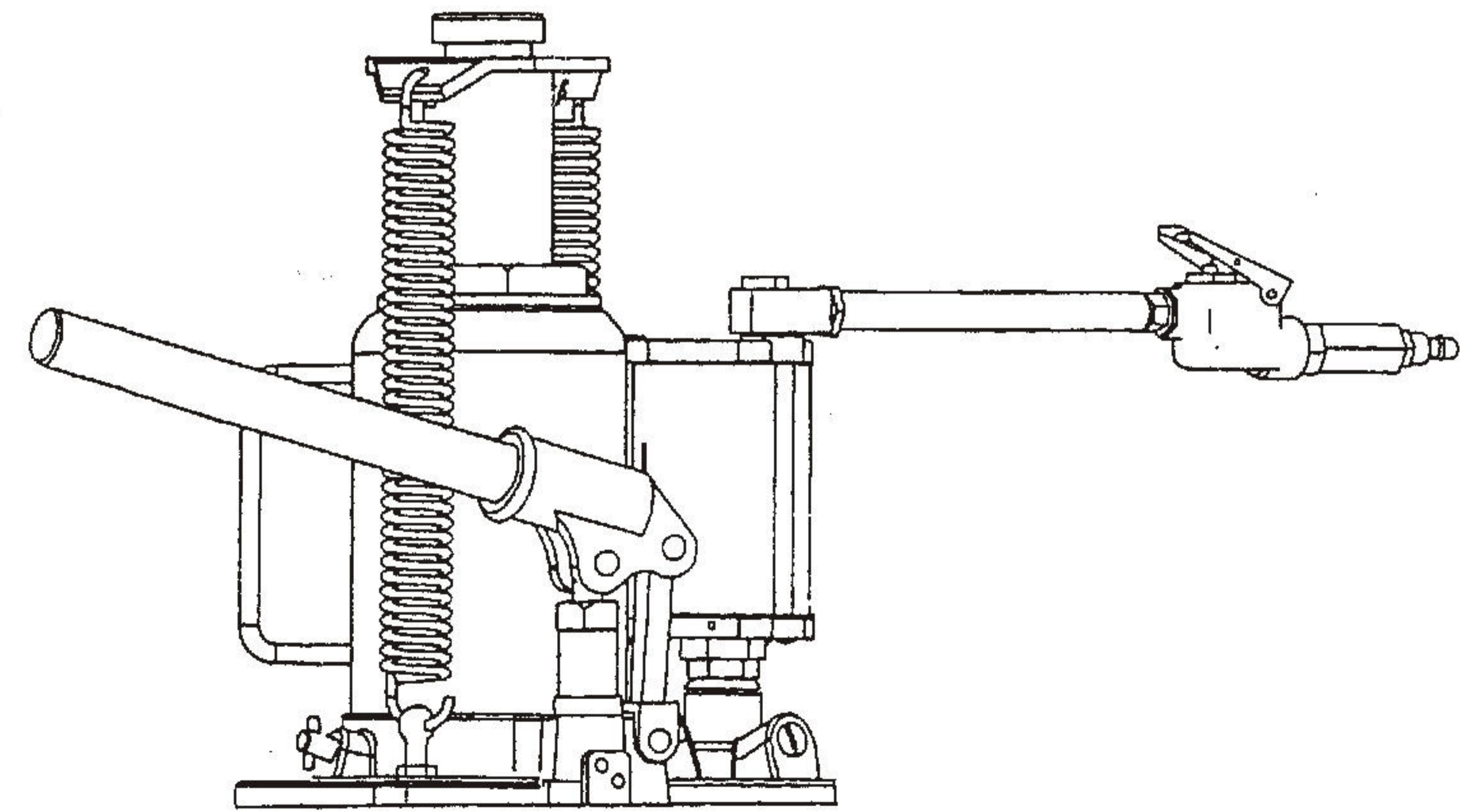

OPERATION

Lifting

1. Assemble 2 pc. Handle, ensure that spring clips align with slots.
2. Secure the load to prevent inadvertent shifting and movement.
3. Position the jack near desired lift point.
4. Close the release valve by turning it clockwise until it is firmly closed.

CAUTION: USE THE HANDLE PROVIDED WITH THIS PRODUCT OR AN AUTHORIZED REPLACEMENT HANDLE TO ENSURE PROPER RELEASE VALVE OPERATION. DO NOT USE AN EXTENDER ON THE AIR HOSE NOR THE OPERATING HANDLE. WHEN USING TO LIFT VEHICLE, LIFT ONLY ON THE MANUFACTURER'S RECOMMENDED LIFT POINT AND IN ACCORDANCE WITH THE PUBLISHED GUIDELINES IN YOUR VEHICLE OWNERS MANUAL. ALWAYS USE JACK STANDS TO SUPPORT THE LOAD IMMEDIATELY AFTER LIFTING.

5. Insert and secure handle into handle sleeve. Pump handle or squeeze the lift control valve until saddle contacts load. To end air operation, simply release the grip on the lift control valve. NEVER WIRE, CLAMP OR OTHERWISE DISABLE THE THE LIFT CONTROL VALVE TO FUNCTION BY ANY MEANS OTHER THAN BY USING THE OPERATOR'S HAND.
6. Raise load to desired height, then immediately transfer the load to appropriately-rated support devices such as jack stands.



THIS IS A LIFTING DEVICE ONLY. IT IS DESIGNED TO LIFT PART OF THE TOTAL VEHICLE (ONE WHEEL OR AXLE). ALWAYS WEAR SAFETY GLASSES WHEN USING THIS EQUIPMENT. CENTER LOAD ON SADDLE BEFORE LIFTING. NEVER WORK ON, UNDER OR AROUND LOAD UNTIL IT IS PROPERLY SUPPORTED. TRANSFER THE LOAD IMMEDIATELY TO APPROPRIATE RATED JACK STANDS. DO NOT USE THIS PRODUCT FOR ANY PURPOSE OTHER THAN THAT FOR WHICH IT WAS INTENDED. IT IS OWNER'S RESPONSIBILITY TO KEEP LABELS AND INSTRUCTIONAL MATERIAL LEGIBLE AND AVAILABLE. REPLACEMENT LABELS AND MANUALS ARE AVAILABLE FROM THE MANUFACTURER. FAILURE TO HEED THESE AND ALL OTHER WARNINGS PERTAINING TO THIS PRODUCT CAN RESULT IN SUDDEN LOSS OF LIFTED LOAD RESULTING IN DEATH, PERSONAL INJURY OR PROPERTY DAMAGE.

Lowering

1. Raise load enough to carefully remove jack stands.
2. Insert handle onto release valve and slowly turn handle counterclockwise, but no more than 1/2 turn. If load fails to lower, carefully transfer the

load to another lifting device and jack stands. Carefully remove affected jack, and then the jack stands. Lower the load, again by slowly turning the release valve no more than 1/2 turn.



BE SURE ALL TOOLS AND PERSONNEL ARE CLEAR BEFORE LOWERING LOAD. DANGEROUS DYNAMIC SHOCK LOADS ARE CREATED BY QUICKLY OPENING AND CLOSING THE RELEASE VALVE AS THE LOAD IS BEING LOWERED. THE RESULTING OVERLOAD MAY CAUSE HYDRAULIC SYSTEM FAILURE WHICH COULD CAUSE SEVERE PERSONAL INJURY AND/OR PROPERTY DAMAGE.

3. After removing jack from under the load, push ram and handle sleeve down to reduce exposure to rust and contamination.

MAINTENANCE

Important: Use only a good grade hydraulic jack oil. Avoid mixing different types of fluid and NEVER use brake fluid, turbine oil, transmission fluid, motor oil or glycerin. Improper fluid can cause premature failure of the jack and the potential for sudden and immediate loss of load.

Adding oil

1. With saddle fully lowered and pump piston fully depressed, set jack in its upright, level position. Remove oil filler plug.
2. Fill until oil is level with the filler plug hole, re-install oil filler plug.

Changing oil

For best performance and longest life, replace the complete fluid supply at least once per year.

1. With saddle fully lowered and pump piston fully depressed, remove the oil filler plug.
2. Lay the jack, on its side and drain the fluid into a suitable container.

Note: Dispose of hydraulic fluid in accordance with local regulations.

3. Fill with good quality jack oil. Reinstall oil filler Plug. We recommend Mobil DTE 13 or equivalent.

AIR MOTOR

PARTS LIST

NO.	PARTS NAME	QTY
1-1	TUBE CONNECTOR	1
1-2	"O" RING 10 x 1.8	2
1-3	REMOVABLE BASE	1
1-4	SPLIT WASHER	1
2	HEX-SOCKET SCREW	3
3	COVER	1
4	WASHER	2
5	AIR PUMP BODY	1
6	SPRING WASHER	3
7	SEAL	2
8	"O" RING 63.5 x 3.55	2
9	SQUARE RING	1
10	PISTON	1
11	NUT M5	1
12	BLOCK	1
13	PLUNGER	1
14	SPRING	1
15	NUT	1
16	PACKING GUIDE	1
17	NL RETAINER	1
18	"Y" SEAL	1
19	COVER	1
20	ADJUSTING NUT	1
21	PLUNGER COVER	1

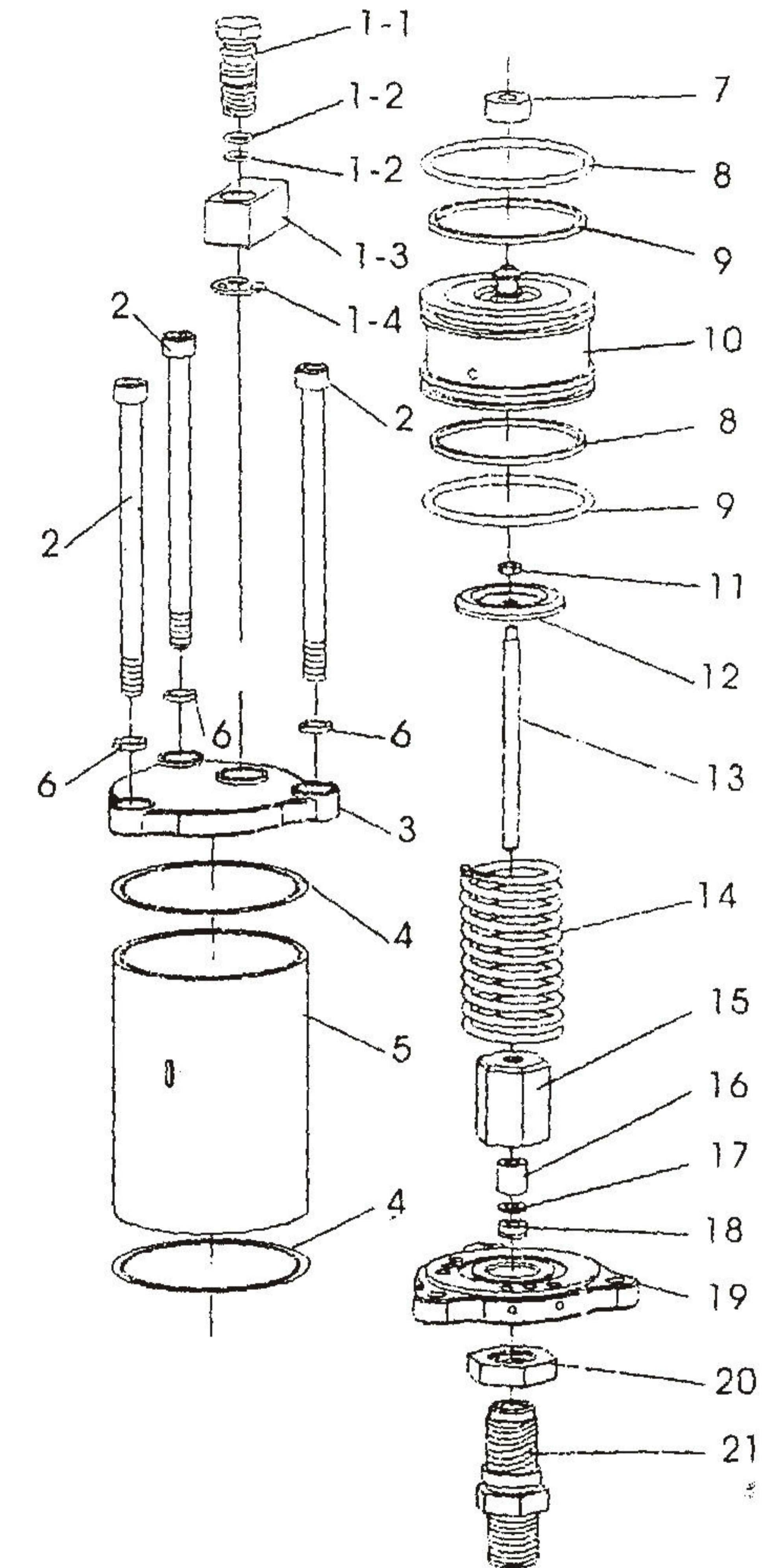

NO.	DESCRIPTION	QTY		NO.	DESCRIPTION	QTY	
		QYL12D QYL20D	QYL20W			QYL12D QYL20D	QYL20W
1.1	hose connector	1	1	19	release valve seal	1	1
1.2	connecting nut	1	1	20	steel ball 6.35	1	1
1.3	air filter	1	1	21	pin	1	1
1.4	"O" ring 18×24	1	1	22	valve spring	2	2
1.5	connector	1	1	23	filler plug	1	1
1.6	valve body	1	1	24	screw	2	2
1.7	spring	1	1	25	plug screw	1	2
1.8	packing	1	1	26	plung washer	1	2
1.9	throttle	1	1	27	overload valve screw	1	2
1.10	"O" ring 3×1.6	1	1	28	safety valve spring	1	2
1.11	"O" ring 18×2.4	1	1	29	overload tapering valve	1	2
1.12	nut	1	1	30	filter net	2	2
1.13	lever	1	1	31	spring wasehr 8	2	2
1.14	lever rin	1	1	32	nut 8	2	2
1.15	hose connector	1	1	33	bolt M8×35	2	2
1.16	hose band	2	2	34	base	1	1
2	air hose	1	1	35	plug screw	4	4
3	connector	1	1	36	cylinder bottom seal	1	1
4	air pump	1	1	37	reservoir	1	1
5	handle upper	1	1	38	packing	1	1
6	handle lower	1	1	39	cylinder	1	1
7	plunger	1	1	40	steel ball retainer	2	2
8	shaft pin	3	3	41	cylinder top seal	1	1
9	cotter pin	3	3	42	"O" ring	1	1
10	pump plunger	1	1	43	top nut	1	1
11	pump plunger retainer	1	1	44	extension screw	1	1
12	"O" ring	1	1	45	"O" ring	1	1
13	dust proof ring	1	1	46	"O" ring returner	1	1
14	pump reservoir	1	1	47	ram header	1	1
15	copper washer	1	1	48	ram	1	1
16	steel ball 6	6	6	49	spring	2	2
17	plunger comvecting rod	1	1	50	spring plate	2	2
18	release valve screw	1	1				

Lubrication

1. A coating of light lubricating oil to pivot points, axles and hinges will help to prevent rust and assure that wheels, casters and pump assemblies move freely.
2. Periodically check the pump piston and ram for

Signs of rust or corrosion. Clean as needed and wipe with an oily cloth.

NEVER USE SANDPAPER OR ABRASIVE MATERIAL ON THESE SURFACES!

3. When not in use, store the jack with pump piston and ram fully retracted.

TROUBLESHOOTING

Symptom	Possible Causes	Corrective Action
Jack will not lift load	Release valve not tightly closed Overload condition Air supply inadequate	Ensure release valve tightly closed Remedy overload condition Ensure adequate air supply
Jack bleeds off after lift	Release valve not tightly closed Overload condition Hydraulic unit malfunction	Ensure release valve tightly closed Remedy overload condition Contact seller
Jack will not lower after unloading	Reservoir overfilled Linkages binding	Drain fluid to proper level Clean and lubricate moving parts
Poor lift performance	Fluid level low Air trapped in system	Ensure proper fluid level With ram fully retracted, remove oil filler plug to let pressurized air escape, reinstall oil filler plug
Will not lift to full extension	Fluid level low	Ensure proper fluid level

Model	Lifting Capacity (TON)	Min Altitude (mm)	Lifting Altitude (mm)	Regulating Altitude (mm)	Air Pressure Range (MPA)	Net Weight (kg)
QYL12	12T	250	165	80	0.8-0.95	10
QYL20	20T	260	170	80	0.8-0.95	17
QYL20D	20T	210	100	80	0.8-0.95	15
QYL22	22T	225+25	130	80	0.8-0.95	36
QYL32	32T	250+25	160	/	0.8-1	21
QYL50	50T	270+25	160	/	0.8-1	34

QYL12

QYL20

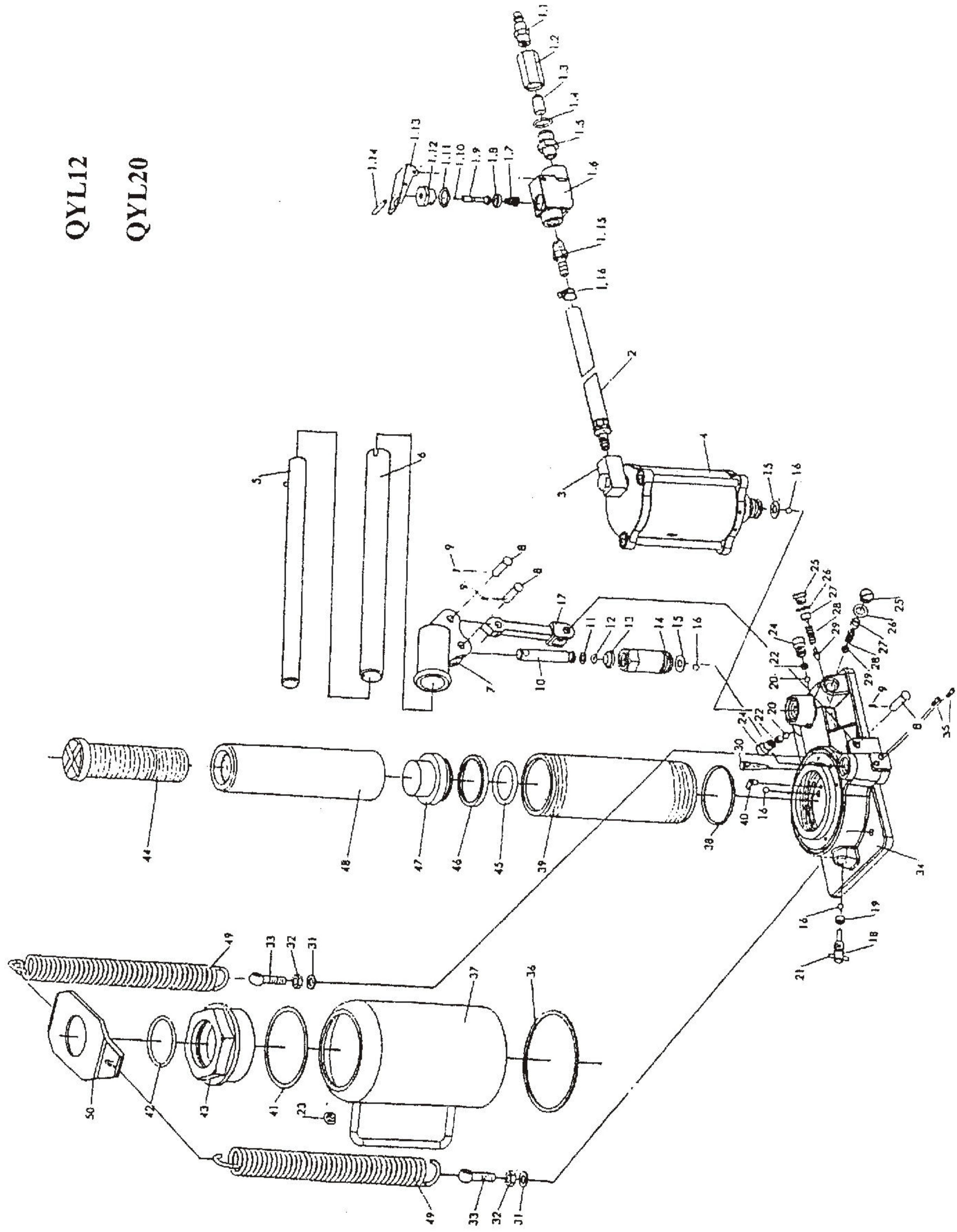

QYL20D

