

SPECIFICATION

FOR

BRITISH POWER SUPPLY CORDSET (PB FR)

CORD : H05VV-F 3X1.00mm² PVC LEAD FREE

CUSTOMER : VPE/RS COMPONENTS

CUSTOMER'S PART No. : 1469110 (V-NOVUS UK-C13 5M)

VOLEX'S SPEC. REF. No. : 173018

ISSUE No. : 008

DATE : 18TH JUNE 2021

CUSTOMER APPROVED :

APPROVED BY :	
SIGNATURE :	
APPROVED DATE :	
No. OF PAGES :	



AMENDMENT RECORD

REF. No.	DESCRIPTION OF CHANGES	DATE
173018	(1) FIRST SUBMISSION.	24/10/17
(VPE10-057-17)		
ISSUE : 001		
173018	(1) CHANGE CUSTOMER P/N FM. '146911Ø' TO	27/11/17
(EVPE11-080-17)	'146911Ø (V-NOVUS UK-C13 5M)' ON COVER PAGE &	
ISSUE : 002	ASSEMBLY DWG. PAGE.	
	(2) CHANGE CABLE MARKING FM. 'INK MARK' TO 'INDENTED'	
	& REMOVE ITEM No. '1210365' FM. ASSEMBLY DWG. PAGE.	
173018	(1) ADD IN PE BAG '904036' & LABEL 'VL-0538'	25/01/18
(VPE01-078-18)	AS SHOWN ON ASSEMBLY DWG. PAGE	
ISSUE : 003	(2) ADD IN NOTE 5 AS SHOWN ON ASSEMBLY DWG. PAGE.	
	(3) ADD IN LABEL DWG. PAGE.	
	(4) UPDATE PLUG SPEC PAGES.	
173018	(1) CHANGE LABEL FM. 'VL-0538' TO 'L-T383' & REMOVE	14/02/18
(EVPE02-113-18)	NOTE 5 FROM ASSEMBLY DWG. PAGE.	
ISSUE : 004	(2) CHANGE LABEL DWG. PAGES.	
173018	(1) ADD IN CABLE ITEM NO. '121131' ON ASSEMBLY DWG. PAGE.	01/02/19
(EVPE01-081-19)	(2) CHANGE LABEL WITH CE LOGO & ITS ITEM NO. FM.	
ISSUE : 005	'L-T383' TO 'L-T430' ON ASSEMBLY DWG. PAGE.	
	(3) CHANGE LABEL DWG. PAGES.	
	(4) UPDATE PLUG & CONNECTOR SPEC PAGES.	
173018	(1) CHANGE LABEL ITEM NO. FM. 'L-T430' TO '6103451'	14/03/19
(VPE03-014-19)	ON ASSEMBLY DWG. PAGE.	
ISSUE : 006	(2) CHANGE LABEL DWG. PAGES.	
173018	(1) REMOVE FUSE ITEM NO. 6210005 ON ASSEMBLY DWG. PAGE.	28/11/19
(VPE11-158-19)	(2) UPDATE DESCRIPTION OF 6103451 ON ASSEMBLY DWG. PAGE.	
ISSUE : 007	(3) UPDATE LABEL DWG. PAGE.	
	(4) UPDATE PLUG & CONN. SPEC PAGES.	
	(5) UPDATE FUSE DWG. PAGES.	
173018	(1) CHANGE ITEM NO. FM. '6103451' TO 'L-Z015' ON ASSEMBLY DWG. PAGE.	18/06/21
(EVPE06-048-21)	(2) UPDATE LABEL PAGES.	
ISSUE : 008	(3) UPDATE PLUG & CONN. SPEC PAGES.	

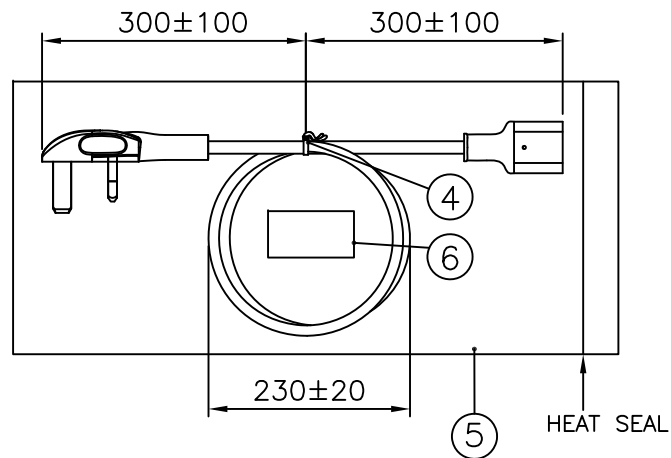
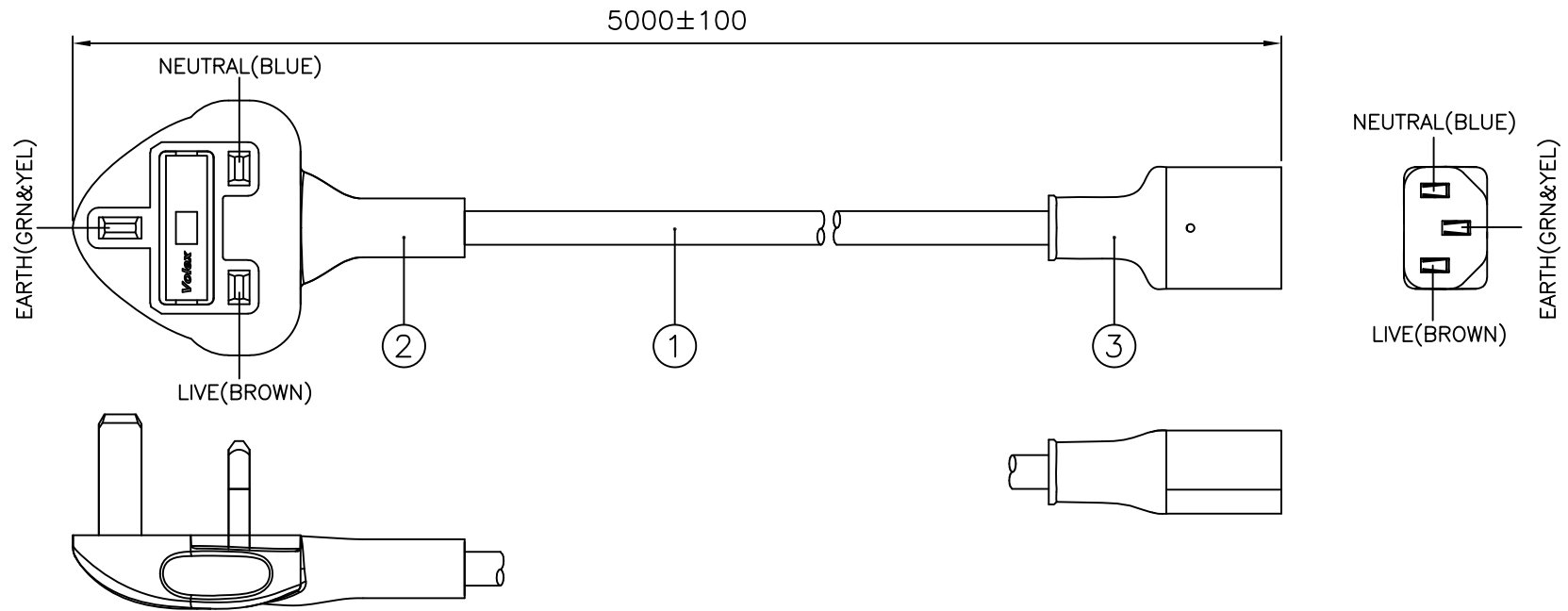

6	RS LABEL 45X25MM WITH CE & UKCA & WEEE LOGO.	L-Z015	1
5	BAG PE 356X508X0.05	904036	1
4	PE TIE BLK(REEL)	6310101	1X152MM
3	IP40G NL792B BLK	4100017	-
	MOLDED CONNECTOR VNC13S (10A 250V)	VNC13S-V	1
2	FUSE 10A (CAP WITH NICKEL PLATING)	6210013	1
	IP40G NL792B BLK	4100017	-
2	MOLDED PLUG VNUK13A3 (10A 250V)	VNUK13A3-V	1
1	H05W-F 3X1.00 BLK LF(INDENT)	1211311	1
S/N	DESCRIPTION	ITEM NUMBER	QTY

APPROVED SOURCE FOR CABLE

1. BAO HING(SHENZHEN).

NOTE :

1. ALL DIMENSIONS IN mm.
2. THE CORD SHALL COMPLY WITH EN 50525-2-11.
3. THE MOLDED PLUG SHALL COMPLY WITH BS 1363-1.
4. THE MOLDED CONNECTOR SHALL COMPLY WITH IEC 60320-1 OR EN 60320-1.
5. THIS PART TO BE MANUFACTURED IN ZHONGSHAN (CHINA) ONLY.

TITLE :		BRITISH POWER SUPPLY CORDSET (PB FR)		SCALE :	N.T.S.
CUSTOMER :		VPE/RS COMPONENTS		PAGE :	1/1
CUSTOMER PART NUMBER :		1469110 (V-NOVUS UK-C13 5M)		ISSUE	
Reference Number :		173018 (EVPE06-048-21)		008	
SALES :	QA :	ENGRG :	CHECKED BY :	DRAWN BY :	
		<i>Camon</i>	<i>Wang</i>	FUWANG	
Date :	Date :	Date :	Date :	Date :	
		28/06/21	25/06/21	18/06/21	

DRAWING NUMBER : REVISION :

L-Z015

1

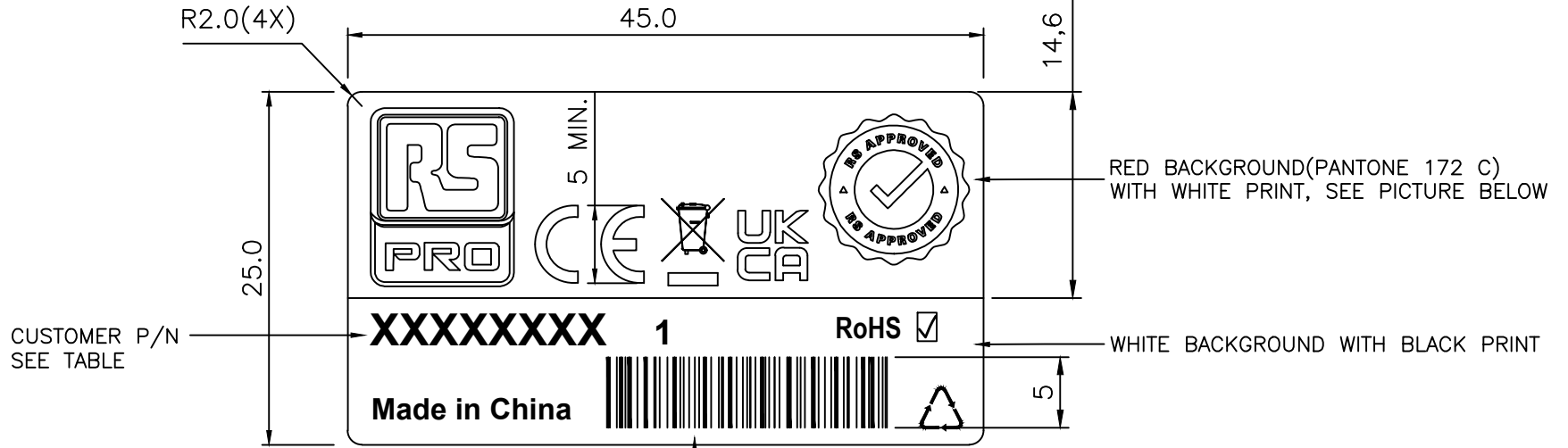

CUSTOMER P/N
SEE TABLE

RED BACKGROUND(PANTONE 172 C)
WITH WHITE PRINT, SEE PICTURE BELOW

WHITE BACKGROUND WITH BLACK PRINT

BARCODE: CODE 128A, SCAN SHOW CUSTOMER P/N



PICTURE FOR COLOUR PRINT

DRAWN : ALICE	REV	IMM/ECR	BY	DATE	REV	IMM/ECR	BY	DATE	TITLE : RS LABEL 45X25MM WITH CE & UKCA & WEEE LOGO
RELEASED : 22/01/19	1	ECN006-21	Eamon	11/06/21					
SIGN	DATE								ITEM NO.:
CHECKED :									SEE TABLE
APPROVED :									FILENAME : \\LABEL\PREPRINTED\L-0654
									SCALE : 2 : 1
									PROJ. : THIRD ANGLE
									PAGE : 1/2

DRAWING NUMBER : REVISION :

L-Z015

1

TABLE

CUSTOMER P/N	ITEM NO.	CUSTOMER P/N	ITEM NO.	CUSTOMER P/N	ITEM NO.	CUSTOMER P/N	ITEM NO.
1247409	6103431-XXXX	9092193	6103524-XXXX	311-9359-0000	6103559-XXXX		
1468803	6103441-XXXX	445 740	6103528-XXXX	1230935	6103686-XXXX		
1468804	6103442-XXXX	449 297	6103529-XXXX	1230938	6103687-XXXX		
1469102	6103443-XXXX	449 326	6103530-XXXX	1230951	6103688-XXXX		
1469103	6103444-XXXX	815 846	6103531-XXXX	1230952	6103689-XXXX		
1469104	6103445-XXXX	268 2610	6103532-XXXX	1230953	6103690-XXXX		
1469105	6103446-XXXX	311 9315	6103533-XXXX	7316153	6103693-XXXX		
1469106	6103447-XXXX	262 1126 0001	6103535-XXXX	7440922	6103694-XXXX		
1469107	6103448-XXXX	262 1154 0001	6103536-XXXX				
1469108	6103449-XXXX	262 1160 0001	6103537-XXXX				
1469109	6103450-XXXX	262 1176 0001	6103538-XXXX				
1469110	6103451-XXXX	262 1182 0001	6103539-XXXX				
321180	6103473-XXXX	680 3798 0001	6103540-XXXX				
321196	6103474-XXXX	426 373 0001	6103541-XXXX				
321219	6103476-XXXX	426 389 0001	6103542-XXXX				
426424	6103478-XXXX	426 395 0001	6103543-XXXX				
7316166	6103497-XXXX	426 402 0001	6103544-XXXX				
7316175	6103498-XXXX	426 418 0001	6103545-XXXX				
7440925	6103501-XXXX	452 669 0001	6103546-XXXX				
7440929	6103502-XXXX	487 277 0001	6103547-XXXX				
7440931	6103503-XXXX	487 277 0010	6103548-XXXX				
7440941	6103505-XXXX	489 201 0001	6103549-XXXX				
8188909	6103508-XXXX	489 217 0001	6103550-XXXX				
8188912	6103509-XXXX	489 346 0001	6103551-XXXX				
9010753	6103512-XXXX	489 352 0001	6103552-XXXX				
9092156	6103513-XXXX	311-9337-0000	6103558-XXXX				

DRAWN : ALICE	REV	IMM/ECR	BY	DATE	REV	IMM/ECR	BY	DATE	TITLE : RS LABEL 45X25MM WITH CE & UKCA & WEEE LOGO
RELEASED : 22/01/19	1	ECN006-21	Eamon	11/06/21					
SIGN	DATE								ITEM NO.: SEE TABLE
CHECKED :									FILENAME : .\LABEL\PREPRINTED\L-0654
APPROVED :									SCALE : 2 : 1
									PROJ. :  THIRD ANGLE
									PAGE : 2/2

REV.	DESCRIPTION	DATE
I	REMOVE INSULATION COLOR 'BLUE, BROWN, BLACK'	01/09/06
	FM. REV. H PER HD STANDARD.	
J	CHANGE THE COMPLIANCE STANDARD PER SAFETY.	23/12/13
	UPDATE FORMAT AS SHOWN.	

1. PVC FLEXIBLE CORD

1.1 SCOPE

This specification shall be in accordance with EN 50525-2-11. Δ

1.2 CONSTRUCTION

CONDUCTOR	ANNEALED COPPER WIRE
INSULATION	PVC (BLUE, BROWN, GREEN&YELLOW)
JACKET	PVC

ITEM	UNIT	SPEC. VALUE	
TEMPERATURE RATING	°C	70	
RATED VOLTAGE	V	300/500	
NO. OF CORE	NO.	3	
CONDUCTOR NOMINAL AREA	mm ²	1.00	
MIN. AVE. THICKNESS OF INSULATION	mm	0.60	
MIN. THICKNESS AT ANY POINT OF INSULATION	mm	0.44	
MIN. AVE. THICKNESS OF JACKET	mm	0.80	
MIN. THICKNESS AT ANY POINT OF JACKET	mm	0.58	
OVERALL DIAMETER OF JACKET	mm	6.3~8.0	
DIELECTRIC-STRENGTH TEST IMMERSSED IN WATER, 20±5°C FOR MINIMUM 1HR	ON COMPLETED CABLE	—	2000 V FOR 15 MINS (MINIMUM)
	ON CORES	—	1500 V FOR 5 MINS (MINIMUM)
VOLTAGE TEST (D.C)	—	—	2000 Va.c FOR 5 MINS (MINIMUM) OR 5000 Vd.c FOR 5 MINS (MINIMUM)
INSULATION RESISTANCE TEST (70°C)	MΩ km	> 0.01	
CONDUCTOR RESISTANCE TEST (20°C)	Ω /km	≤ 19.5	

TITLE : CABLE SPECIFICATION

EUROPEAN APPROVED POWER SUPPLY CABLE

H05VV-F 3X1.00mm²

SPEC NO. : CS-048EU	APPROVED BY :	CHECKED BY :	DRAWN BY :	REVISION :
	DATE :	DATE :	DATE :	PAGE :
	<i>[Signature]</i>	<i>[Signature]</i>	HONGYAN	J
	30/12/13	27/12/13	23/12/13	1/1

REV.	DESCRIPTION	DATE
A	INITIAL RELEASE.	12/10/02
B	UPDATE MARKING DETAILS.	19/01/05
	UPDATE THE FORMAT AS SHOWN.	
	ADD IN '(EU/SAA/SAB/IEC)' ON THE TITLE.	

CABLE MARKING

BAO HING (SHENZHEN)

▲ :- H05W-F 3G1.0mm² <VDE> KEMA-KEUR +s+s+s
 <ÖVE> CEBEC IEMMEQU SABS 1574 (S) (N) (D) (FI)
 BAOHING GTSA-3 N14586 CE LF

DRAWN	LI XF	19/01/05	FILENAME :	TITLE : CABLE MARKING (EU/SAA/SAB/IEC) ▲
CHECK	<i>W. Li</i>	19/01/05	CABLE MARKING/ BH/H05/H05W-F	
APPR	<i>Changshun</i>	19/01/05	3X1.0 LF- BH	
SCALE	N.T.S.	REV.	B	
REFERENCE :				
H05W-F 3X1.0mm ² LF				

2. PLUG

REV	DESCRIPTION	DATE
AH	ADD IN CATALOG NO. VNBUK13A3B & VNBUK13A2B.	09/05/20
AI	ADD IN CATALOG NO. DS13CA2.	06/11/20

2.1. SCOPE

The plug shall be in accordance with BS 1363 Part 1,
(Specification for up to 13A fused plugs,switched and unswitched socket-outlets)

2.2. CONSTRUCTION

The plug construction shall comply with our catalogue No: MP5004, MP5004A, MP5004AW, MP5004H, MP5004SC, UK13A2,UK13CBA2,UK10SC3, MP5004BS, MP5004V, UK13A3 , MP5004DBS , MP5004D , VPUK13A3, VPUK13A2, DS13CA2, APUK13A2 , APUK13A3, DS13EA2, MFUK13A2, DLUK10S3, VNUK13A3, LSUK13THA3, VNUK13A2, CSUK13A3 , VBUK13A2, VNBUK13A2, VNBUK13A3,VNBUK13A2B , VNBUK13A3B&**DS13CA2**.

2.3. CHARACTERISTICS

NO.	TEST ITEM	DESCRIPTION	ACCEPTANCE CRITERIA
1.	Moisture resistance test	Samples are kept in a humidity cabinet containing air with a relative humidity between 85 to 95% and a temperature of 20°C-30°C for a duration of 48 hours.	No damage
2.	Electric strength test	A voltage of A.C 2000V with a trip current of min. 100mA is applied for 1 min after the moisture resistance test. A voltage of A.C 6000V is also applied between current carrying parts and body for 1 min.	No flashover and breakdown
3.	Insulation resistance test	This test is measured with a D.C 500V for 1 min. after the moisture resistance test.	Min. 5 M Ohm
4.	Flexing test	The sample shall be loaded with a weight of 1kg for 0.75mm ² or less, or 2kg for 1.00mm ² and above and the oscillating member shall be moved backward and forward through an angle of 90°(45° on either side of the vertical) the number of flexing being 10,000.Rated current of the plug is passed.	No damage to the insulation and the breakage of conductor of each core shall not exceed 10%.
5.	Tumbling test	The samples are dropped from a height of 50cm onto a plywood base(10mm thick) for a total of 5000 times.	No damage
6.	Abrasion test	The pin of sample slopes downwards at angle of 10° to the horizontal. The sample is loaded with a force of 4N on the sleeve of the pin. The number of movement is 20,000 and the length of pin subjected to abrasion is approx. 7mm over the insulating sleeve.	No damage

DRAWN:	ROBIN LIU	06/11/20	TITLE : BRITISH PLUG
CHECK:	<i>ROBIN LIU</i>	06/11/20	
APPR:	<i>Feng</i>	06/11/20	
REV:	AI		
REFERENCE:			

NO.	TEST ITEM	DESCRIPTION	ACCEPTANCE CRITERIA
7.	Heat deformation test	The samples are kept for 1 hour in a heating carbinet at temperature of 70±5°C.	no damage and withstand electric strength test.
8.	Ageing test	The samples are kept for 7 days in a heating carbinet at temperature of 70±5°C. It is then put in room temperature for 4 hours.	no damage
9.	Temperature rise test	Rated current of the plug is passed for at least 4 hours. This test is repeated on the same sample after tumbling barrel test.	Rise in temperature for joints shall not exceed 52K while the rest shall not exceed 37K.
10.	Cord-anchorage test	The cord is subjected to a load of 3kg for (1.0mm ² or smaller) or 6kg (the rest) 25 times without jerk. The cord is then subjected to a torque of 0.15Nm (0.5mm ²), 0.2Nm (0.75mm ²), 0.25Nm (1.0mm ²), 0.3Nm (1.25mm ²), 0.35Nm (1.5mm ²) for 1 min.	Shall withstand a voltage of 3750±75V for 1 min., between each conductor and cord shall not been displaced by more than 2mm.
11.	Pressure test	A force of 20N is applied on the sample for 1 hour at a temperature of 70±5°C.	No damage and shall withstand electric strength and insulation resistance test. The sample must also fit into fig. 5 jig of BS1363.
12.	Ball pressure test	A steel ball of 5mm in diameter is applied with 20N force on the sample at a temperature of 75±5°C for 1 hour. The sample is then cooled by cold water.	The diameter of the impression shall not exceed 2mm.
13	Glow wire test	The tip of the glow wire heated electrically to 750±10°C shall be applied at the portion between the current-carrying pins for a period of 30s.	Any flame and glowing shall extinguish within 30s after the removal of the glow-wire. There shall be no ignition of the tissue papernor sorching of the board.

DRAWN:	ROBIN LIU	06/11/20	TITLE : BRITISH PLUG
CHECK:	<i>ROBIN</i>	<i>06/11/20</i>	
APPR:	<i>Feng</i>	06/11/20	
REV:	AI		
REFERENCE:			

3. CONNECTOR

REV	DESCRIPTION	DATE
BE	ADD IN CATALOGUE NO. HPC13S.	31/08/20
BF	ADD IN CATALOGUE NO. VNBC5S.	11/11/20

3.1. SCOPE

The connector shall be in accordance with IEC 60320-1 or EN 60320-1, Test specification - appliance couplers.

3.2. CONSTRUCTION

The connector construction shall comply with our catalogue No: VAC5S, APC5A, APC5S, APC5M, VAC5AR, APC5SM, DLC5A3, V1625, V1625A, VAC19, VAC17S, VSCC13, AVL13, APC13, APC13S, VSC19, V1625LA, VAC19A, VSCC15, APC5SP, APC13F, V1625BS, APC13G, VAC13A, VAC13S, PIC17S, VIC13A, DLC5U3, VAC13KS, SOC5S, V1625H, VAC19KS, DLC5E3, HPC13A, V1625AT, VAC17A, APC5SF, VCC13, VCC5S, APC13H, VCC17S, VAC19H, APC13FH, APC13HC, VAC17KS, DLC5CS3, VNC13S, HWC13U, VNC5S, VNC13A, VAC19LA, VAC13AD, MS225A, VNC21S, VAC5ALS, VSCC21A, VSCC21, VNBC13S, HPC13S & **VNBC5S**.

"All connectors complying to Standard Sheet C5, C13, C15, C15A, C17, C19 and C21"

3.3. CHARACTERISTICS

NO.	TEST ITEM	DESCRIPTION	ACCEPTANCE CRITERIA
1.	Moisture resistance test	Samples are kept in a humidity cabinet containing air with a relative humidity between 91 to 95% and a temperature of 20°C-30°C for a duration of 48 hours.	No damage
2.	Electric strength test	Voltages of 3000V±60V and 1500V±60V, with min. trip current of 100mA is applied for 60s±5s between current-carrying contacts and body and between each contacts respectively after the moisture resistance tests.	No flashover and breakdown
3.	Insulation resistance test	This test is measured with a D.C 500V after the moisture resistance test. Readings are taken after 60s ± 5s of application of voltage.	Min. 5 M Ohm
4.	Withdrawal force test	<p>i) Min. 1.5N (2N for 16A) - A single pin made to the minimum dimension is inserted into the connector. The pin, together with the weight should exert a force of 1.5N (2N for 16A connector). Each individual pole of the connector is tested separately.</p> <p>ii) Max. 50N (60N for 16A) - Insert and withdraw the connector from a socket having pin dimension to the maximum and shroud dimension to the minimum for 10 times. The connector is then inserted again into the socket hang with a total weight of 50N(60N for 16A). The weight consist of a principal weight which is 90% of the total weight and a supplementary weight of 10%.</p> <p>The test is repeated for hot connector with temperature of 120°C±2°C on the pins.</p>	<p>i) The pin with the weight should not be withdrawn from the connector for more than 3 seconds.</p> <p>ii) The connector shall be withdrawn from the socket. If not the supplementary weight is lifted from a height of 5cm and drop. The connector must be withdrawn.</p> <p>The test is repeated after temperature rise test.</p>

DRAWN:	MEI MAN	11/11/20	TITLE: EUROPEAN & BRITISH APPLIANCE COUPLERS
CHECK:	Feng	11/11/20	
APPR:	Chun	11/11/20	
REV:	BF		
REFERENCE:			

NO.	TEST ITEM	DESCRIPTION	ACCEPTANCE CRITERIA
5.	Glow wire test	Glow wire is applied for 30s with temperature of 750°C on inserts and housings retaining contacts and 650°C on elsewhere.	Flame (if any) shall be self-extinguished within 30s . upon the removal of the glow wire and molten droplets shall not ignite paper.
6.	Bending test	The sample shall be loaded with a weight of 10N for 0.75mm ² or 20N for 1.00mm ² or bigger and the oscillating member shall be moved backward and forward through an angle of 90°(45° on either side of the vertical) the number of flexing being 20,000.A rated current is applied. For round cord, the sample is turned 90 degree around the axis of cable after 10,000 cycles. The flexing is further completed in this axis. Flat cable is flexed only along the bigger axis of the cable.	There shall be no complete breakage of any of the conductor. Broken conductor shall not have pierced the insulation.
7.	Tumbling test	The sample is dropped from a height of 50cm onto a steel plate(3mm thick) for a total of 500 times.	No damage to impair further use of connector.
8.	Breaking capacity test	The connector is connected and disconnected 50 times (100 strokes) with the inlet at a rate of 30 strokes per minute with 275V and 1.25 times of rated current.	No flashover or sustained arcing during the test and no damage to impair further use of connector.
9.	Normal operation test	Test is similar to breaking capacity except that the test voltage is 250V with the connector connected and disconnected with the inlet for 1000 times (2000 strokes) with rated current and 3000 times (6000 strokes) without current.	Withstand electric strength at 1500V for 1 min, and show no damage.
10.	Temperature rise test	An alternating current at 1.25 times rated current is passed through the current carrying contacts for 1 hour.This is repeated for connector with earth contact passing current between earth and each of the current carrying contacts.	The temperature rise shall not exceed 45K.
11.	Cord-anchorage test	The cord is subjected to pulls of 50N(2.5A) or 60N(others) for 100 times each time for 1 sec. without jerk.Thereafter the cord is subjected for 1 min. to a torque of 0.15Nm(0.75mm ²) or 0.25Nm(others).	The cord shall not be damaged and shall not been displaced by more than 2mm.
12.	Heat deformation test	Samples are kept for 1 hour in a heating cabinet at temperature of 100±2°C.	No damage to impair further use of connector.
13.	Heat pressure test	A pressure of 20N is applied at a temperature of 100°C ± 2°C for 1 hour.	No damage to impair further use of connector.

DRAWN:	MEI MAN	11/11/20	TITLE: EUROPEAN & BRITISH APPLIANCE COUPLERS
CHECK:	<i>Feng</i>	11/11/20	
APPR:	<i>Chun</i>	11/11/20	
REV:	BF		
REFERENCE:			

NO.	TEST ITEM	DESCRIPTION	ACCEPTANCE CRITERIA
14.	Aging test	The samples are kept for 168 hours in a heating cabinet at a temperature of 80±2°C.	No damage & marking shall be legible.
15.	Ball pressure test	A ball of 5mm in diameter is applied on the connector with the following temperature with 20N force for 1 hour. i) 125°C for hot connectors. ii) 125°C for parts retaining current carrying parts and earth circuit. iii) 75°C for other parts for cold connector. The connector is then cooled down to room temperature with cold water.	The diameter of the impression shall not exceed 2mm.

DRAWN:	MEI MAN	11/11/20	TITLE: EUROPEAN & BRITISH APPLIANCE COUPLERS
CHECK:	<i>Feng</i>	11/11/20	
APPR:	<i>Chun</i>	11/11/20	
REV:	BF		
REFERENCE:			

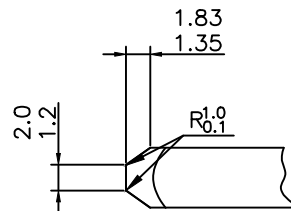
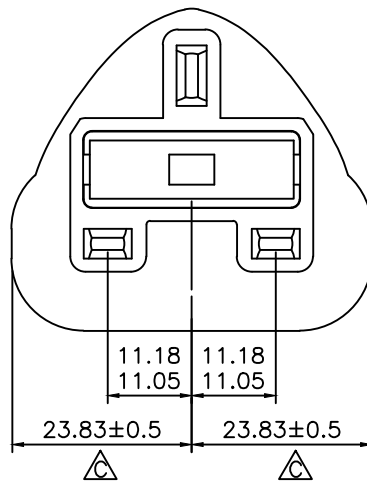
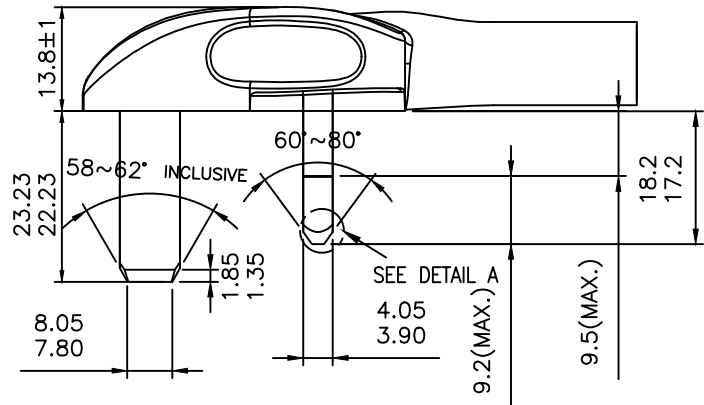

DETAIL A

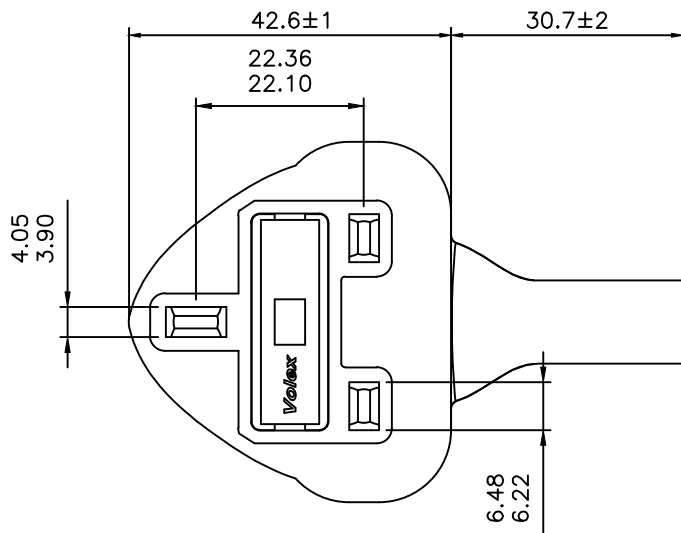

REV.	DESCRIPTION	DATE
	CHANGE DIM FM. '68.3±3' TO '42.6±1 & 30.7±2' AS SHOWN.	31/05/16
	CHANGE PRODUCT VIEW AS SHOWN.	
C	CHANGE DIM. '47.7±0.5' TO '23.83±0.5 (2X)' AS SHOWN.	20/12/16

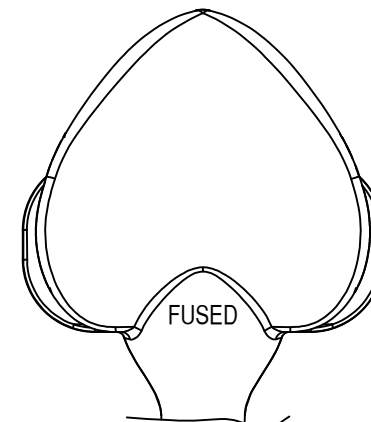
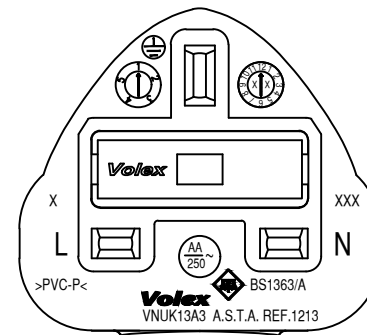

MARKING DETAILS

NOTE :

- 1.) ALL DIMENSIONS IN mm.
- 2.) X - CAVITY NO. (OPTIONAL)
- 3.) XXX - MANUFACTURING LOCATION.
- 4.) AA - RATING : (REFER TO THE TABLE)
- 5.) YEAR & MONTH & WEEK CODE INSERT.



YEAR XX
2015 = 15
2016 = 16



1 ~ 5 - week of the month

TABLE :

FUSE RATING (AA)	3	5	10	13
				✓

HG	HENG GANG (CHINA)		DRAWN	LI XIA	20/12/16	FILE NAME : A-PLUG/UK/ GENERAL/ VNUK13A3-YMW	TITLE : MOLDED PLUG VNUK13A3 (YEAR,MONTH,WEEK CODE)
SM1/SMI	ZHONGSHAN (CHINA)	X	CHECK	Tong xiali	20/12/16		
VH	HANOI (VIETNAM)		APPR	heith	20/12/16		
B	BATAM (INDONESIA)		REV.	C	SCALE		
VC	CHENNAI (INDIA)		REFERENCE :				
MANUFACTURE LOCATION MARK (' X ' IS APPLICABLE ONLY)			BRITISH APPROVAL				

REV.	DESCRIPTION	DATE
F	AMEND NOTE FOR ADD IN ITEM b.	29/08/08
G	UPDATE CHINESE MARKING PER ECN011-19.	01/11/19

*PRINT BLOCK TOPS WITH MACHINE NUMBERS

Bussmann

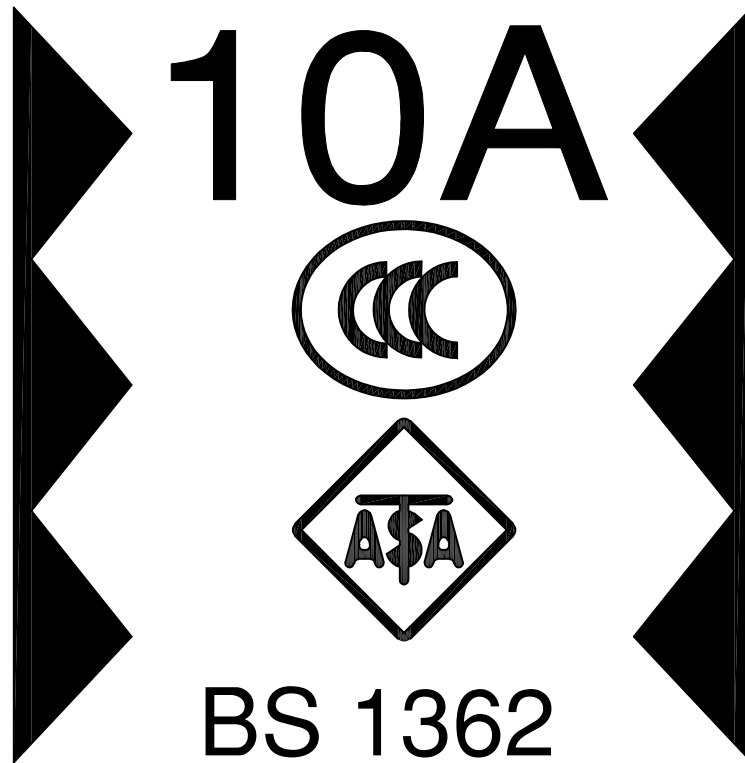

NOTE:

- (1) *PRINT BLOCK TOP (DOT LINE) = BUSSMANN INTERNAL IDENTIFICATION ON MACHINERY.
a: DIFFERENT LOCATION/NUMBER OF DOT LINE INDICATE DIFFERENT MACHINE NUMBER USED.
b: THE FUSE PRODUCE ON THE MACHINE #20 IS WITHOUT THE PRINT BLOCK TOP (DOT LINE).

DRAWN	PEIYUAN	01/11/19	REVISION:	TITLE : LEAD FREE FUSE (10A)
CHECK	ROBEN	01/11/19		
APPR	Jianying	04/11/19	G	
SCALE	N.T.S.			
REFERENCE :				
6210013 (TYPE REFERENCE TDC 180-10A)				

REV.	DESCRIPTION	DATE
B	ADD IN REFERENCE NO. '6210013'.	25/10/19
C	UPDATE CHINESE MARKING PER ECN011-19.	01/11/19

AsiaFuse
AF63C-10A
10A
BS1362
SS167

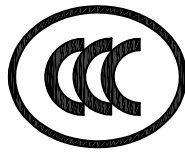

DRAWN	PEIYUAN	01/11/19	REVISION:	TITLE : LEAD FREE FUSE (10A)
CHECK	ROB-AN	01/11/19		
APPR	Jianying	04/11/19	C	
SCALE	N.T.S.			
REFERENCE :				
6210013				

REV.	DESCRIPTION	DATE
A	INITIAL RELEASE.	13/04/15

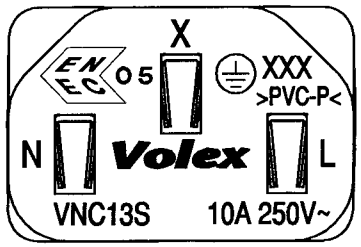
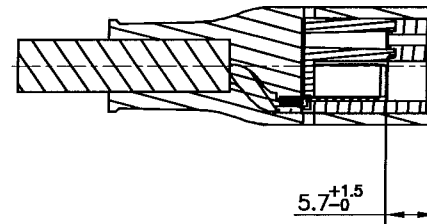
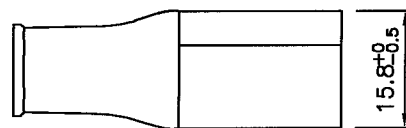
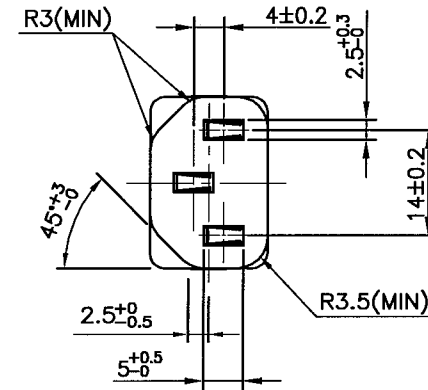
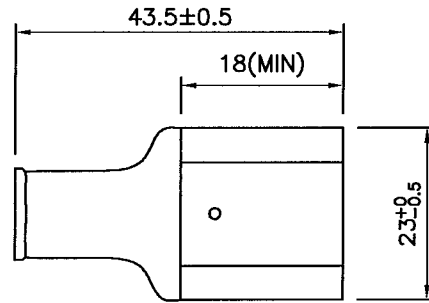

MARKING DETAILS :

- NOTES :
- 1.) ALL DIMENSIONS IN mm.
 - 2.) X - CAVITY NO. (OPTIONAL)
 - 3.) XXX - MANUFACTURING LOCATION

HG	HENG GANG (CHINA)		DRAWN	LI XIA	13/04/15	FILE NAME :	TITLE :	
SM1/SMI	ZHONGSHAN (CHINA)	X	CHECK	LI XIA	13/04/15	A-CONN/EURO/ GENERAL/ VNC13S-ENEC	MOLDED CONNECTOR VNC13S	
VH	HANOI (VIETNAM)		APPR	LI XIA	13/04/15	N.T.S.		
B	BATAM (INDONESIA)		REV.	A	SCALE			
VC	CHENNAI (INDIA)		REFERENCE :					
MANUFACTURE LOCATION MARK (* X * IS APPLICABLE ONLY)			EUROPEAN APPROVAL (ENEC)					