

**MODEL CM3-150
STANDARD**

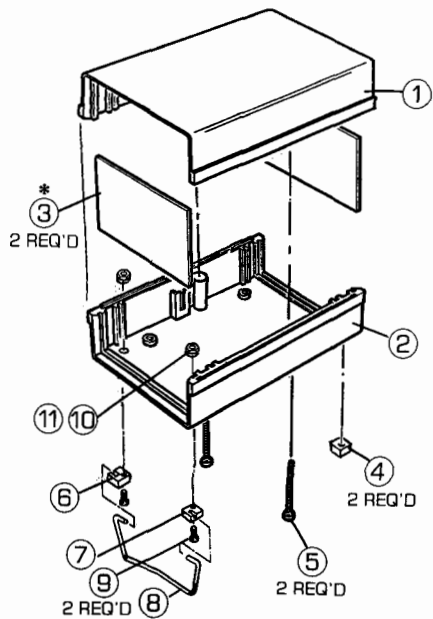

**MODEL CMB3-150
BAILED**

FOR ENGINEERING DRAWING SEE SIDE 2

MODEL NUMBER GENERATION

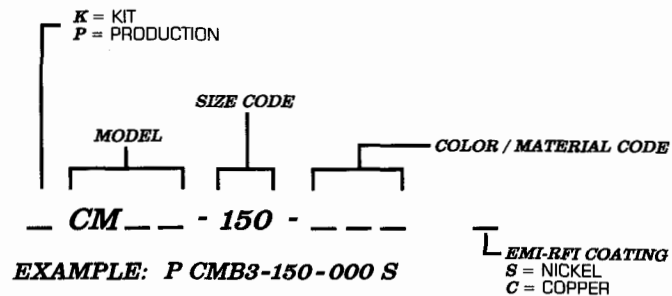

*SUPPLIED WITH KIT ONLY

MODEL	① TOP COVER	② BOTTOM COVER	*③ PANEL BLANK	④ FEET	⑤ SCREW	⑥ BAIL FOOT RIGHT	⑦ BAIL FOOT LEFT	⑧ BAIL	⑨ SCREW	⑩ NUT	⑪ LOCK WASHER
CM3 150	60270-01	60270-02	60272-01	60221-01	60227-03	-	-	-	-	-	-
CMB3 150	60270-01	63679-01	60272-01	62152-01	60227-03	61735-02	61735-01	63671-01	62153-01	63291-01	63676-01

COLOR / MATERIAL CODE

COLOR	94HB	94VO
BLACK	000	028
GREY	001	024
TAN	002	025
P.C.BONE	039	060

**CM3-150
CMB3-150**



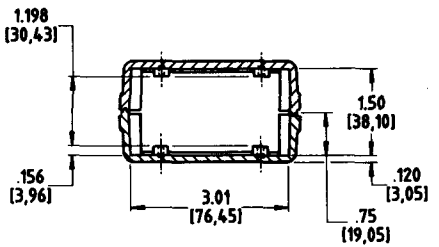
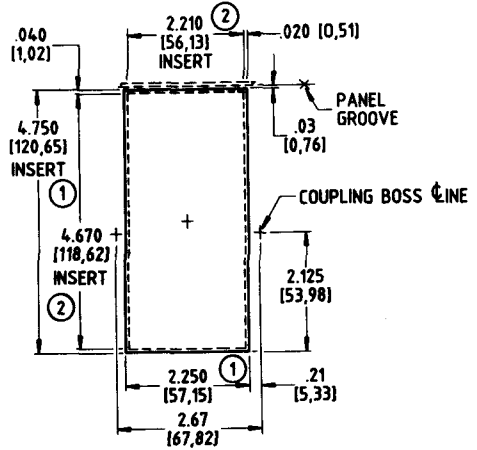
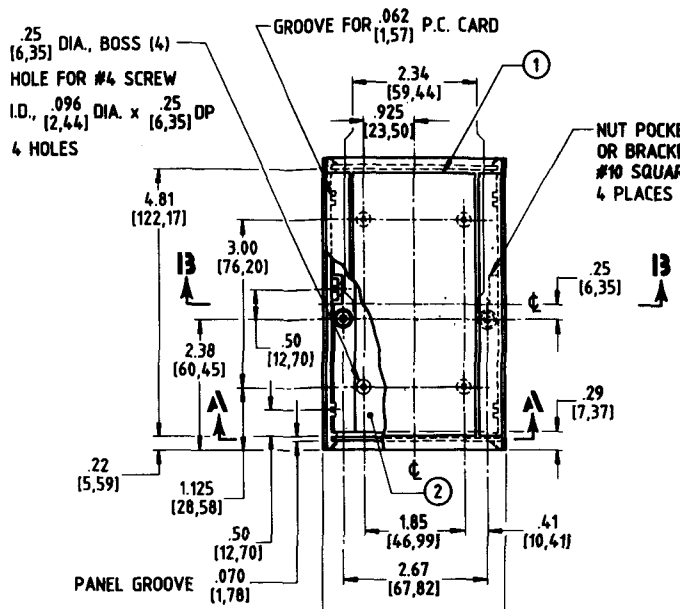

SECTION B-B

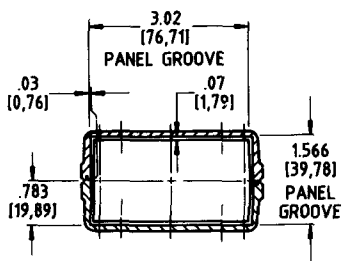
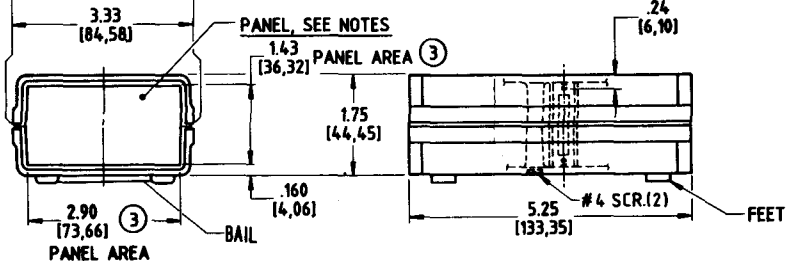

SECTION A-A

INCHES
[mm]

NOTES
PANEL SIZE
 1.563±.005 [39,70±0,13]H, x
 3.00±.01 [76,20±0,25]W, x
 .062±.005 [1,57±0,13]TH'K.

- ① EXTERIOR INSERT AREA, FOR IN MOLD MODIFICATION. TYPICAL ON TOP AND BOTTOM COVERS.
- ② INTERIOR INSERT AREA, FOR IN MOLD MODIFICATION. TYPICAL ON TOP AND BOTTOM COVERS.
- ③ USABLE PANEL AREA.

CM3-150
CMB3-150

