



Datasheet

RS PRO Sub-Miniature Pushbutton Switches

Stock number: **1759575,1759583,1759594,
1759553**

EN



The picture above is for reference only.

Specifications:

RATING : 5-24VADC/1A PULSE MODE.

OPERATING LIFE : 50 MILLION CYCLE MIN.

CONTACT RESISTANCE : 1Ω MAX.

OPERATING TEMPERATURE: -20°C to 65°C.

RS Part no.

175-8650	175-9575	TZ19N-B4-F1FN00-00D101
175-8646	175-9583	TZ19N-B4-F1MN00-00D101
175-8651	175-9594	TZ19N-B4-F1FE00-3CD101
175-8647	175-9553	TZ19N-B4-F1ME00-3CD101

Specifications:

1. OBJECTIVE :

This specification defined material, performance, quality and reliability requirements of the Dailywell's Piezo Switches and cable assembly.

2. SCOPE:

This specification provides information and requirements regarding application of the Dailywell's piezo switches and cable assembly.

3. GENERAL:

This document is composed of the following sections.

Paragraph	Item	Page
1.0	OBJECTIVE	1
2.0	SCOPE	1
3.0	GENERAL	1
4.0	APPLICATION DOCUMENTS	1
5.0	REQUIREMENTS	2
5.1	DESIGN AND CONSTRUCTION	2
5.2	MATERIALS	2
5.3	RATING	2
5.4	ELECTRICAL CHARACTERISTICS	3
5.5	MECHANICAL CHARACTERISTICS	3
5.6	ENVIROMENTAL CONDITIONS	4
6.0	TEST SEQUENCE FOR QUALIFICATIONS	4-5
7.0	PACKING AND PACKAGE	6
8.0	REVISION HISTORY	6

4. APPLICABLE DOCUMENTS:

HSF per Dailywell's HSF-001 Rev. C
RoHS 2011/65/EU exemption per 7(c) - I
IP68 per IEC 60529
IP69K per IEC 60529

5. REQUIREMENTS:

5.1 DESIGN AND CONSTRUCTIONS

The switches Sealing IP requirement for panel mount applications.
Apply cable or terminal connect to the input of devices to enable power or signal.
These switches are not design for safety use.

5.2 MATERIALS

Bushing	Aluminum nature anodized
PCB	FR4 94V-O rated Tin plating
Sealing	Silicon, Epoxy.
Cable	UL 3386, UL10368 or Equivalent.
Connector	Customer design.
LED	RGB SMT type.

5.3 RATING

5-24VDC / 1A
5-24VAC / 1A
LED 5-24VDC

5.4 ELECTRICAL CHARACTERISTICS

Switch type	MOM. Pulse 200mS min.
Max. Current	1A max.
Contact Resistance	10Ω max.
Output mode	Transistor

5.5 MECHANICAL CHARACTERISTICS

Actuation Force	2N-5N
Operating Life	10 Million cycle expectancy.
Cable retention force to Switch	10 KG min.
Connector mating force	By connector define
Connector un-mating force	By connector define

5.6 ENVIROMENTAL CONDITIONS

Operating Temperature	-20°C to +65°C
Storage Temperature	-40°C to +85°C
The Salt Test	See test sequence
HSF	See test sequence

6. TEST SEQUENCE FOR QUALIFICATIONS:

Electrical Parameter			
ITEM	DESCRIPTION	TEST CONDITIONS	REQUIREMENTS
1	Visual Examination	By Visual Examination check without and out pressure & testing.	There shall be no defects that affect the serviceability of the product.
2	Contact Resistance	@5VDC 1A. For transistor resistance from drain to source	10Ω Max
3	Current Rating	With 5Ω resistor	1A / 5VDC

Oct. 24. 2017

Mechanical Parameter			
ITEM	DESCRIPTION	TEST CONDITIONS	REQUIREMENTS
1	Operating Life	Life cycle tester	10 million cycle.
2	Cable retention force to switch	Force Analyzer	10KG min.
3	Connector mating force	Force Analyzer	By connector define
4	Connector un-mating force	Force Analyzer	By connector define

Environmental Parameter			
ITEM	DESCRIPTION	TEST CONDITIONS	REQUIREMENTS
1	Operating Temperature	① -20±3℃ for 96 hours. ② 65±3℃ for 96 hours.	Functions
2	IP 68	IEC 60529	Functions
3	Salt spray Testing	Following the test set forth below the sample shall be left in normal temperature and humidity conditions for an hour before the measurements are made: ① Temperature: 35±2 °C. ② The ratio of salt-water : 5%. ③ The spray amount of salt- water : 1~2 ml/h. ④ Time: 48 hours.	The testing standard based on bubble, crack, And magnifying glass with gauge.
4	HSF	Refer to RoHS Standard : The electronic electrical machinery product limits with six big chemical materials.	Cd < 100ppm. Pb < 1000ppm Hg < 1000ppm Cr6+ < 1000ppm PBB、PBDE < 1000ppm

Oct. 24. 2017

7. PACKING AND PACKAGE:

ESD bag, paper box.

8. REVISION HISTORY:

Rev.	Description	Date
R01	Research Project	2017/10/24

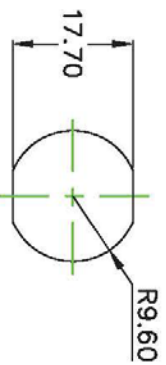
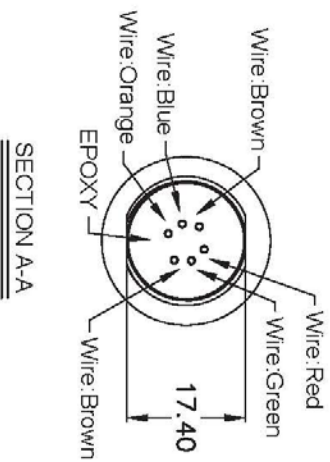
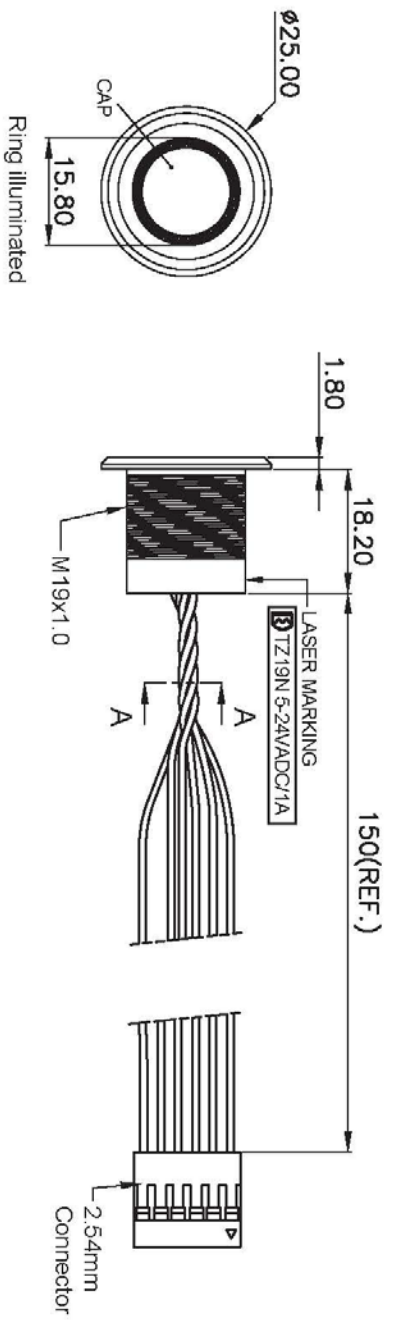

MAX. PANEL THICKNESS: 10.0mm[0.394]

SPECIFICATIONS

1. RATING: 5-24VADC/1A PULSE MODE.
2. OPERATING LIFE: 50MILLION CYCLE MIN.
3. CONTACT RESISTANCE: 1Ω MAX.
4. OPERATING TEMPERATURE: -20°C to 65°C
5. INDICATOR: 12-24V DC

MATERIAL:

- BUSHING: Aluminum alloy.
- CAP: PC; Aluminum alloy.
- SEALING: Silicone; Epoxy.
- O-RING: Silicone.
- HEX NUT: Nickel plated brass.

RoHS

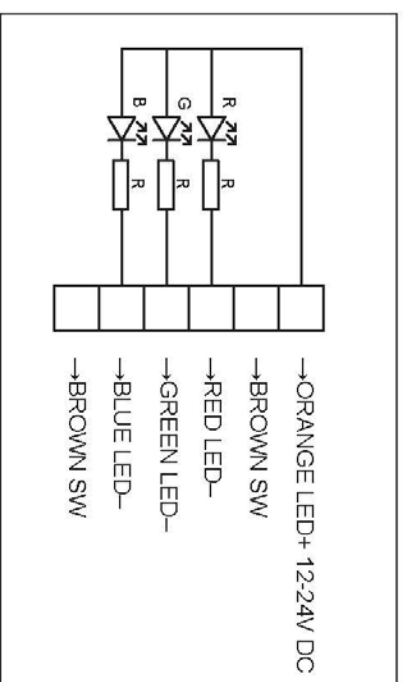
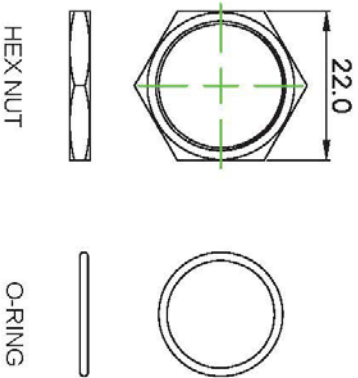

Application Diagram

TOLERANCE (公差):

- 0.00 mm ± 0.25mm
- 0.0 mm ± 0.40mm
- ANGULAR: ±5°

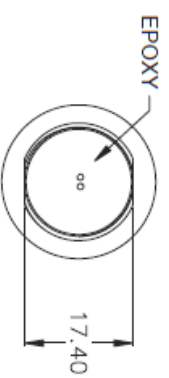
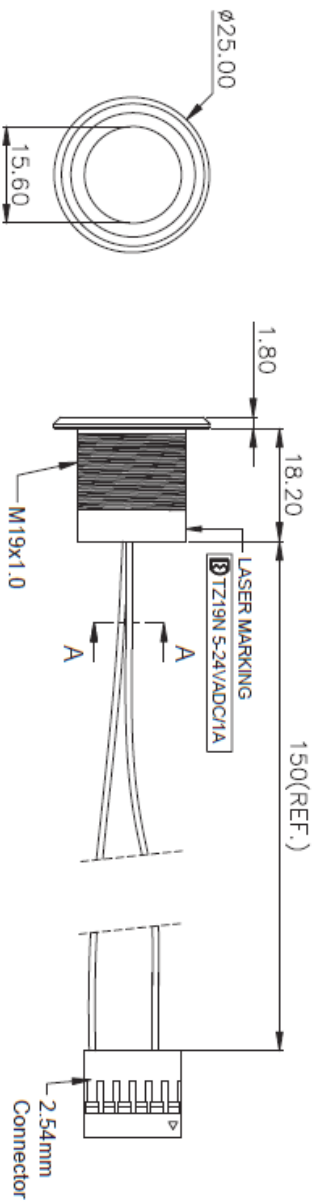

SECTION A-A

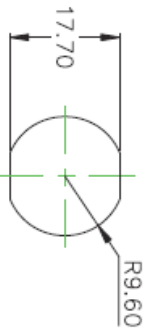

PANEL CUTOUT
MAX. PANEL THICKNESS: 10.0mm

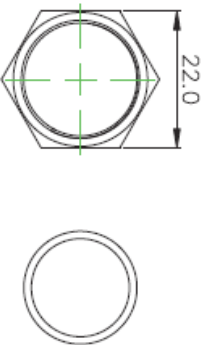

- MATERIAL:**
 BUSHING: Aluminum alloy.
 SEALING: Silicone, Epoxy.
 O-RING: Silicone.
 HEX NUT: Nickel plated brass.
 RoHS

HEX NUT

O-RING

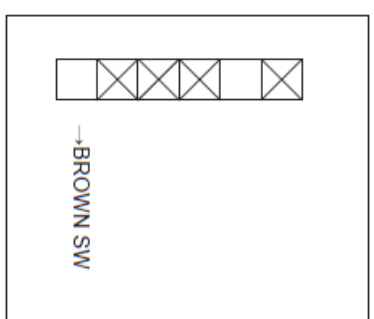

Application Diagram

- SPECIFICATIONS**
 1. RATING: 5-24VADC/1A PULSE MODE.
 2. OPERATING LIFE: 50MILLION CYCLE MIN.
 3. CONTACT RESISTANCE: 1Ω MAX.
 4. OPERATING TEMPERATURE: -20°C to 65°C