

FEATURES

- Extended motor life
- Leak prevention
- High-quality construction
- High efficiency and high performance
- Outstanding airflow/size ratio

RS PRO AC AXIAL FAN

RS Stock No.: 2399458



RS Professionally Approved Products bring to you professional quality parts across all product categories. Our product range has been tested by engineers and provides a comparable quality to the leading brands without paying a premium price.

Product Description

These RS PRO Axial Fans are ideal for telecoms servers with high density systems where powerful fans are required to dissipate heat. In these extreme performance environments where higher speed and higher capacity hard drives are more susceptible to vibrations, these fans can offer a high airflow/ pressure and low vibration solution to meet the requirements.

Besides the great performance, benefits also include:

1. High reliability and long-life which can save the customer the cost of maintenance and downtime.
2. EMC solution built into fan unit.
3. High PQ Performance which provides reliable solution when Telecom systems are required to dissipate heat
4. Low noise design
5. High efficiency reduces power consumption and meets ErP standard

General Specifications

AC FAN 60 x 60 x 25 mm	4200 RPM, 28.2 CFM, 6.3 mm-H ₂ O, 35.2 dBA
------------------------	---

Mechanical Specifications

Sleeve BEARING	Aluminum; Impeller Plastic (94V-0)
----------------	------------------------------------

Electrical Specifications

Voltage 230 V ac	Operation Voltage: 190~240 V AC, 0.02 A
------------------	---

Classification

Safety Certification	UL, TUV, CE

Approvals

Quality System Approval	ISO9001
Environmental system Approval	ISO14001

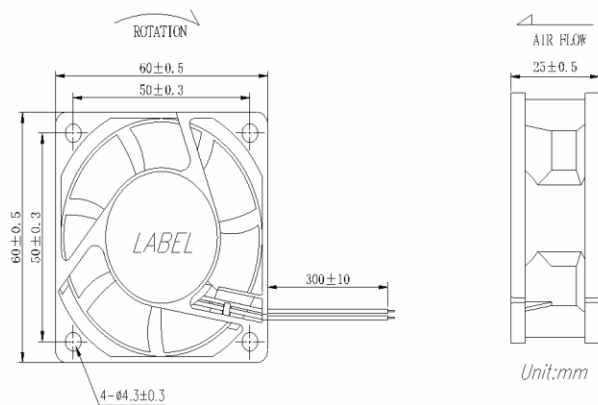
**NOTE:**

L LEAD
WIRES BLACK
WIRE x 2