



Product Datasheet

ENGLISH

Pushbutton Switch

Switch Pushbutton Maintained

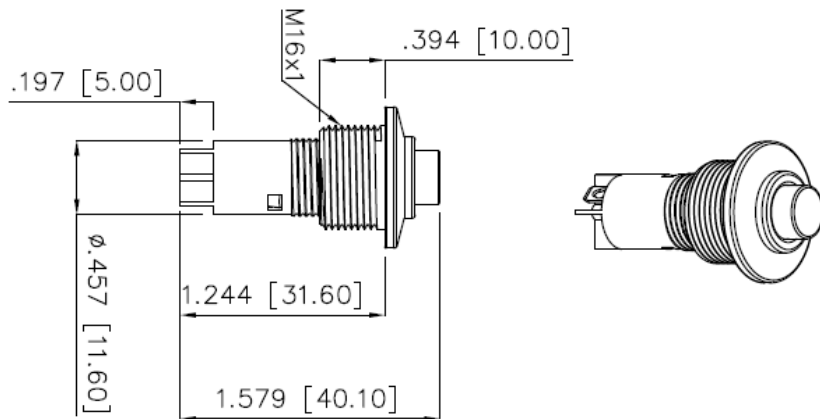
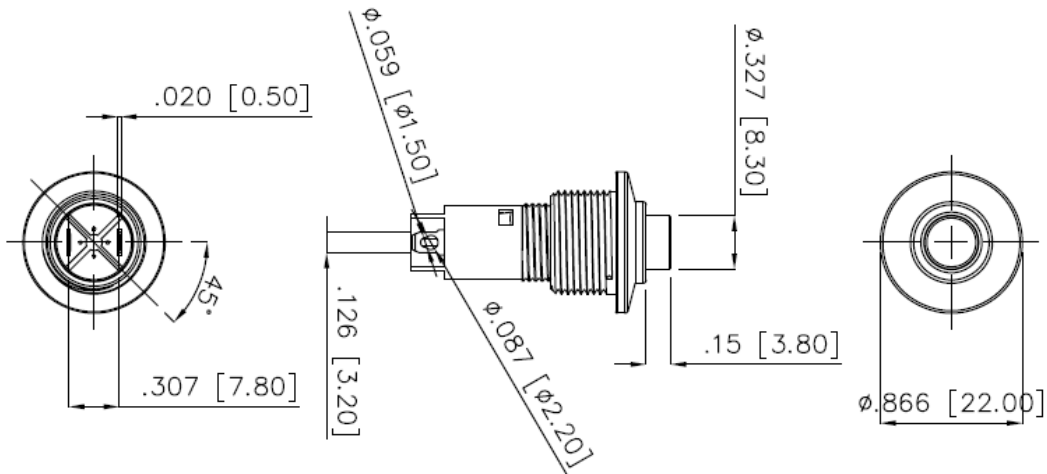



Package Contain:

- 1 x Pushbutton Switch
- 1 x Hex Nut
- 1 x Washer

Specification:

SWITCH TYPE:		8200618
POLES/THROWS:		SPST
SWITCH FUNCTIONS:		OFF-ON
ELECTRICAL & MECHANICAL CHARACTERISTICS	CONTACT RATING:	MAX. 10Amps @ 125VAC, 5A @ 250VAC
	ELECTRICAL LIFE:	30,000 make-and-break cycles at full load
	MECHANICAL LIFE:	Min. 30,000 cycles without load
	CONTACT RESISTANCE:	10m-ohms max. initial @ 2-4VDC, 100mA
	INSULATION RESISTANCE:	Apply 500VDC for 1min±5sec. After which measurement to be made between live parts and dead-metal parts shall result 1000M-ohms min.
	DIELECTRICAL STRENGTH:	1,500VAC (50Hz-60Hz) RMS @ sea level shall result no damage to parts arcing or flashover
	OPERATING TEMPERATURE:	-30Celsius degree to +85Celsius degree
	OPERATING FORCE:	600±100gf max.
	TORQUE:	20Nm max. applied to nut
	SOLDERING HEAT RESISTANCE:	Max soldering temperature @ 260Celsius degree, immersion time 5+/-1sec, frequency of soldering process @ 2 times max.
	SOLDERING ABILITY:	Per MIL-STD-202F method 208D,max soldering temperature @ 260Celsius degree, flux 5-10sec, duration of solder immersion 5+/-1sec. shall result no anti-soldering and the coverage of dipping into solder must be more than 90%
	COLD TEST:	Stored at temperature -30(+/-3)Celsius degree for 48 hours, shall result no changes to switch's electrical performance
	HOT TEST:	Stored at temperature +85(+/-3)Celsius degree for 48 hours, shall result no changes to switch's electrical performance
	HUMIDITY TEST:	Stored at temperature 40(+/-3)Celsius degree with relative humidity 90%~95% for 48 hours, shall result no changes to switch's electrical performance
SALT SPRAY RESISTANCE:	Stored at temperature @ 35(+/-3)Celsius degree, and salt solution concentration of 5% with full air temperature @ 47(+/-3) Celsius degree and air pressure 1.0kg for 48 hours. The switch shall result no corrosion as well as no apparent changes to its functional performance. Per ASTM-B117 & JIS-Z371 STD.	
CHA RAC TERI	BASE:	FR52 flame retardant (UL94V-0)



	CASE:	Nylon 66 (UL94-HB)
	BEZEL:	Black anodized aluminium alloy
	PLUNGER:	POM (UL94-HB)
	TEETH:	PEI
	CONTACT PIVOT:	Copper
	CONTACT & TERMINALS:	Silver-inlay alloy
	BUTTON:	Red, ABS
	BUTTON SPRING:	Piano wire
	BASE SPRING:	Piano wire
	CONTACT SPRING:	Piano wire
	HARDWARE:	Nut, brass nickel plated Washer, steel nickel plated
SOLDERING & CLEANING RECOMMENDATION	HAND SOLDERING:	Max. temperature @ 350Celsius degree (662F)with continuous soldering time @ 3sec. max. Recommend lead-free solder paste Sn96.5Ag3Cu0.5, soldering irons of 25-40 watts max. and solder of 0.030~0.040 dia.
	WAVE SOLDERING:	No-clean flux wave soldering is recommended so the switch does not require washing after soldering process. Noted, not to have flux migrate inside the switch through the top of the housing or actuator to prevent contamination. Max temperature @ 260Celsius degree (500F) for 10 sec.
	CLEANING PROCESS:	Noted, the switch is “not totally sealed” so it is important not to immerse/spray or clean unsealed areas of the switch during flux removal. Improper cleaning could cause switch deficiencies such as intermittence or open contact failures
PACKAGE	INTERNAL PACKAGING:	1pcs per PE bag
	RoHS IDENTIFICATIONS:	Bag is attached with a label marking “RoHS”
PRODUCT HANDLING & STORING	<p>The switch is suitable for power rated applications, rating recommendation is per aforementioned above (Contact rating section)</p> <p>Problem relates to terminal oxidization can be prevented by storing product in an environment that is dry and cool with the relative humidity less than 90%. Noted, prior to mounting products onto circuit board as well as for unused units, it is recommended to keep them in the bag and with the bag sealed.</p>	