

## Datasheet

ENGLISH

# RS PRO, 12 V dc, 832 gcm, Brushed DC Geared Motor, Output Speed 35 rpm

Stock No: 417-9712



## Specifications:

Output Speed	35 rpm
Supply Voltage	12 V dc
Maximum Output Torque	832 g.cm
DC Motor Type	Brushed
Shaft Diameter	3mm
Power Rating	0.47 W
Gearhead Type	Planetary
Length	52.8mm
Width	16 (Dia.) mm
Current Rating	115 mA
Weight	47g

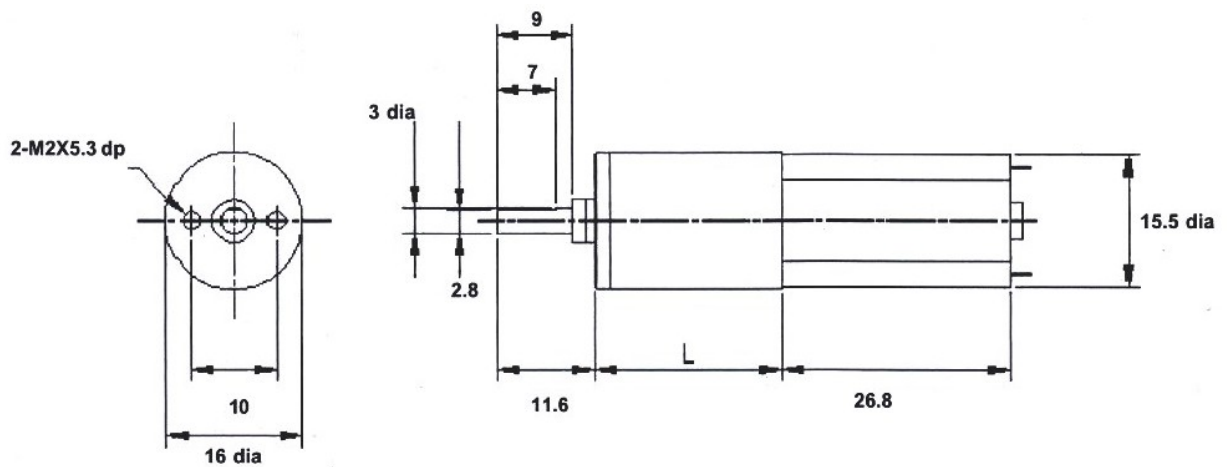

Operating relative humidity 20% ~ 85%  
 Operating temperature range -10°C ~ +60°C

Ratio	L
231:1	26.0mm

<b>Gearbox Housing material</b>	<b>Metal</b>
Backlash at no-load	< 3°
Bearing at output	Sleeve bearings
Radial load (10mm from flange)	< 0.5 kgf
Shaft axial load	< 0.5 kgf
Shaft press fit force max	< 1.5 kgf
Radial play of shaft	< 0.08mm
Thrust play of shaft	< 0.2mm

Reduction Ratio	Rated tolerance Torque	Max momentary Tolerance Torque	Efficiency
1/231	2.0 kgf-cm Max.	6.0 kgf-cm	50%

Reduction Table RPM SUPPLY VOLTAGE	3v	6v	9v	12v
417-9712	9	17	26	35

Note: Motor speeds may vary by (+) or (-) 12.5%  
 Note: It is not recommended to run the motor/gearbox combination at 1.5v