

General Description

The MAX17055G/MAX17055X evaluation kits (EV kits) are fully assembled and tested surface-mount PCBs that evaluate the stand-alone ModelGauge™ m5 host-side fuel gauge ICs for lithium-ion (Li+) batteries in handheld and portable equipment.

The MAX17055G/MAX17055X EV kits include the Maxim DS91230+ USB interface, IC evaluation board, and RJ-11 connection cable. Windows® based graphical user interface (GUI) software is available for use with the EV kit and can be downloaded from Maxim's website www.maximintegrated.com/evkitsoftware. Windows 7 or newer Windows operating system is required to use the EV kit GUI software.

Features

- ModelGauge m5 Algorithm
- Monitors 1-Cell Lithium-Ion Battery Packs
- Battery Pack Input Voltage Range of +2.3V to +4.9V
- On-chip Temperature Measurement and External Thermistor Measurement Network
- Optional On-Board PCB Trace Sense Resistor
- Windows 7 or Newer Compatible Software
- Proven PCB Layout
- Fully Assembled and Tested

MAX17055K EV Kit Files

FILE	DESCRIPTION
MAX17055K_Vx_x_x_x_Install.exe	Installs all EV kit files on your computer

Ordering Information appears at end of data sheet.

*ModelGauge is a trademark of Maxim Integrated Products, Inc.
Windows is a registered trademark and registered service mark of Microsoft Corporation.*

Quick Start

Required Equipment

- MAX17055G/MAX17055X EV kit
- 1-cell lithium-ion battery pack
- Battery charger or power supply
- Load circuit
- DS91230+ USB adapter
- RJ-11 6pos reverse modular cord
- PC with Windows 7 or newer Windows operating system and USB port

Procedure

The EV kits are fully assembled and tested. Follow the steps below to install the EV kit software, make required hardware connections, and start operation of the kits. The EV kit software can run without hardware attached. It automatically locates the hardware when connections are made. Note that after communication is established, the IC must still be configured correctly for the fuel gauge to be accurate. See the [Battery Selection](#) section for details.

- 1) Visit www.maximintegrated.com/evkitsoftware to download the latest version of the MAX17055K EV kit software. Save the EV kit software to a temporary folder and unpack the ZIP file.
- 2) Install the EV kit software on your computer by running the MAX17055K_Install.exe program inside the temporary folder. The program files are copied and icons are created in the Windows **Start** menu. The software requires the .NET Framework 4.5 or later. If you are connected to the Internet, Windows automatically updates .NET framework as needed.

- 3) The EV kit software launches automatically after install or alternatively it can be launched by clicking on its icon in the Windows **Start** menu.
- 4) Connect the DS91230+ adapter to a USB port on the PC. The DS91230+ is a HID device and is located automatically by Windows without the need to install additional drivers.
- 5) Make connections to the EV kit board based on cell pack configuration as shown in [Figure 1](#). The load or charger circuit can be connected at this time as well. The cell connects between the PACK- and PACK+ pads and the charger/load connect between the SYSGND- and SYSPWR+ pads.
- 6) Connect the RJ-11 cable between the USB adapter and the EV kit board. The GUI software establishes communication automatically.
- 7) At initial power-up, a battery profile must be created. The battery selection window opens and allows the user to generate a profile for the battery they are using. They can either select EZ configuration or if a custom .INI characterization file is available for the battery it can be selected at this time. See the [Battery Selection](#) section for details.

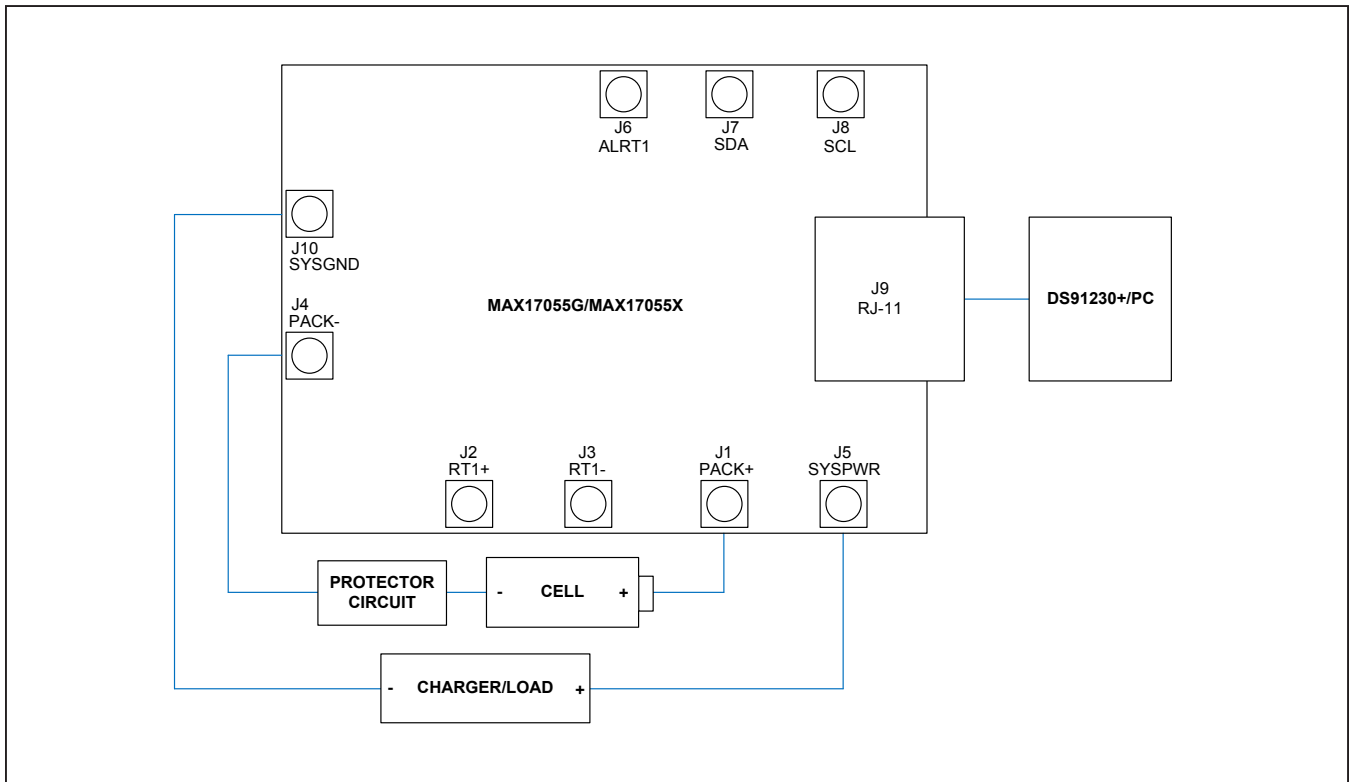

Figure 1. MAX17055 Board Connections

Detailed Description of Hardware

The MAX17055 EV kit board provides a variety of features that highlight the functionality of the IC. The following sections detail the most important aspects of the EV kit board.

Communication Connections

The RJ-11 connector provides all signal lines necessary for I²C communication between the IC and the software GUI interface. When developing code separately, connections to the communication lines can be made directly to the board. [Table 1](#) summarizes the connections. The user must apply the appropriate external pullup resistors to the communication lines when not using the DS91230+ communication interface.

External Thermistor

The MAX17055 can be configured to use internal temperature measurements or an external thermistor. All EV kit boards come with a thermistor installed as surface mount component RT1. If the application requires direct thermal contact to the cells, RT1 can be removed and replaced with a leaded thermistor connected between the RT1+/RT1- solder pads (J2 and J3).

Sense Resistor Options

All EV kit boards are shipped with an 0805 size 0.010Ω chip sense resistor installed. Oversized land pattern pads allow for different size sense resistors to be used if desired. Also, each board contains an optional 0.003Ω copper trace sense resistor that can be enabled if desired. To do so, the chip sense resistor must be removed and

0Ω jumpers must be resoldered to change the circuit. [Table 2](#) summarizes the changes. Note that the IC must be reconfigured to support the new resistor type.

Detailed Description of Software

The MAX17055G/MAX17055X evaluation kit software gives the user complete control of all functions of the MAX17055, as well as the ability to load a custom model into the ICs. Separate control tabs allow the user access to view real-time updates of all monitored parameters. The software also incorporates a data-logging feature to monitor a cell over time.

Software Installation

The software requires a Windows 7 or newer operating system. .NET version 4.5 is required for operation and is automatically installed if an older version of .NET framework is detected. To install the evaluation software, exit all programs currently running and unzip the provided MAX17055K Installation Package zipped file.

Double click the MAX17055K_V_x_x_x_x Install.exe icon and the installation process begins. Follow the prompts to complete the installation. The evaluation software can be uninstalled in the **Add/Remove** programs tool in the **Control Panel**. After the installation is complete, open the **Maxim Integrated/MAX17055K** folder and run **MAX17055K.exe** or select it from the program menu. [Figure 2](#) shows a splash screen containing information about the evaluation kit that appears while program is loading.

Table 1. Communication Line Solder Points

COMMUNICATION LINE	CONNECTION POINT
SDA	J7
SCL	J8
GND	J10

Table 2. Sense Resistor Selection for MAX17055

COMPONENT	VALUE FOR SMD RESISTOR SENSE	VALUE FOR BOARD TRACE SENSE
R3	0Ω	Not populated
R4	Not populated	0Ω
R5	Desired sense value	Not populated
R6	Not populated	0Ω (R7 is trace resistor)

Communication Port

The EV kit software automatically finds the DS91230+ adapter when connected to any USB port. Communication status is shown on the right-hand side of the bottom status bar. See [Figure 3](#). If the adapter cannot be found, a “No USB Adapter” message is displayed. If the adapter is found, but the EV kit board cannot be found, a “No Slave Device” message is displayed. Otherwise, if communication is valid, a green bar updates as the software continuously reads the IC registers.

If the DS91230+ is connected, the status bar should be active. The bottom status bar also displays information on hibernation status, IC serial number, selected current-sense resistor value, selected battery profile, and IC’s firmware revision.

Battery Selector

The MAX17055 must always have a battery profile for the battery it is presently fuel gauging. The first time the MAX17055K software is run, the **Battery Selector Form** opens automatically to allow the user to set up the first profile. Afterwards, the user can launch the form either from the **Configure** tab or the **Device** pull-down menu. A new profile should be created for each individual battery monitored by the IC. Care should also be taken to always have the correct profile selected for the battery that is attached to the IC so that the fuel gauge is accurate and that save and restore information is properly maintained. Battery profile files are stored under **My Documents/Maxim Integrated/MAX17055/Batteries**. Custom .INI files are also automatically copied by the program to this location as well.

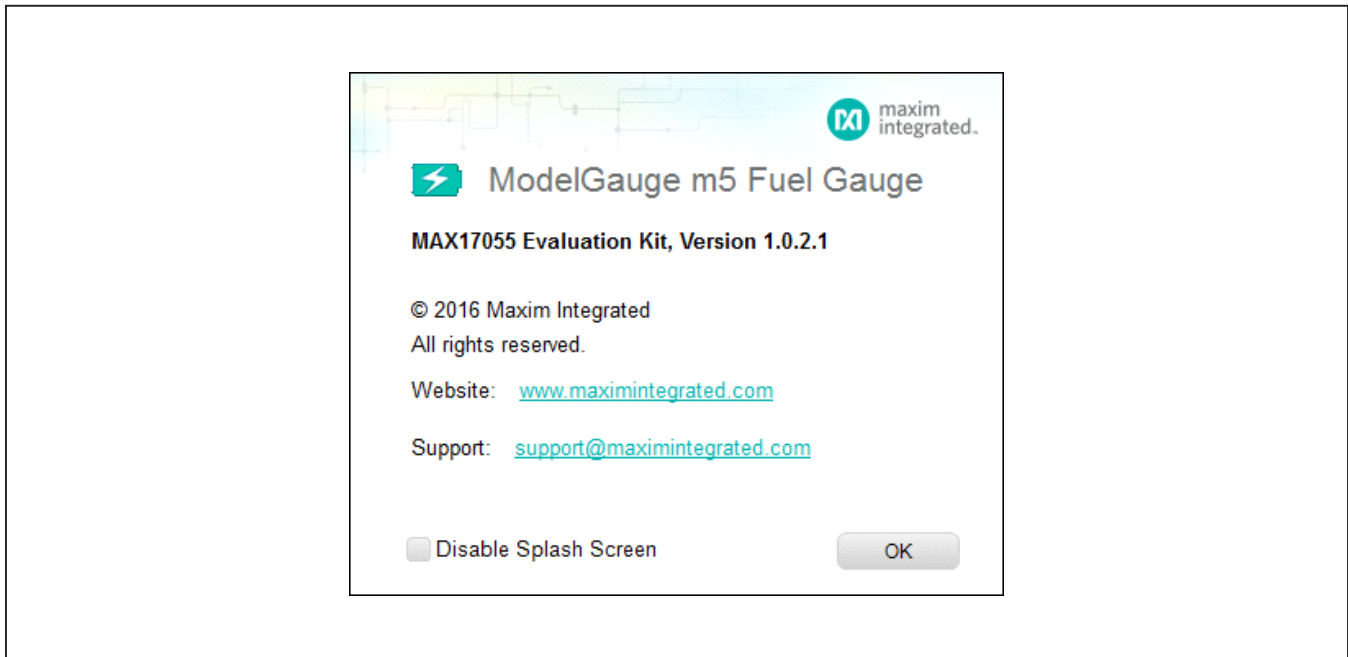

Figure 2. EV Kit Splash Screen

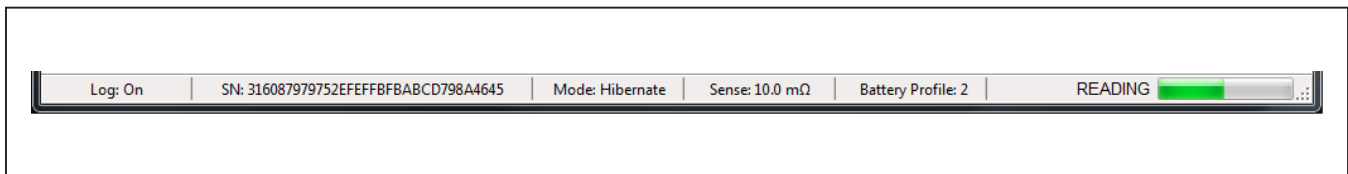

Figure 3. EV Kit Bottom Status Bar

Figure 4 shows the format of the Battery Selector Form. To change known batteries, the user should select the proper battery profile from the pull-down box and then click **Save Profile and Update IC**. To create a profile for a new battery, follow these steps:

- 1) Select a new profile number from the **Battery Profile** pull-down box.
- 2) Give the profile a detailed description so that it can easily be matched to its battery.
- 3) If no custom .INI file has been created, select the **Use Default IC Settings (EZ Config)** option and fill out the five settings for your application. Proceed to Step 5.

- 4) If a custom .INI file has been provided by Maxim, select **Load INI File** option and select the file.
- 5) Select to restore battery history data after model load or not to.
- 6) Click **Save Profile and Update IC** to load the model and exit the form.

If the user ever wishes to delete a battery profile, select the profile number from the drop-down box and then click **Delete Profile** to remove it permanently.

Battery Selector

A battery profile must be loaded into the IC for proper operation. If this is the first time the software has been launched and no battery profiles are available, a new one must be created. Select either EZ Configuration or load the profile from an INI file. Also select whether or not to restore battery history information after the model is loaded. It is recommended to restore history information. A different profile should be kept for each battery used with the EV Kit. Make sure to label all batteries so that the correct battery profile is used each time.

Battery Profile: 2 | Description: Profile 2

INI File Option

Use Default IC Settings (EZ Config)

1500 Cell Size (mAH) | LiCoO2 (Common) Model ID*

3.3 Empty Voltage (V per cell)

100.00 Charge Termination Current (mA)

Charge voltage is greater than 4.275V

Load INI File

Path: N/A | Select File

Save and Restore Option

Restore Saved Fuel Gauge Data After Loading the Model

Use Existing IC Fuel Gauge Register Data After Loading the Model

Delete Profile | Cancel and Exit | Save Profile and Update IC

Figure 4. Battery Selector Form

Program Tabs

All functions of the program are divided under four tabs in the main program window. Click on the appropriate tab to move to the desired function page. Located on the **ModelGauge m5** tab is the primary user information measured and calculated by the IC. The **Graphs** tab visually displays fuel gauge register changes over time. The **Registers** tab allows the user to modify common fuel gauge registers one at a time. The **Configure** tab allows for special operations such as initiating fuel gauge logging and performing fuel gauge reset. All tabs are described in more detail in the following sections.

ModelGauge m5 Tab

The **ModelGauge m5** tab displays the important output information read from the IC. [Figure 5](#) shows the format of the ModelGauge m5 Tab. Information is grouped by function and each is detailed separately.

State of Charge

The **State of Charge** group box displays the main output information from the fuel gauge: state of charge of the cell, remaining capacity, time to full, and time to empty.

Cell Information

The **Cell Information** group box displays information related to the health of the cell such as the cell's age, internal resistance, present capacity, number of equivalent full cycles, and change in capacity from when it was new.

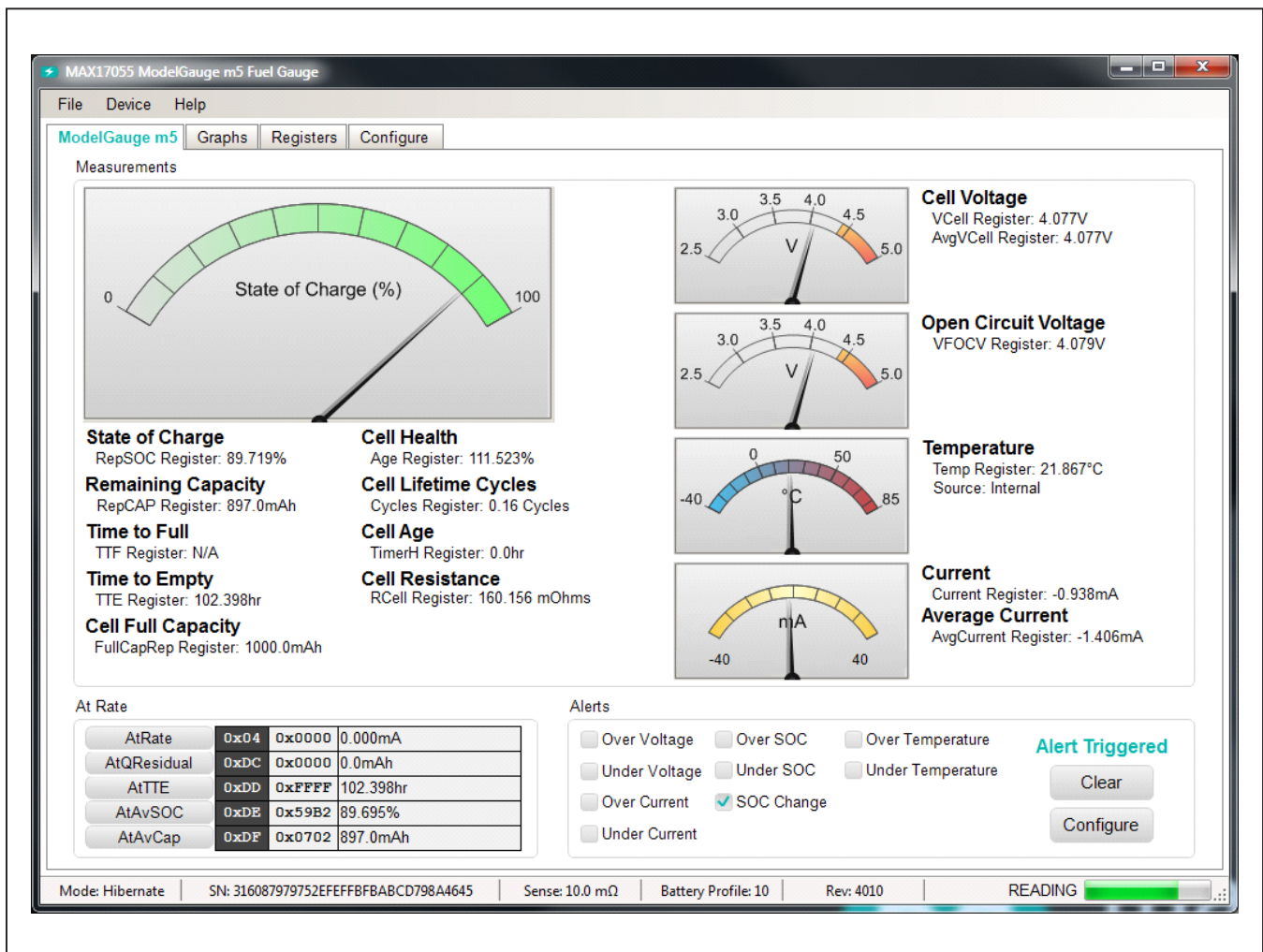

Figure 5. ModelGauge m5 Tab

Measurements

The **Measurements** group box displays ADC measurements that are used by the fuel gauge to determine state of charge.

Alerts

The **Alerts** group box tracks all eleven possible alert trigger conditions. If any alert occurs, the corresponding checkbox is checked for the user to see. The clear alerts button resets all alert flags. The configure button allows the alert threshold settings to be changed by the user. [Figure 6](#) shows the **Alerts Configuration** application form.

At Rate

The **At Rate** group box allows user to input a hypothetical load current and the fuel gauge calculates the corresponding hypothetical Qresidual, TTE, AvSOC, and AvCap values.

Graphs Tab

The **Graphs** tab displays up to 13 fuel gauge outputs. [Figure 7](#) shows the format of the **Graphs** tab. Graph information is grouped into four categories: voltages, temperatures, capacities, and currents. The user can turn on or off any data series using the check boxes on the right-hand side of the tab. The graph visible viewing area can be adjusted from 10 minutes up to 1 week. The graphs remember up to 1 week worth of data. If the viewing area is smaller than the time range of the data already collected, the scroll bar below the graphs can be used to scroll through graph history. All graph history information is maintained by the program. Graph settings can be changed at any time without losing data.

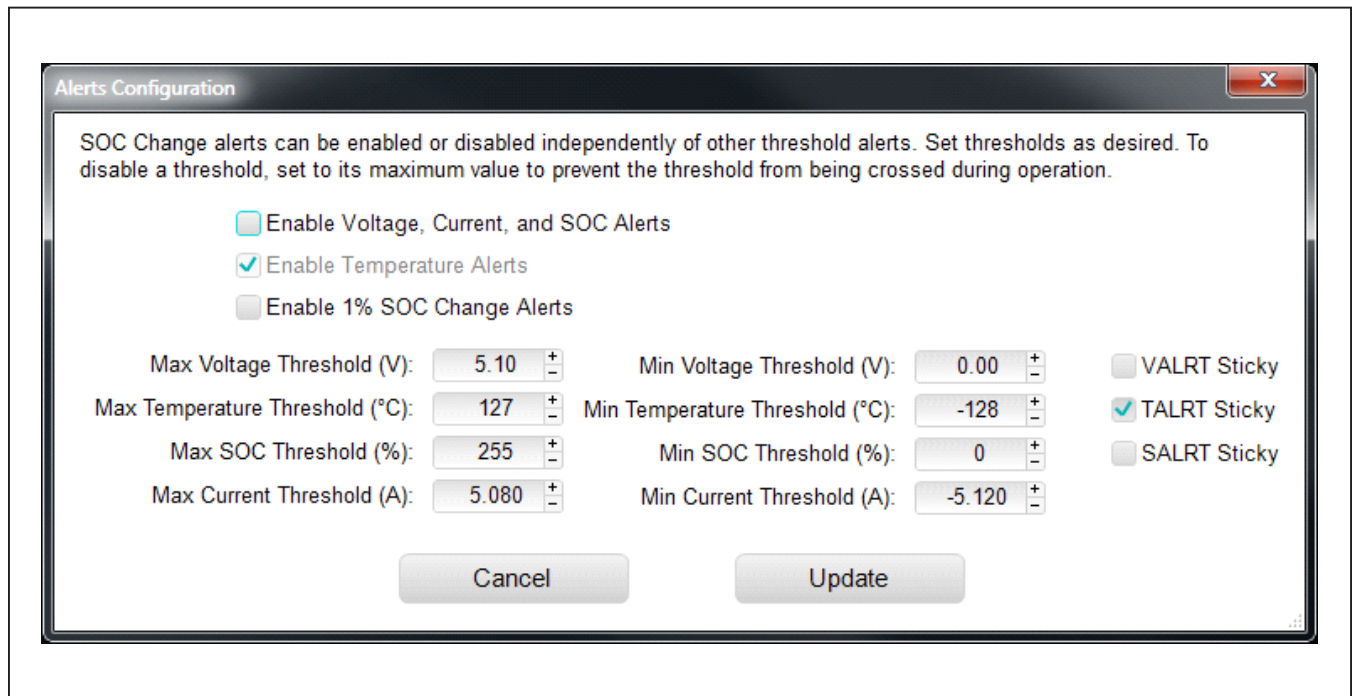

Figure 6. Alerts Configuration Form

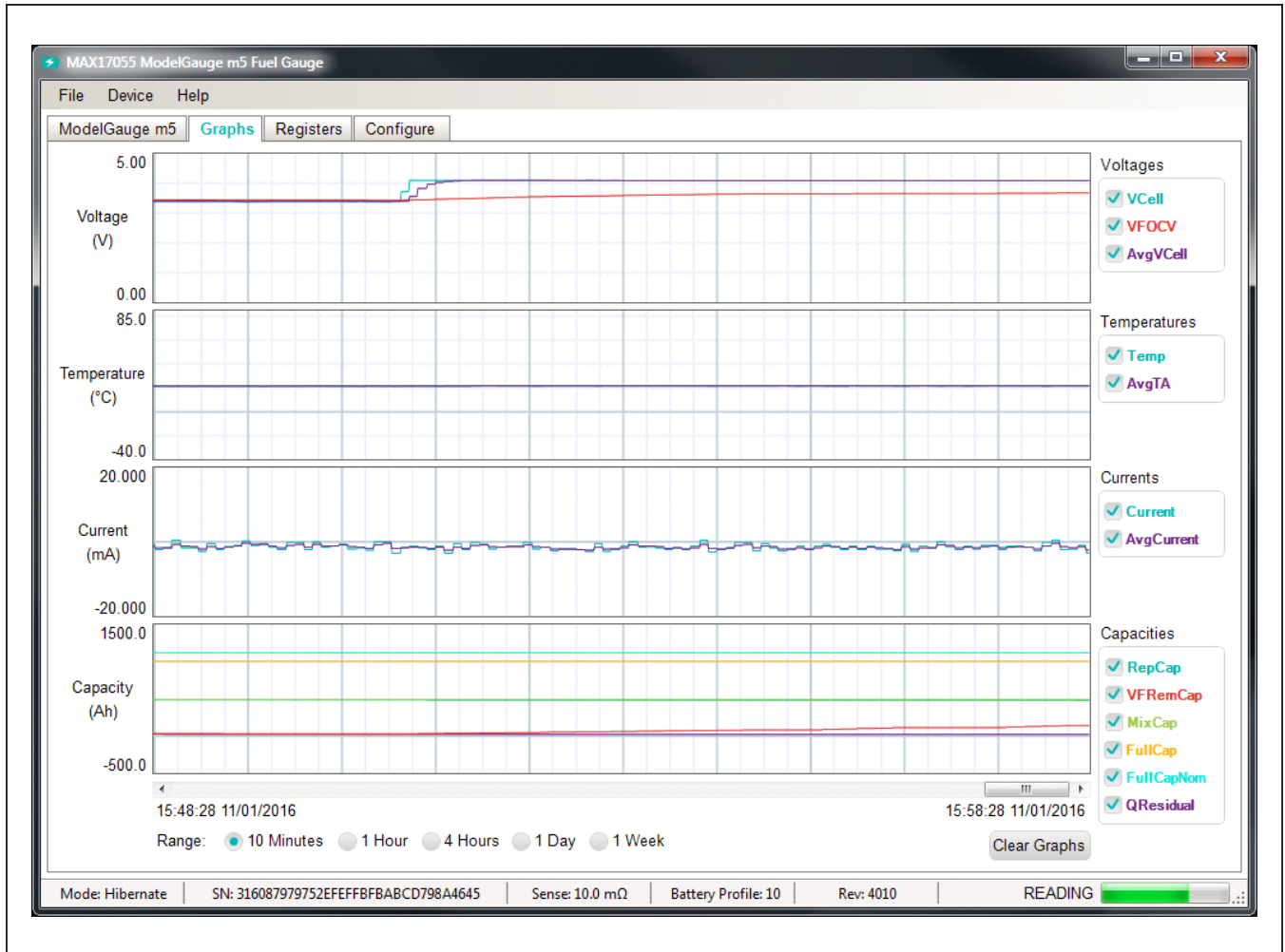

Figure 7. Graphs Tab

The **Registers** tab has a button to launch the register viewer form. The viewer can also be launched under the Device pull-down menu. The register viewer is a separate application window that allows systems with higher screen resolutions to see more IC registers simultaneously.

A 1920 x 1080 screen resolution allows the user to view all user registers at once on the screen with the register viewer. The viewer size can be adjusted. [Figure 9](#) shows the format of the register viewer form.

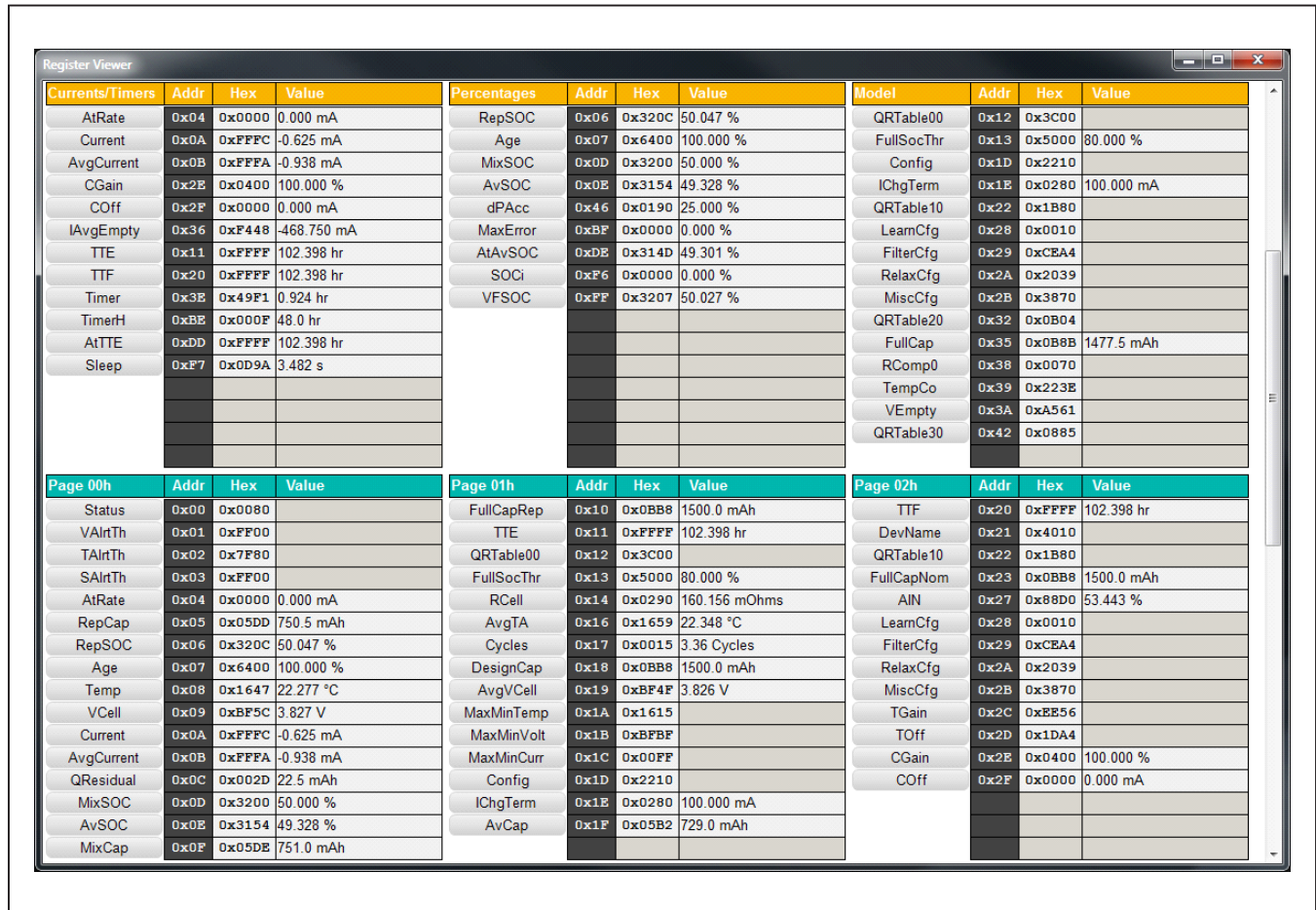

Figure 9. Register Viewer Form

Configure Tab

The **Configure** tab allows the user to access any general IC functions not related to normal writing and reading

of register locations. [Figure 10](#) shows the format of the **Configure** tab. Each group box of the **Configure** tab is described in detail in the following sections.

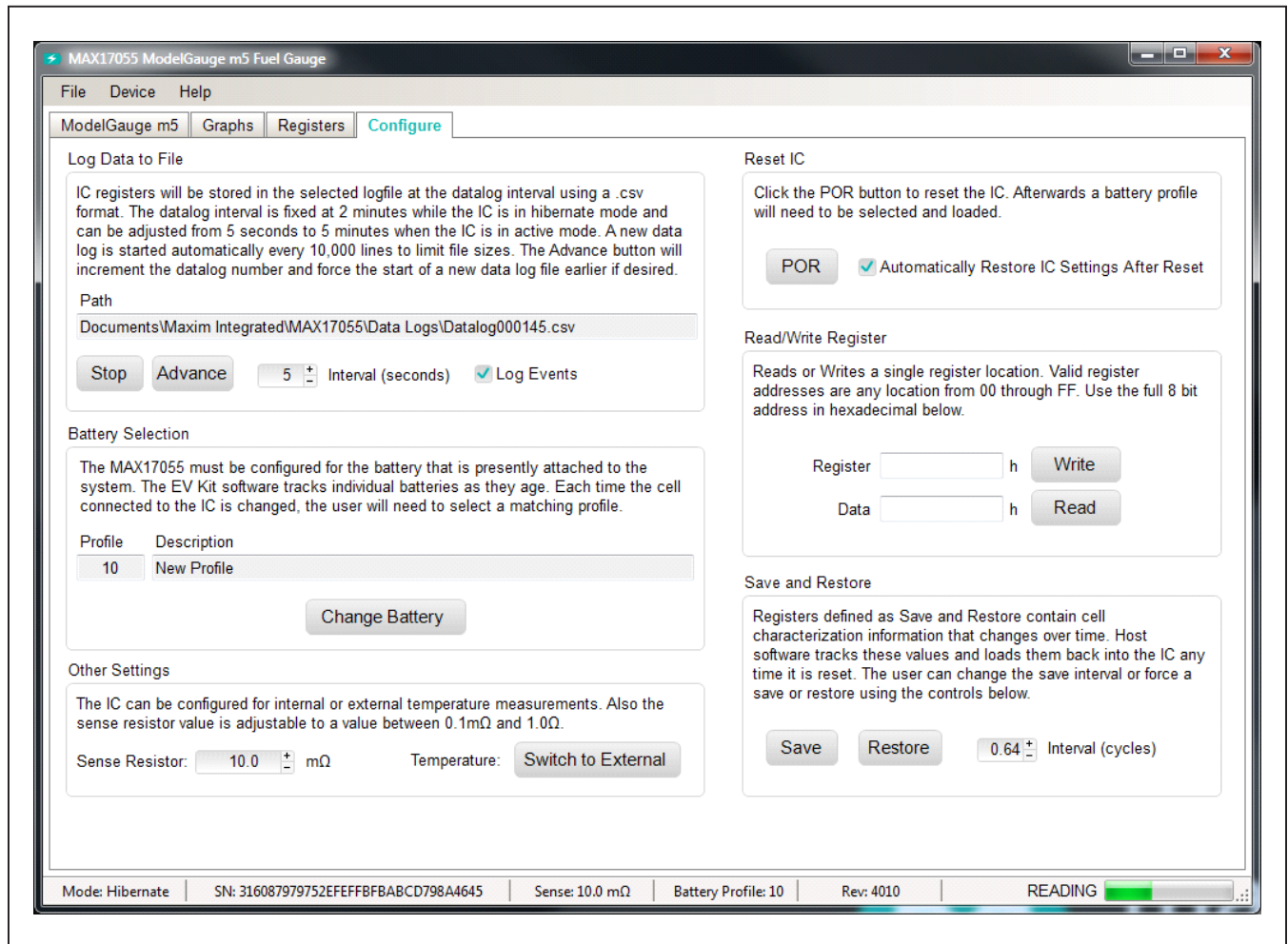

Figure 10. Configure Tab

Log Data to File

Data logging is always active when the kit software starts. The default data log storage location is the My Documents/Maxim Integrated/MAX17055/Data Logs/DatalogXXXXXX.csv where XXXXXX is the data log number. Each time the program is started, the previous data log reaches 10,000 lines, or the user clicks the **Advance** button, a new data log is started and the data log number is advanced. The user can stop or start data logging by clicking the **Stop/Start** button. All user available IC registers are logging in a .csv formatted file. The user can adjust the logging interval at any time. The user can also enable or disable the event logging at any time. When event logging is enabled, the data log also stores any IC write or reads that are not part of the normal read data loop and indicates any time communication to the IC is lost.

Battery Selection

The battery selection box shows which battery profile is presently selected and the user description of that profile. Clicking the **Change Battery** button opens the **Battery Selector Form** to allow the user to change the active profile, create a new profile, or delete old profiles. See the Battery Selector section for details.

Other Settings

The other settings box allows the user to change the sense resistor setting and select either internal or external temperature measurement. All capacity and current type registers use the sense resistor value to convert voltage

to current and updates occur immediately when the sense resistor value is changed.

Reset IC

Clicking the **POR** button starts the IC firmware reset sequence. Operation of the IC is restarted. If the associated check box is checked, IC settings such as the battery model, thermistor selection, and alert thresholds are reloaded into the IC. It is recommended this box always remained checked. Note that resetting the IC when the cell is not relaxed causes a temporary fuel gauge error.

Read/Write Register

The user can read a single register location by entering the address in hex and clicking the **Read** button. The user can write a single register location by entering the address and data in hex and clicking the **Write** button. The read loop is temporarily paused each time to complete this action.

Save and Restore

The EV kit software periodically saves the values from registers related to cell characteristics that change over time. These values are then restored into an IC after reset so that the fuel gauge remains accurate as the cell ages. The software automatically performs a save operation every 64% of one cycle or when the software exits. The user can change the save interval or force a save operation at any time by clicking the **Save** button. To restore this information after the IC has been power cycled or reset through software, click the **Restore** button.

Component Suppliers

SUPPLIER	PHONE	WEBSITE
Murata Electronics North America, Inc.	770-436-1300	www.murata.com/en-us
TDK Corp.	847-803-6100	www.component.tdk.com
Vishay	402-563-6866	www.vishay.com

Note: Indicate that you are using the MAX17055 when contacting these component suppliers.

Ordering Information

PART	TYPE
MAX17055GEVKIT#	EV Kit (for TDFN)
MAX17055XEVKIT#	EV Kit (for WLP)

#Denotes RoHS compliant.

MAX17055G EV System Bill of Materials

PART	QTY	DESCRIPTION
C1	1	0.1uF ±10%, 16V X7R ceramic capacitor (0402)
C2	1	0.47uF ±10%, 16V X5R ceramic capacitor (0402)
R1, R3	2	0Ω resistor (0402)
R2	1	10kΩ ±1%, resistor (0402)
R4	1	0Ω resistor (0402), not populated
R5	1	0.010Ω ±1%, resistor (0805)
R6	1	0Ω resistor (0805), not populated
R8-R10, R12, R13	5	150Ω ±1%, resistor (0402)
R11	1	1KΩ ±1%, resistor (0402)
RT1	1	Thermistor 10K NTC (0402) Murata NCP15XH103F03RC
D1	1	Diode, LED Red (0603)
D2-D4	3	5.6V Zener Diode (SOD323)
J1-J8, J10	9	Plated through hole solder pad (16g wire)
J9	1	RJ-11,R/A,6-POSITION/6-CONTACTS
U1	1	MAX17055ETB+ Li+ fuel gauge IC 2x2.5 TDFN 10 pin
	1	PCB: MAX17055EVKIT
	1	USB-to-RJ11 board DS91230+
	1	RJ11 6pos-6pos reverse modular cord 6ft.

MAX17055G EV System Schematic

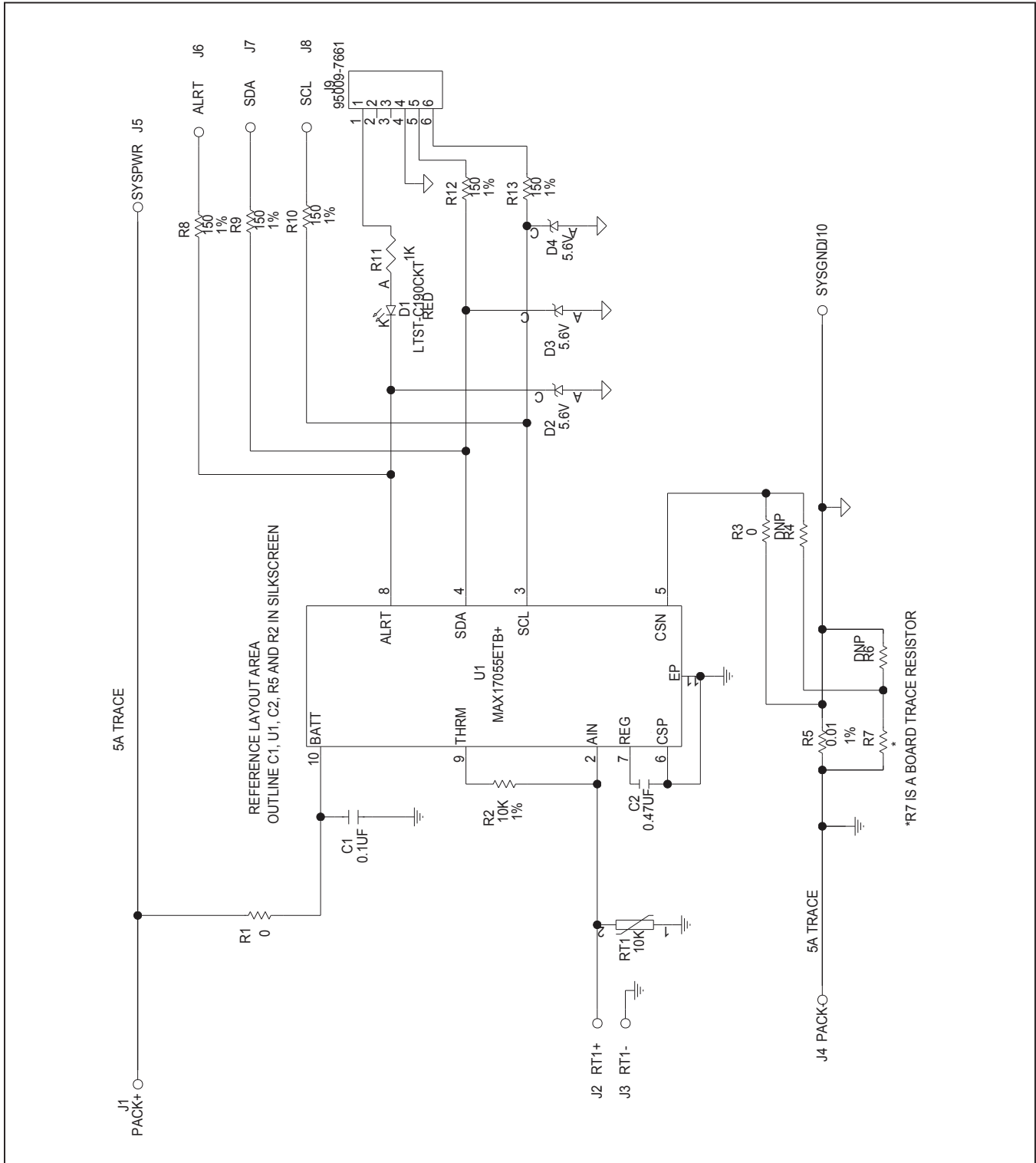

MAX17055G EV System PCB Layout

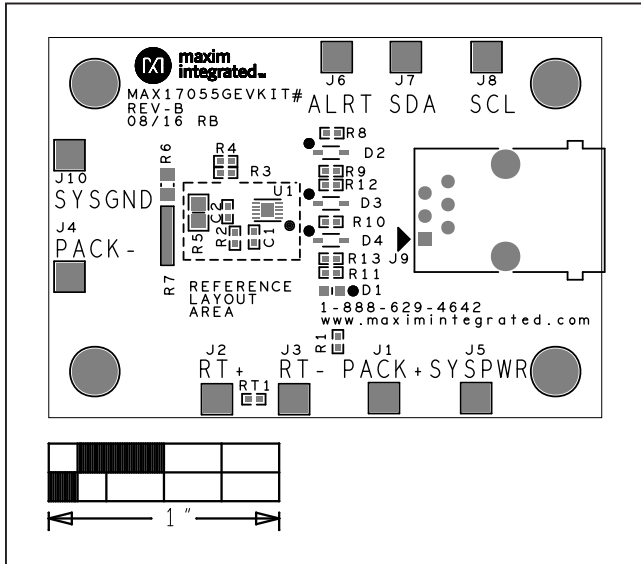

Component Placement

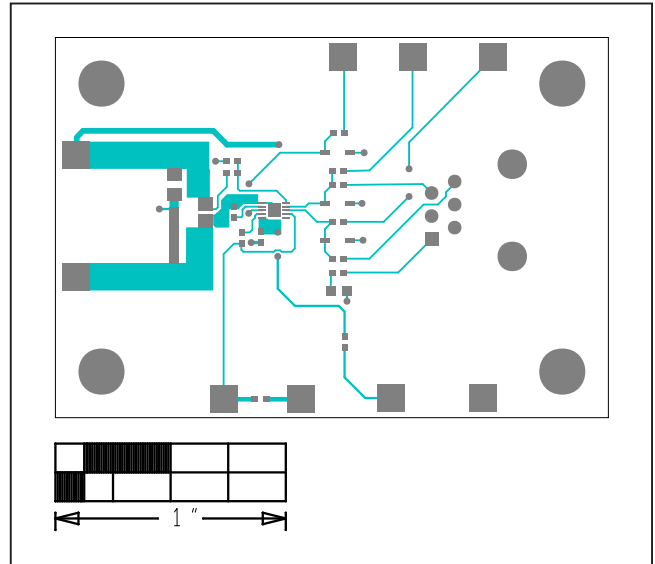

Top Layout

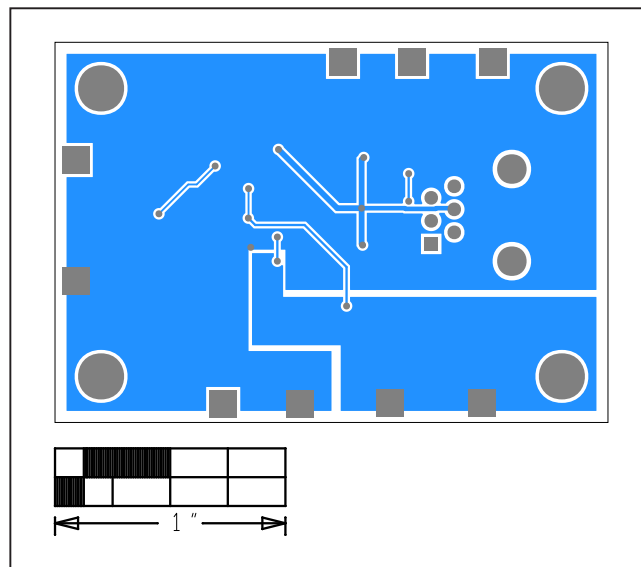

Bottom Layout

MAX17055X EV System Bill of Materials

PART	QTY	DESCRIPTION
C1	1	0.1uF ±10%, 16V X7R ceramic capacitor (0402)
C2	1	0.47uF ±10%, 16V X5R ceramic capacitor (0402)
R1, R3	2	0Ω resistor (0402)
R2	1	10kΩ ±1%, resistor (0402)
R4	1	0Ω resistor (0402), not populated
R5	1	0.010Ω ±1%, resistor (0805)
R6	1	0Ω resistor (0805), not populated
R8-R10, R12, R13	5	150Ω ±1%, resistor (0402)
R11	1	1KΩ ±1%, resistor (0402)
RT1	1	Thermistor 10K NTC (0402) Murata NCP15XH103F03RC
D1	1	Diode, LED Red (0603)
D2-D4	3	5.6V Zener Diode (SOD323)
J1-J8, J10	9	Plated through hole solder pad (16g wire)
J9	1	RJ-11,R/A,6-POSITION/6-CONTACTS
U1	1	MAX17055EWL+ Li+ fuel gauge IC WLP 9 pin
	1	PCB: MAX17055XEVKIT
	1	USB-to-RJ11 board DS91230+
	1	RJ11 6pos-6pos reverse modular cord 6ft.

MAX17055X EV System PCB Layout

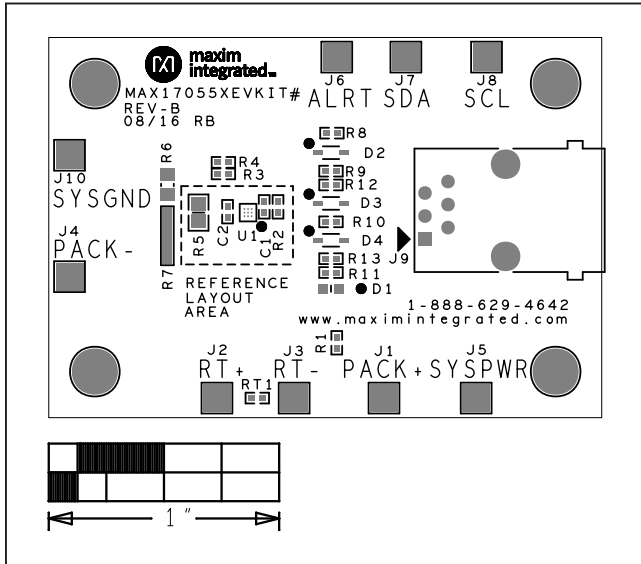

Component Placement

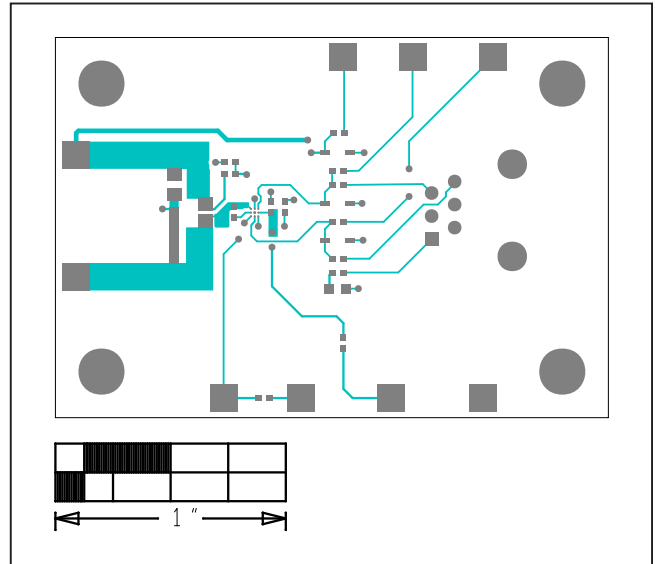

Top Layout

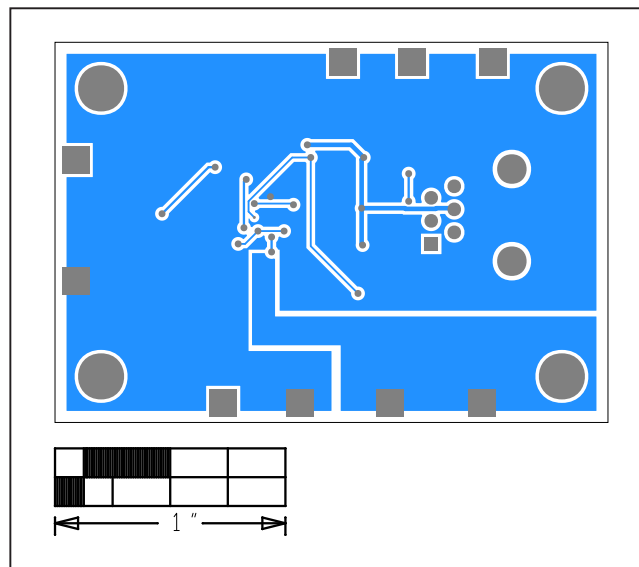

Bottom Layout

Revision History

REVISION NUMBER	REVISION DATE	DESCRIPTION	PAGES CHANGED
0	1/17	Initial release	—

For pricing, delivery, and ordering information, please contact Maxim Direct at 1-888-629-4642, or visit Maxim Integrated's website at www.maximintegrated.com.

Maxim Integrated cannot assume responsibility for use of any circuitry other than circuitry entirely embodied in a Maxim Integrated product. No circuit patent licenses are implied. Maxim Integrated reserves the right to change the circuitry and specifications without notice at any time.