

Crown race puller - 1614/4BI

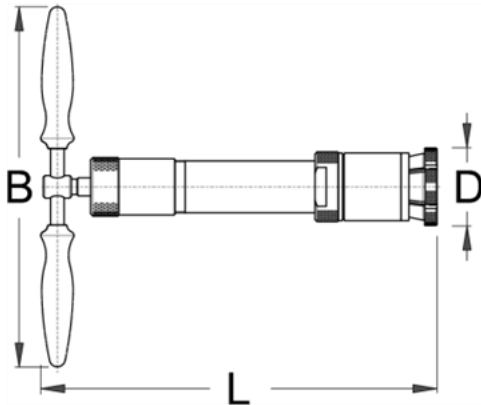

Description

- material: special tool steel, hardened and tempered
- surface finish: blacken to standard DIN 50938
-

How to use the tool:

• The puller is a tool for quickly and precisely removing the headset crown race from 1", 1-1/8", 1-1/2" or 1-3/4" suspension or rigid front fork. To use, place the puller bush onto the front fork race and fix it by turning the nut. Turn the spindle attached to the steering column to pull the crown race from the fork. The product enables efficient race removal without the use of a hammer. It is intended for both professionals and enthusiasts.

Technical Data

Barcode	D	D	D	Length	B	Weight	Material	Accessories	Notes
62019 5	1"	1.1/8"	1.1/2"	351	320	3510	1F	1	-

Packaging data

Barcode	D	Retail tool packaging			Weight	Material	Transport package		
		Retail packaging in mm (length)	Retail packaging in mm (width)	Retail packaging in mm (height)			Transport packaging in mm (length)	Transport packaging in mm (width)	Transport packaging in mm (height)
62019 5	1"	405	395	60	3580	1	-	-	-