



Evaluation Boards for ADF7021 ISM Band Transceiver

Preliminary Technical Data

EVAL-ADF7021DBZX

FEATURES

ADF7021 ISM Band Transceiver Radio module
 Can plug into basic mother board (EVAL-ADF70XXMBZ) or development platform with embedded microcontroller (EVAL-ADF70XXMBZ2)
 RF daughter-card designed on low-cost 2-layer PCB as reference design for cost-sensitive applications
 Combined output matching circuit (no external antenna switch) optimized at several different frequency ranges
 Software programmable modulation schemes;
 GFSK/ FSK/ MSK/3FSK/ RC3FSK /4FSK/RC4FSK
 PC Software for Register Programming

GENERAL DESCRIPTION

The ADF7021 is a 2FSK/3FSK/4FSK transceiver that is designed for operation in the licensed and unlicensed VHF/UHF bands from 80MHz to 940MHz. There are different versions of the evaluation daughter board available, each optimized for different frequency bands, see Table 1. The daughter-board contains all the required components for operation of the radio, including loop filter, output matching, antenna and connector to mother board.

To control the ADF7021 via the PC you will need the EVAL-ADF70XXMBZ2 mother board. This technical note describes usage with the EVAL-ADF70XXMBZ2 boards (PCB RevD and higher). This is a multi-function board that can be used for:

- Detailed evaluation and RF testing of the parts.
- Running the ADIismLINK protocol to evaluate the ADF7xxx performance in a networked environment, perform range testing and Packet Error Rate (PER) tests
- Run the low-level device drivers, to perform timing critical tests or simply to patch into existing firmware.

Table 1: Ordering Codes

Board Number	RF Band	Rx Data Rate	Tx Data Rate	Loop Bandwidth
EVAL-ADF70XXMBZ ¹	Not for new Designs	-	-	-
EVAL-ADF70XXMBZ2	Recommended	-	-	-
EVAL-ADF7021DBZ2	862 MHz - 870 MHz	Up to 25 kbps	Up to 25 kbps	90 kHz
EVAL-ADF7021DBZ3	431 MHz - 470 MHz	Up to 25 kbps	Up to 25 kbps	90 kHz
EVAL-ADF7021DBJZ	426 MHz - 429 MHz	Up to 25 kbps	Up to 25 kbps	90 kHz
EVAL-ADF7021DBZ6	608 MHz - 614 MHz	Up to 25 kbps	Up to 25 kbps	90 kHz
EVAL-ADF7021DBZ5	RF Match/Loop filter not inserted	-	-	-

1. Simple mother board for direct register programming using parallel port interface. **Not recommended for new designs.**

Rev. Pr B

Information furnished by Analog Devices is believed to be accurate and reliable. However, no responsibility is assumed by Analog Devices for its use, nor for any infringements of patents or other rights of third parties that may result from its use. Specifications subject to change without notice. No license is granted by implication or otherwise under any patent or patent rights of Analog Devices. Trademarks and registered trademarks are the property of their respective companies.

One Technology Way, P.O. Box 9106, Norwood, MA 02062-9106, U.S.A.
 Tel: 781.329.4700 www.analog.com
 Fax: 781.326.8703 © 2007 Analog Devices, Inc. All rights reserved.

TABLE OF CONTENTS

Hardware Description.....3

ADF70XX Configuration Software Description.....4

Getting Started with the ADF7021.....5

Setting up an RF Link using ADIismLink.....7

Installing the USB drivers for the EVAL-ADF70XXMBZ2 board..... 10

Bill of Materials..... 15

Schematics 21

HARDWARE DESCRIPTION

The RF module, which is plugged into the mother board, consists of the ADF7021 device, output matching circuit optimized for operation in a certain frequency band, harmonic filter, PLL loop filter, de-coupling and TCXO. This RF module provides a low-cost, optimally matched RF reference design which you can use as a starting point for your design. A low-cost BOM is achieved by using a 2-layer PCB, a TCXO, and a simple combined output matching circuit which eliminates the need for an external antenna switch.

Gerber files for the daughter board are available for download on the ADF7021 product page. Schematics of the daughter board and mother board are given in the Schematics Section..

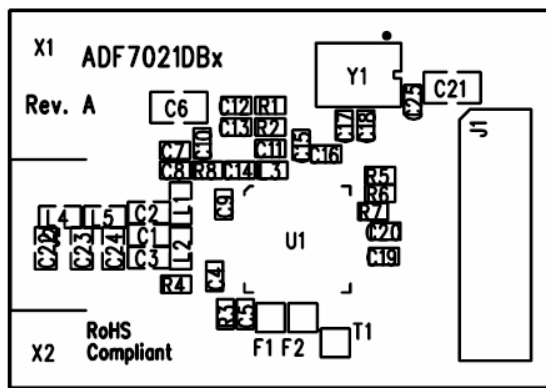

Figure 1. EVAL-ADF7021DBX silkscreen

The silk screen for the EVAL-ADF70XXMBZ2 mother board (applicable for versions Rev E and Rev F) is shown in Figure 2.

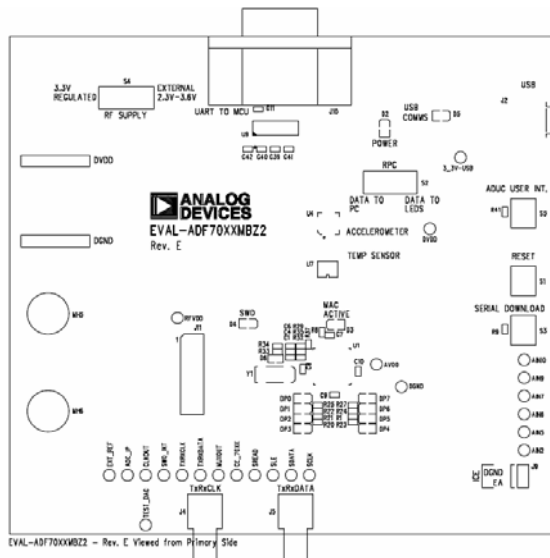

Figure 2. Mother Board Silkscreen – component side view

Power Supply Options

The MBZ2 board has several supply options. The simplest method is to simply supply the board with power from the USB cable. The 5V from the USB cable is regulated down to 3.3V for the microcontroller and radio board. It is possible to also supply the board with an external 5V - 9V supply (via J3) or a ½ AA battery. The MBZ2 kit ships with a 3.6V ½ AA battery.

It is also possible to power the radio daughter board separately from the main mother board to measure the current being drawn by the radio only, or to test the radio across its supply range of 2.3V to 3.6V. This carry out these tests switch S4 to “External 2.3V – 3.6V” and connect the RF external supply into the banana sockets, J6 (RF_PWR) and J7 (GND), on the underside of the board. Connections I-IN and I-OUT of connector J6 (between banana sockets J7) should be shorted unless the current drawn by the RF daughter card is to be measured, in which case a multimeter should be connected between I-IN and I-OUT.

Data Interface (TxRxData, TxRxCLK, INT, CE)

TxRxData and TxRxCLK are both brought out on SMAs. This allows you to either input Txdata view or else view the demodulated data on a oscilloscope or connect into a Bit Error Rate tester. These two pins are connected into the SPI interface of the on-board microcontroller (ADuC847).

CE is a hardware reset pin for the ADF7021 and can be controlled from the ADI configuration software. These pins are also brought out as test points.

Configuration Interface (SDATA, SCLK, SLE, SREAD)

The configuration interface on the ADF7021 is connected to GPIO on the ADuC847 microcontroller which bit-bangs the ports to configure the ADF7021 device. These four configuration pins are also brought out as test points. Low level device drivers are available on the analog.com website as example code of how to interface and configure to the ADF7021 device.

ADF70XX CONFIGURATION SOFTWARE DESCRIPTION

Before using the MBZ2 board you should run the “ADF7xxx_ADlismLINK Install” which contains the relevant USB drivers and setup files for the EVAL-ADF70XXMBZ2. This needs to be done before plugging in the hardware. See [Installing USB Drivers](#) section for details.

The ADF7021 configuration software and the network demo software, ADlismLINK, are also installed as part of the install process. You should check the Analog Devices Website periodically for updates. <http://www.analog.com/srd>

Once the programs have installed, run ADF7021Rev3_1.exe (or later) from the Analog Devices folder in the Start menu. The window shown below in Figure 3 should appear – you will need a screen resolution of 1024 x 768 to use the program.

This is the main window and is divided up into several sections some of which have their own sub-windows which are indicated by a raised button. For example in the PLL Options section, you enter the sub-window by clicking on the “Synth Settings...” button. The green and red toggle buttons turn a feature on or off. You can use the software in stand-alone

mode, that is with the hardware unconnected to calculate register values for example. In this mode the USB button at the bottom of screen should read ‘Connect USB’ and should not be clicked. However in most cases you will want to use the software to control the ADF7021 device. After opening the software, simply click on ‘Connect USB’. Once the software has connected to the target board, the button should change to “Disconnect USB”. The USB comms is now initiated and you should be able to communicate with the device using the software. The software also supports the EVAL-ADF70XXMBZ which uses the parallel port interface.

The software eases the programming challenge by allowing you to input your desired RF frequency, modulation scheme, data-rate etc. and then auto-calculating the ADF7021 register settings based on these inputs. The calculated register settings are displayed in the “Update Registers” panel.

For direct programming of the ADF7021, click on the “Manual Register Edit” button. This allows you to enter Hex values into individual registers. This is useful for debugging the register settings that you will use in your program code.

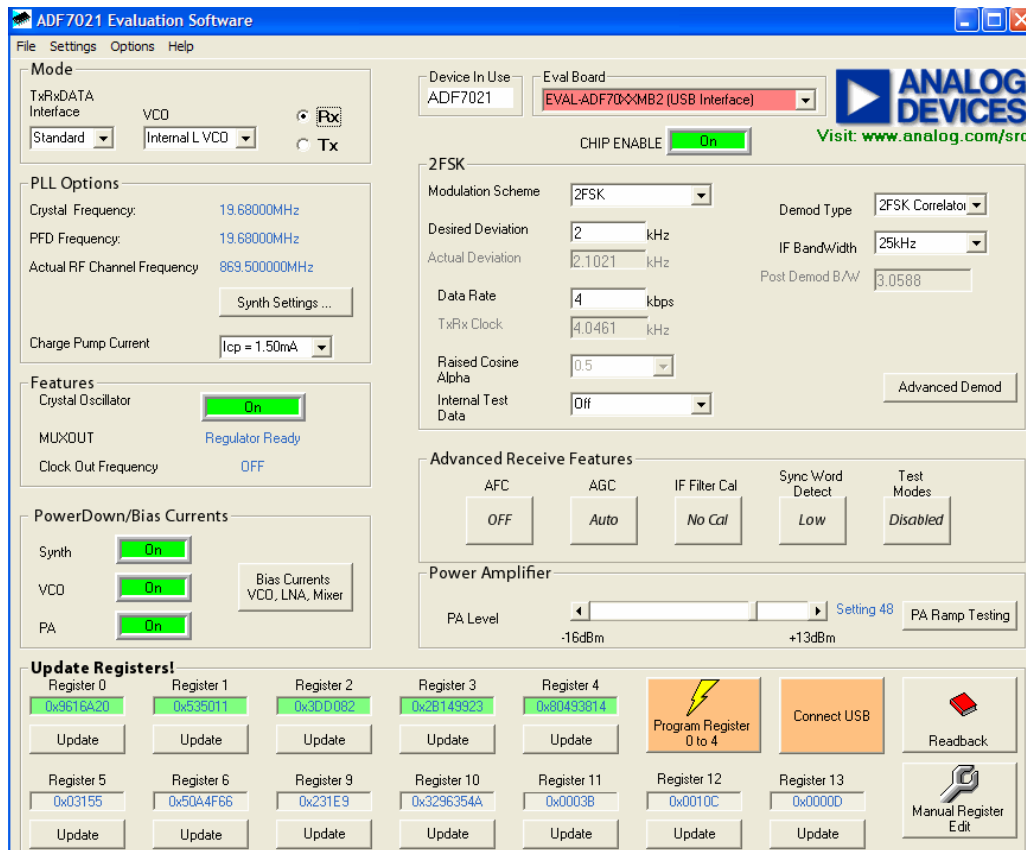

Figure 3. Software Front Panel Display

GETTING STARTED WITH THE ADF7021

The evaluation performed will be specific to each application, but this section will enable users to familiarise themselves with the features of the ADF7021.

Before plugging in the hardware please run “ADF7xxx_ADIismLINK Install”, which contains the necessary USB drivers and dlls! Note if you have installed ADIismLINK Rev1.0 previously you should also run “purge_ADIism_LINK.bat” to remove the old USB setup from the registry.

Initial Hardware Setup

As described in the Hardware Description section, the evaluation board is divided into two; an RF module containing the ADF7021 and a mother-board which accepts the RF module and contains the power supply block, analog microcontroller, USB bridge and some I/O pins. You need to mount the RF module onto the mother-board, ensuring correct alignment by having the drill-holes in the module above the supports on the mother board.

There are various power supply options on the board, including the option to power the RF separately to measure RF_IDD and also operate the radio over its full voltage range from 2.3V to 3.6V. The simplest way to power the board is to simply connect the USB cable which provides 5V from the host pc. Setting switch S4 (RF supply) to “3.3V regulated” will ensure the daughter board is powered from this supply also.

Communicating to the Hardware and simple debug

To allow register programming of the ADF7021, click on ‘Connect USB’. Once the software has connected to the target hardware, the button should change to “Disconnect USB”.

You will now be able to communicate with the device. To check this you should click on the Readback button and select silicon revision. If you are communicating with the target board and the radio module is plugged in, you should readback a valid code which is then displayed on the top-right of the front panel. A valid readback code is 0x2104.

Other useful debug modes to check before proceeding onto the main Tx and Rx evaluation are checking CLKOUT operation on an oscilloscope. By default the CLKOUT frequency should be XTAL/8. You can change this value in the software. Another useful debug point is the voltage on the Regulator pins. This should be approximately 2.2V, when CE is active. You can check this by probing the top of C5 (VREG4 pin) on the RF module.

Evaluating the ADF7021 in Rx and Tx modes

Before setting up an RF link, it is usually informative to evaluate the ADF7021 in either Tx mode or Rx mode. The typical setup for this is shown in Figure 4 and Figure 5. To select between Tx and Rx modes in the software select the required mode in the top left of the front display panel.

Note: Some of the ADF7021 daughter boards use a TCXO frequency other than 19.68MHz. In the following text for simplicity it will be assumed that the crystal/TCXO is 19.68MHz.

Test Procedure for the ADF7021 in Tx Mode

With the USB cable connected use the setup as shown in Figure 4.

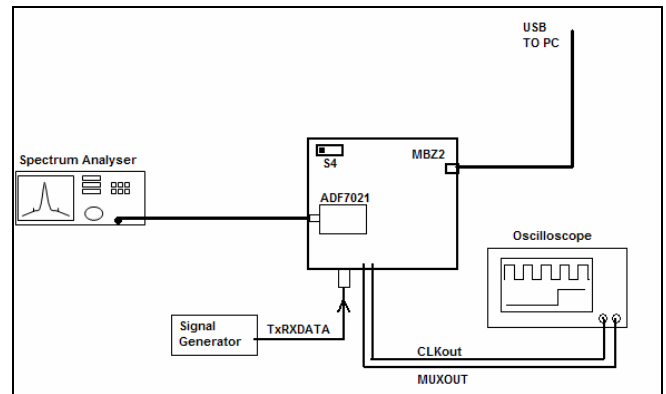

Figure 4. Evaluation board setup for Tx mode

1. Using the ADF7021 Software, setup the following Tx parameters:
 - a. If using the external inductor VCO set the VCO to “External L VCO” in the Mode sub-section (top left). Otherwise leave it as “Internal L VCO”.
 - b. Ensure Tx Mode is selected in Mode sub-section.
 - c. Click on Synth Settings and set
 - i. RF Channel Frequency to your desired frequency.
 - ii. You can also toggle the VCO divide-by-2 button to get half this frequency (when using External L VCO). This divider is placed outside the PLL loop and thus does not affect the N-Divider settings.
 - iii. Ftcxo = 19.68MHz
 - iv. FPFd = 19.68MHz
 - v. Hit Calculate and Return to Front

Panel.

d. Modulation Options

- i. Select 2FSK
- ii. Set Internal Test Data to “Tx Carrier”
- iii. Using slide-bar change the power setting to 48.

2. Hit the Program Registers 0-4 Button on the Software. This will program the registers using the correct power up sequence as outlined in the ADF7021 datasheet.
3. Examine the output using the spectrum analyser. The output should be locked to the programmed output frequency and the output power should be approximately +10dBm. There will be some small error in the TX frequency due to the TCXO error but this should be <500Hz. You can adjust the output power using the output power slide-bar in the software.
4. Re-enter the Synth Settings sub-window and change the output frequency and verify it covers your required frequency range.
5. In-band Phase Noise is measured by narrowing the span on the spectrum analyser to 10kHz and turning Marker Noise ON. A typical measurement for 0dBm output power is -94dBc/Hz at 5kHz offset. ADI SRD Design Studio will help you predict the expected phase noise numbers.
6. You can now apply modulation to the TxDATA pin using an external data generator connected to the TxRxDATA SMA. This will allow you to monitor spurious, adjacent channel power and harmonic levels. Alternatively you can select the “Tx PN9 sequence” from the Internal Test Data pull-down menu which uses an internal PN9 pattern generator to modulate the RF carrier.

architecture where the IF is operating at 100kHz. This means the LO frequency should be set to 100kHz below the incoming RF frequency. The ADF7021 software takes care of this automatically for you.

7. Setup your signal generator to output an FSK signal at the desired frequency, and -70dBm level. Select the data-rate (9.6kbps) and deviation frequency (2.4kHz). Set the data modulation to 1010 data.
8. Using the ADF7021 software, setup the following Rx parameters:
 - a. Ensure Rx Mode is selected in Mode sub-window
 - b. In Synth Settings select the RF Frequency to the signal generator Output frequency. The LO will automatically be programmed to RF - 100kHz.
 - c. Modulation Options
 - i. Select 2FSK Modulation
 - ii. Set Desired Deviation = 2.4kHz
 - iii. Set Data-Rate = 9.6 (kbps)
 - iv. Set Demod Type = Correlator
 - v. Set IF Bandwidth = 25kHz

9. Hit the Program Registers 0-4 Button on the Software
10. Click on the IF Filter cal button. This will open the IF filter cal window. Click the “Do Coarse cal” button. This will automatically perform an IF Filter coarse calibration (which is recommended on every power up in rx mode).
11. Using the scope, probe the TxRxData pin and TxRxCLK. They should be 3V p-p square-waves with frequencies of 4.8kHz (i.e. 1010 data at 9.6kbps) and 9.6kHz respectively. Ensure that these square-waves are triggered correctly and are not flickering.

12. If you don't have a built-in BER tester you can estimate the sensitivity point, by reducing the level on the frequency generator until you see the TxRxData waveform 'flickering' which corresponds to errors in the received data. Typically if you see a flicker/error once per second you can roughly estimate this to be the sensitivity point. Note the level on the Signal Generator when this happens. For this setup it should be -113dBm +/- 2dBm.

Test Procedure for the ADF7021 in Rx mode

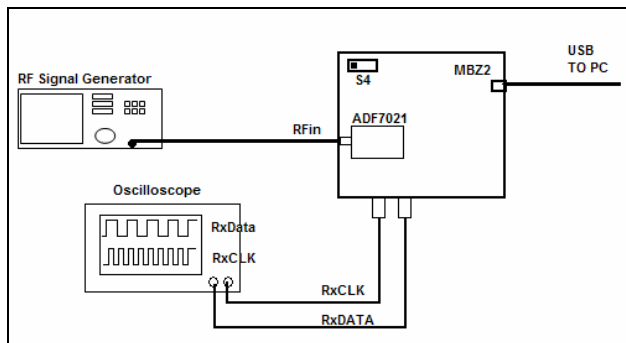

Figure 5. Evaluation board setup for Rx mode

With the USB cable connected use the setup as shown in Figure 5. It is important to note that the ADF7021 uses a low-IF

Readback Function

It is possible to enable the on-chip ADC on the ADF7021 and readback a selection of parameters, including battery voltage, temperature (from the on-board temperature sensor), Frequency Error, External voltage and RSSI.

To activate this feature, click on the Readback Toggle button. In the sub-window select the type of readback required. The appropriate value should be displayed on the screen. In Tx mode the ADC is powered-off by default to save power, so in order to readback correctly you need to enable the ADC. This can be done by clicking the status button in the ADC Status section to “ON” before clicking the Readback button. Since the ADC is used in Rx mode for the AGC function, the ADC is powered-on by default in this mode. Thus in Rx mode, valid battery voltage, temperature, frequency error and external voltage readback data are not possible.

In practical cases the user would typically do a battery voltage readback in Tx mode or in low-power measure mode. Low-power measure mode is entered by simply bringing CE high, enabling the ADC in Register8, selecting the desired readback value in Register7 and performing the readback.

SETTING UP AN RF LINK USING ADIISMLINK

The ADIismLINK software is the simplest way to setup an RF Link. This allows you to perform several functions:

- Setup a wireless star-network and send back sensor data (temperature/accelerometer or user defined) to the basestation to be displayed or logged on the pc.
- transmit simple text messages from Base Station node to remote nodes and vice versa.
- Transmit temperature data using the temperature sensor (TMP36) or tilt (pitch and roll angle) data using the accelerometer (ADXL322).
- Run a Packet Error Rate (PER) test to test link quality
- Perform range tests
- Develop user applications on top of the example PHY/MAC layer (Frequency hopping and duty-cycle MAC options)

Refer to the ADIismLINK User Guide and Manual for more information on using ADIismLINK.

ADF7021DBX BOARD OPTIMISATION

Output Matching Circuit

The ADF7021 exhibits optimum performance in terms of sensitivity, transmit power, and current consumption, only if its RF input and output ports are properly matched to the antenna impedance. For cost-sensitive applications, the ADF7021 is equipped with an internal Rx/Tx switch, which facilitates the use of a simple combined passive PA/LNA matching network as outlined in Figure 6. Please refer to the ADF7021 Datasheet or Application note AN- 859 for more details.

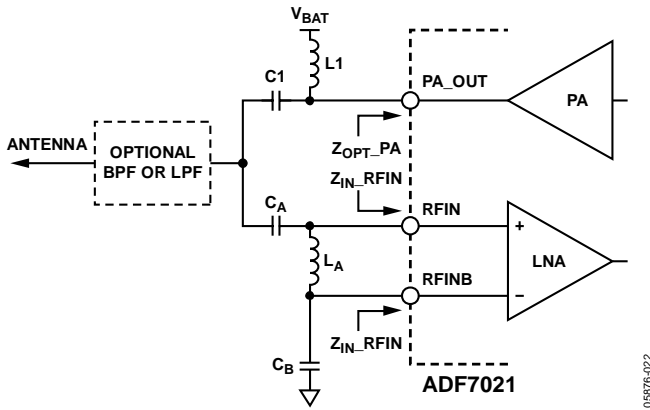

Figure 6. LNA/PA Output Matching Circuit

Choice of Inductor if using External L VCO

The ADF7021 can use either the internal inductor VCO or the external inductor VCO to set the operating frequency range of the device. The available frequency range with either choice is given in given in Table 2.

RF Output Frequency		VCO	RF Divide-by-2
Minimum (MHz)	Maximum (MHz)		
160	650	External L	Disabled
80	325	External L	Enabled
862	950	Internal L	Disabled
431	475	Internal L	Enabled

Table 2. ADF7021 Frequency Ranges for internal/External VCO Inductor and Divide-by-2 Enabled/Disabled

If the external VCO inductor is selected in Register 1 then the user has to choose the correct inductance value to set the operating frequency.

The length of the PCB track to the external inductor pad will need to be accounted for. The ADF7021 VCO Frequency range vs. external inductor value as measured on the EVAL-ADF7021DBX boards is shown in Figure 7. If you are using a different length of PCB track to the ADI Evaluation boards you need to take this into consideration in your design. It is estimated that the ADF7021 evaluation board track inductance is 2.6nH in total.

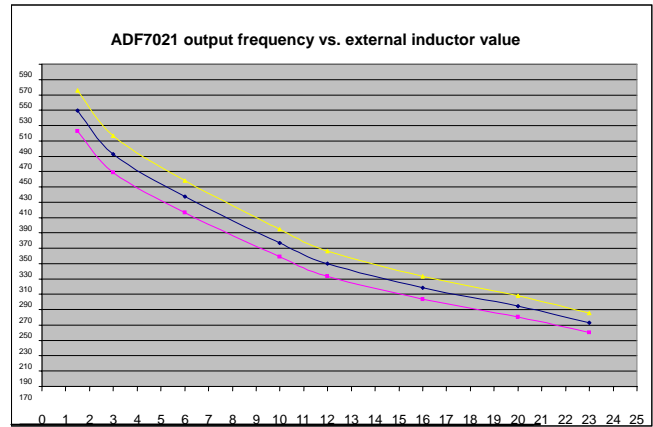

Figure 7. Direct Output Frequency vs. External Inductor Value(L3)

Checking VCO Tuning Range when using External L VCO

The VCO input range is 0.2V to 2.1V so the VCO is centered when the VCOIN voltage is ~1.1V. You can monitor this voltage by probing the VCOIN pin. It is also possible to shift the frequency and hence VCOIN voltage by use of the VCO Adjust bits.

Setting PLL Loop Bandwidths

The PLL Loop bandwidth on all of the ADF7021DBZX daughter boards is typically 90-110kHz at a charge pump current of 1.5mA. This loop bandwidth provides optimum phase noise performance and thus adjacent channel power and occupied bandwidth performance in Tx mode and interference rejection in Rx mode.

If the EVAL-ADF70XXDBZ5 board is being used it is likely that you are designing for a non-standard RF frequency. In this case we recommend using our freely available tool, SRD Design Studio (see www.analog.com/srd), to design the loop filter and aid in other system design aspects.

IF Filter

The IF Filter response can be viewed on a SA by AC coupling either test point F1 or F2 pf the ADF7021 to the Spectrum Analyser as shown in Figure 8.

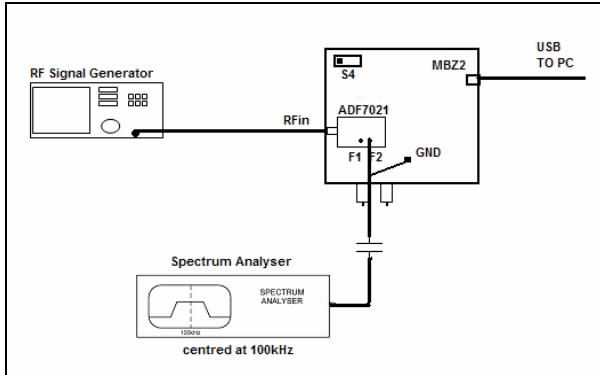

Figure 8. Setup for viewing IF Filter response

Using an External Reference Frequency

During evaluation it may be necessary to use a signal generator instead of a crystal/TCXO for debug or evaluation purposes.

To allow this simply remove capacitor C18 from the ADF7021 daughter board and place a 100pF capacitor at C17. The external signal source can then be connected to the EXT_REF test point on the MBZ2 mother board.

Analog RSSI

For debug of your design it may be useful to look at the analog RSSI. This can be enabled in the software under Test Modes and ticking “Analog RSSI”. The analog RSSI signal is then available on the daughter board test point T1.

Test DAC Output

The ADF7021 provides access to the 2FSK/3FSK/4FSK demodulator output to facilitate external measurement of functions such as demodulator output SNR, receiver eye-diagram analysis, and analog FM demodulation. For these measurements, access to the digital FSK demodulator output is achieved by using an on-chip $\Sigma\Delta$ (SD) modulator in conjunction with an external, passive RC network. This network provides an analog output signal (test DAC output) to replicate the output of the on-chip digital FSK demodulator.

Refer to Application Note AN-852 for information on setting up and using the Test DAC.

Figure 9 shows the Test DAC RC filter connections. To allow

use of the Test DAC the following modifications need to be made to the mother board:

- Populate R40 with a zero ohm link
- Populate R43 with a 660 ohm resistor.
- Remove R39. This is necessary in order to disconnect the SWD line from the MCU interrupt pin. If the user wishes to use ADIismLINK at some stage then this resistor will have to be re-populated (100ohm) as the ADIismLINK protocol needs the SWD interrupt.

The RC filter components R44, R45, C36, C37 and C38 are already populated. This will provide adequate filtering for datarates between 1kbps and 4.8kbps.

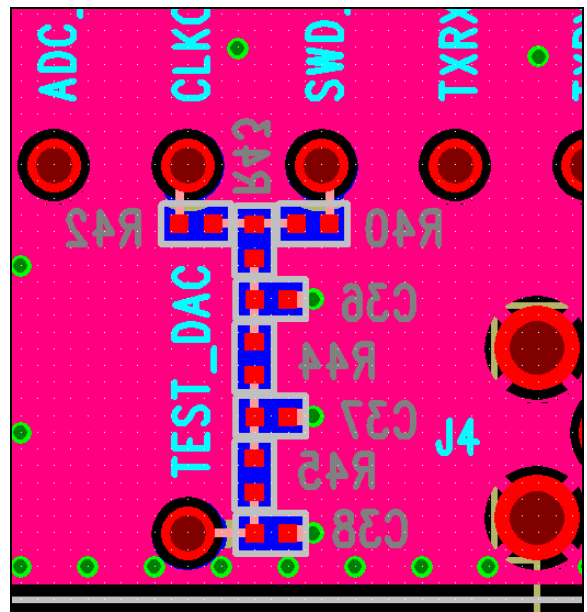

Figure 9. Underside of EVAL-ADF70xxMBZ2 board showing Test DAC connections

INSTALLING THE USB DRIVERS FOR THE EVAL-ADF70XXMBZ2 BOARD

System Requirements

- Microsoft Windows 2000 or XP
- One available USB port (preferably USB2)

Driver files

The files required to install the UDB driver are:

- CyUSB.sys – the Cypress generic USB driver
- ADF7020DK2.inf – the setup information file
- ADF70xxDK2.spt – the EZ-USB firmware (the last three digits of the filename represent the version)

Make sure you have these files available before plugging the board in for the first time.

Installing

The software “ADF7xxx_ADIismLINK Install” should be downloaded from the CD or analog.com website and installed on your pc before plugging in the hardware. This zip file contains the relevant USB drivers and firmware necessary for operation of the EVAL-ADF70XXMBZ2 board. Note if you have installed ADIismLINK Rev1.0 previously you should run “purge_ADIismLINK.bat” to remove the old USB setup from the registry.

1. Windows 2000

Plug in the EVAL-ADF70XXMBZ2 development board, the “**Found New Hardware Wizard**” will appear after a while, click “Next >”:



Choose “Search for a suitable driver for my device (recommended)” and click “Next >”. You will be asked where Windows should look for the driver files:

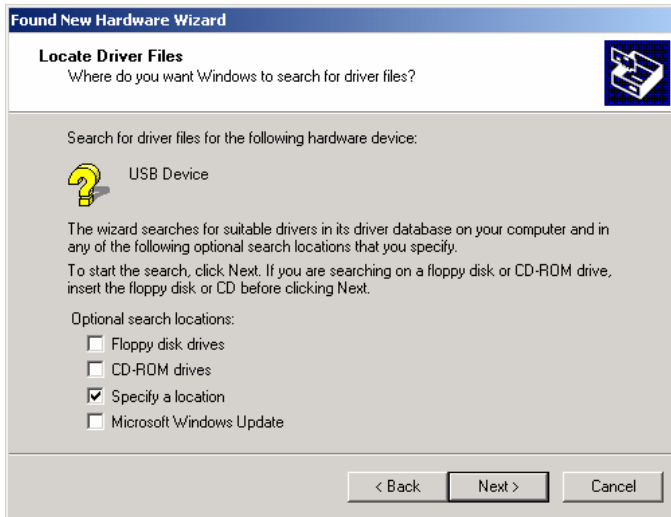

Make sure that **only** “Specify a location” is checked then click “Next >”. You will be prompted for the location of the driver files:



Browse to the directory where you put the driver files then click “OK”. The default path is C:\Program Files\Analog Devices BV\ADF7xxx Evaluation Software\USB Drivers. You will be told that Windows has found a driver:

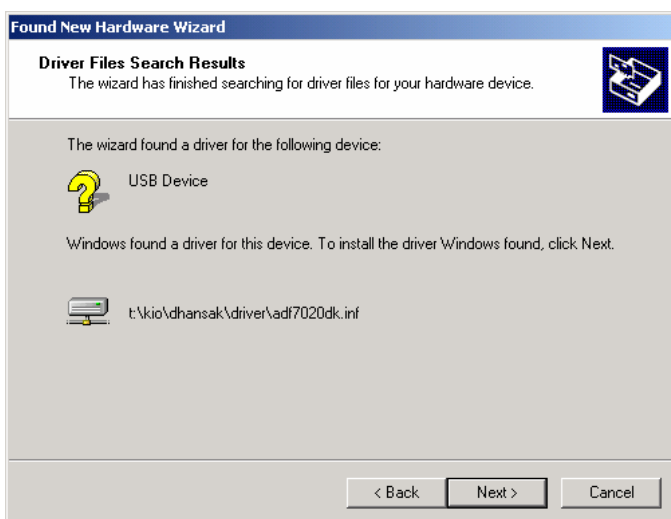

Click “Next >”. You will be told that the software is now installed:



Click "Finish". The EZ-USB firmware will now be loaded and the development will appear as a new device, Windows should find the driver for it automatically.

2. Windows XP

Plug in the MBZ2 development board, the "Found New Hardware Wizard" will appear after a while:



Choose "Install from a list of specific location (Advanced)" and click "Next >". You will be asked where Windows should look for the driver files:

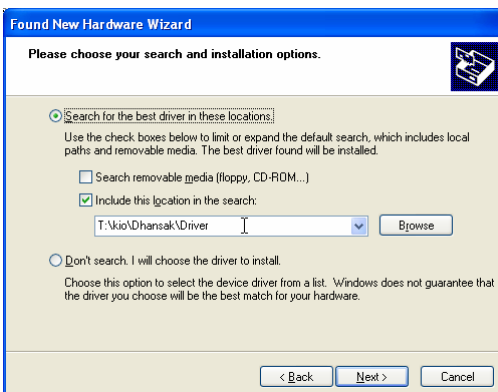

Choose "Search for the best driver in these locations", make sure "Search removable media" is **not** selected and that "Include this location in the search" is selected. Browse to the directory where you put the driver files then click "Next >". You will be informed that the driver has not passed Windows testing:



Click “Continue Anyway”. Once Windows has finished copying files and installing the driver you will be told that the wizard has completed:

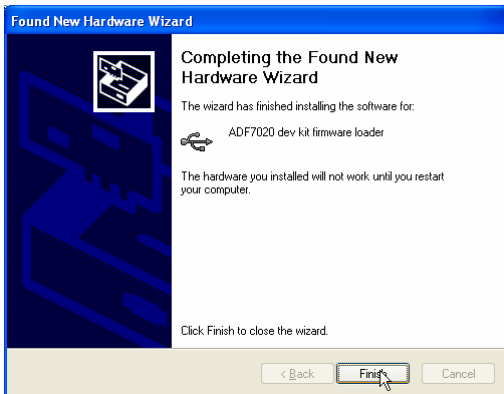

Click “Finish”. At this point the EZ-USB firmware will be loaded into the development kit and it will reappear as a different USB device, the “Found New Hardware Wizard” will pop up again:



Choose “Install from a list or specific location (Advanced)” then click “Next >”. You will be asked where Windows should look for the driver files:

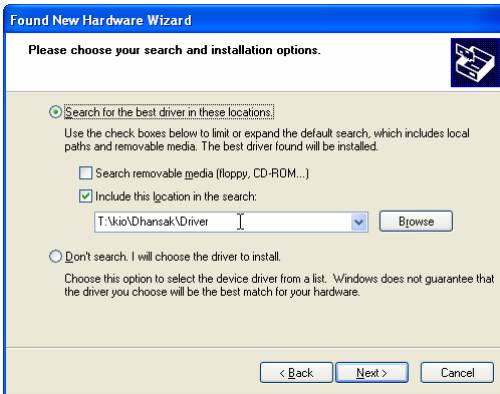

As before, choose “Search for the best driver in these locations” and “Include this location in the search”. Click “Next >”. You will be reminded that the driver has not passed Windows testing:



Click “Continue Anyway”. Once Windows has finished copying files and installing the driver you will be told that the wizard has completed:



Click “Finish”. You may be prompted to restart your computer:

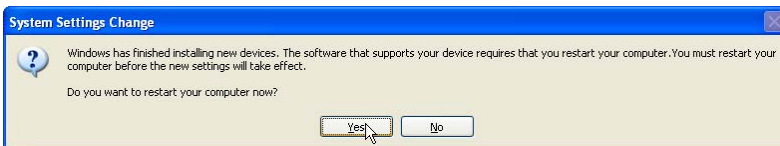

If this appears you should restart the computer before trying to use any of the software that depends on the USB driver (ADF7020, ADF7012, ADF7025, ADF7021).

BILL OF MATERIALS

Table 3. Bill Of Materials for the EVAL-ADF7021DBX Daughter Boards (Common to all versions)

Qty	Name	Value	Tolerance	PCB Decal	Manufacturing Part No.
6	C4, C7, C9, C16, C20, C25	10nF	±10%	0402	
1	C21	22uF	±10%	0805	
1	C6	10uF	±10%	0805	
1	C14	22nF	±10%	0402	
1	C8	220pF	±5%	0402	
4	C5, C10, C15, C19	100nF	±10%	0402	
1	C17	22pF	±5%	0402	
3	C18, C22, C24	Not Inserted		0402	
1	J1			HEADER14	
1	J2			SMA_EDGE_RF	
2	R5, R6, R7	1k	±5%	0402	
1	R3	3.6k	±5%	0402	
1	R4	1.1k	±5%	0402	
1	R8	3.9r	±5%	0402	
1	U1			LFCSP-48	ADF7021BCPZ

Table 4. Bill Of Materials for components specific to EVAL-ADF7021DBZ2 Daughter Board

Qty	Name	Value	Tolerance	PCB Decal	Manufacturing Part No.
Matching					
1	C1	2.7pF	±0.25pF	0402	GRM1555C1H2R7CZ01D
1	C2	8.2pF	±0.5pF	0402	GRM0225C1C8R2DD01D
1	C3	3.0pF	±0.25pF	0402	GRM1555C1H3R0CZ01D
1	L1	4.3nH	±5%	0402	Coilcraft 0402CS-4N3X-LU
1	L2	8.7nH	±5%	0402	Coilcraft 0402CS-8N7X-LU
VCO External Inductor					
	L3	Not inserted		0402	
Harmonic Filter					
1	L4	5.1nH	±5%	0402	
1	L5	6.8nH	±5%	0402	
1	C23	3.9pF	±5%	0402	
	C22	Not inserted			
	C24	Not inserted			
	C24	Not inserted			
TCXO					
1	Y1	19.68MHz	2.5ppm	5.0x3.2x1.3mm SMD	SIWARD TXO812025LJ-19.68MHz-3.0R
Loop Filter					
1	R1	270r	±10%	0402	
1	R2	560r	±10%	0402	
1	C11	1000pF	±10%	0402	
1	C12	15nF	±10%	0402	
1	C13	470pF	±10%	0402	

Table 5. Bill Of Materials for components specific to EVAL-ADF7021DBZ3 Daughter Board

Qty	Name	Value	Tolerance	PCB Decal	Manufacturing Part No.
Matching					
1	C1	4.7pF	±0.25pF	0402	GRM1555C1H4R7CZ01D
1	C2	10pF	±5%	0402	GRM1555C1H100JZ01D
1	C3	6.8pF	±0.5pF	0402	GRM1555C1H6R8DZ01D
1	L1	13nH	±5%	0402	Coilcraft 0402CS-13NX-JLU
1	L2	27nH	±5%	0402	Coilcraft 0402CS-27NX-JLU
VCO External Inductor					
1	L3	Not inserted		0402	
Harmonic Filter					
1	L4	22nH	±5%	0402	
1	L5	20nH	±5%	0402	
1	C23	6.8pF	±0.5pF	0402	
	C22	Not inserted			
	C24	Not inserted			
TCXO					
1	Y1	19.68MHz	2.5ppm	5.0x3.2x1.3mm SMD	SIWARD TXO812025LJ-19.68MHz-3.0R
Loop Filter					
1	R1	270r	±10%	0402	
1	R2	560r	±10%	0402	
1	C11	1000pF	±10%	0402	
1	C12	15nF	±10%	0402	
1	C13	470pF	±10%	0402	

Table 6. Bill Of Materials for components specific to EVAL-ADF7021DBJZ Daughter Board

Qty	Name	Value	Tolerance	PCB Decal	Manufacturing Part No.
Matching					
1	C1	4.7pF	±0.25pF	0402	GRM1555C1H4R7CZ01D
1	C2	10pF	±5%	0402	GRM1555C1H100JZ01D
1	C3	6.8pF	±0.5pF	0402	GRM1555C1H6R8DZ01D
1	L1	13nH	±5%	0402	Coilcraft 0402CS-13NX-JLU
1	L2	27nH	±5%	0402	Coilcraft 0402CS-27NX-JLU
VCO External Inductor					
1	L3	7.5nH	±1%	0402	Coilcraft 0402CS-7N5X-GLU
Harmonic Filter					
1	L4	11nH	±5%	0402	
1	L5	11nH	±5%	0402	
1	C23	12pF	±0.5pF	0402	
1	C22	8.2pF	±0.5pF	0402	
1	C24	8.2pF	±0.5pF	0402	
TCXO					
1	Y1	10MHz	2.5ppm	5.0x3.2x1.3mm SMD	SIWARD TXO812025LJ – 10.000000MHz – 3.0R
Loop Filter					
1	R1	1.1k	±5%	0402	
1	R2	2.4k	±5%	0402	
1	C11	270pF	±10%	0402	
1	C12	4.7nF	±10%	0402	
1	C13	120pF	±10%	0402	

Table 7. Bill Of Materials for components specific to EVAL-ADF7021DBZ5 Daughter Board

Qty	Name	Value	Tolerance	PCB Decal	Manufacturing Part No.
Matching					
1	C1	Not inserted		0402	
1	C2	Not inserted		0402	
1	C3	Not inserted		0402	
1	L1	Not inserted		0402	
1	L2	Not inserted		0402	
VCO External Inductor					
1	L3	Not inserted		0402	
Harmonic Filter					
1	L4	Not inserted		0402	
1	L5	Not inserted		0402	
1	C23	Not inserted		0402	
1	C22	Not inserted		0402	
1	C24	Not inserted		0402	
TCXO					
1	Y1	19.68MHz	2.5ppm	5.0x3.2x1.3mm SMD	SIWARD TXO812025LJ-19.68MHz-3.0R
Loop Filter					
1	R1	Not inserted		0402	
1	R2	Not inserted		0402	
1	C11	Not inserted		0402	
1	C12	Not inserted		0402	
1	C13	Not inserted		0402	

Table 8. Bill Of Materials for components specific to EVAL-ADF7021DBZ6 Daughter Board

Qty	Name	Value	Tolerance	PCB Decal	Manufacturing Part No.
Matching					
1	C1	2.7pF	±0.5pF	0402	
1	C2	8.2pF	±0.5pF	0402	
1	C3	3.9pF	±0.5pF	0402	
1	L1	10nH	±5%	0402	
1	L2	20nH	±5%	0402	
Harmonic Filter					
1	L4	19nH	±5%	0402	
1	L5	24nH	±5%	0402	
1	C23	3.9pF	±0.5pF	0402	
1	C22	n/c	±0.5pF	0402	
1	C24	n/c	±0.5pF	0402	
VCO External Inductor					
1	L3	1.8nH	±1%	0402	Coilcraft 0402CS-1N8X-GLU
TCXO					
1	Y1	19.2MHz	2.0ppm	5.0x3.2x1.3mm SMD	FOX914B-19.2 (Digikey 631-1063-1-ND)
Loop Filter					
1	R1	510r	±5%	0402	
1	R2	1.1k	±5%	0402	
1	C11	680pF	±10%	0402	
1	C12	10nF	±10%	0402	
1	C13	330pF	±10%	0402	

SCHEMATICS
EVAL-ADF7021DBZX Daughter Board

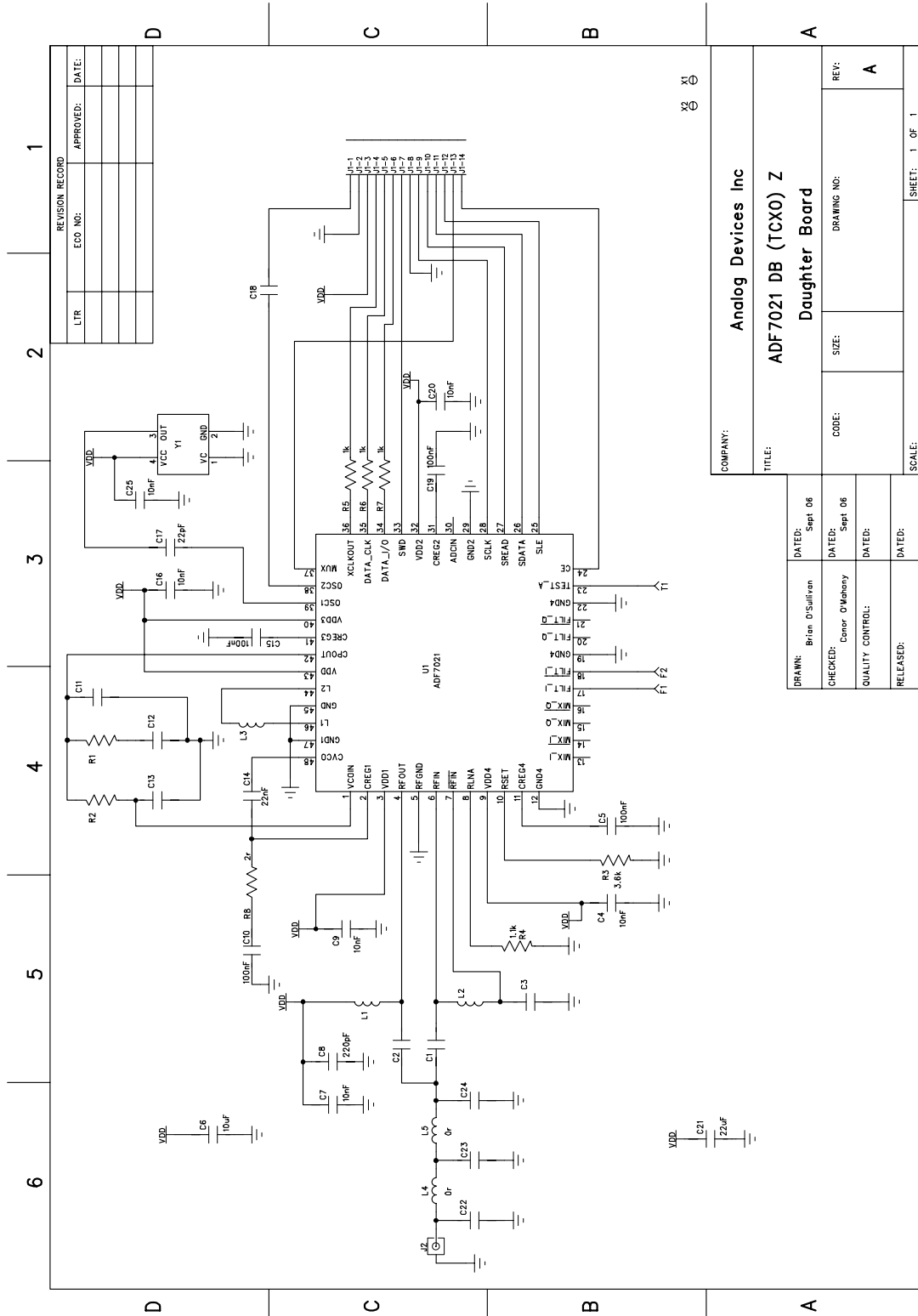

Figure 10. Schematic for EVAL-ADF7021DBZX daughter boards

ADF70XXMBZ2 Mother Board

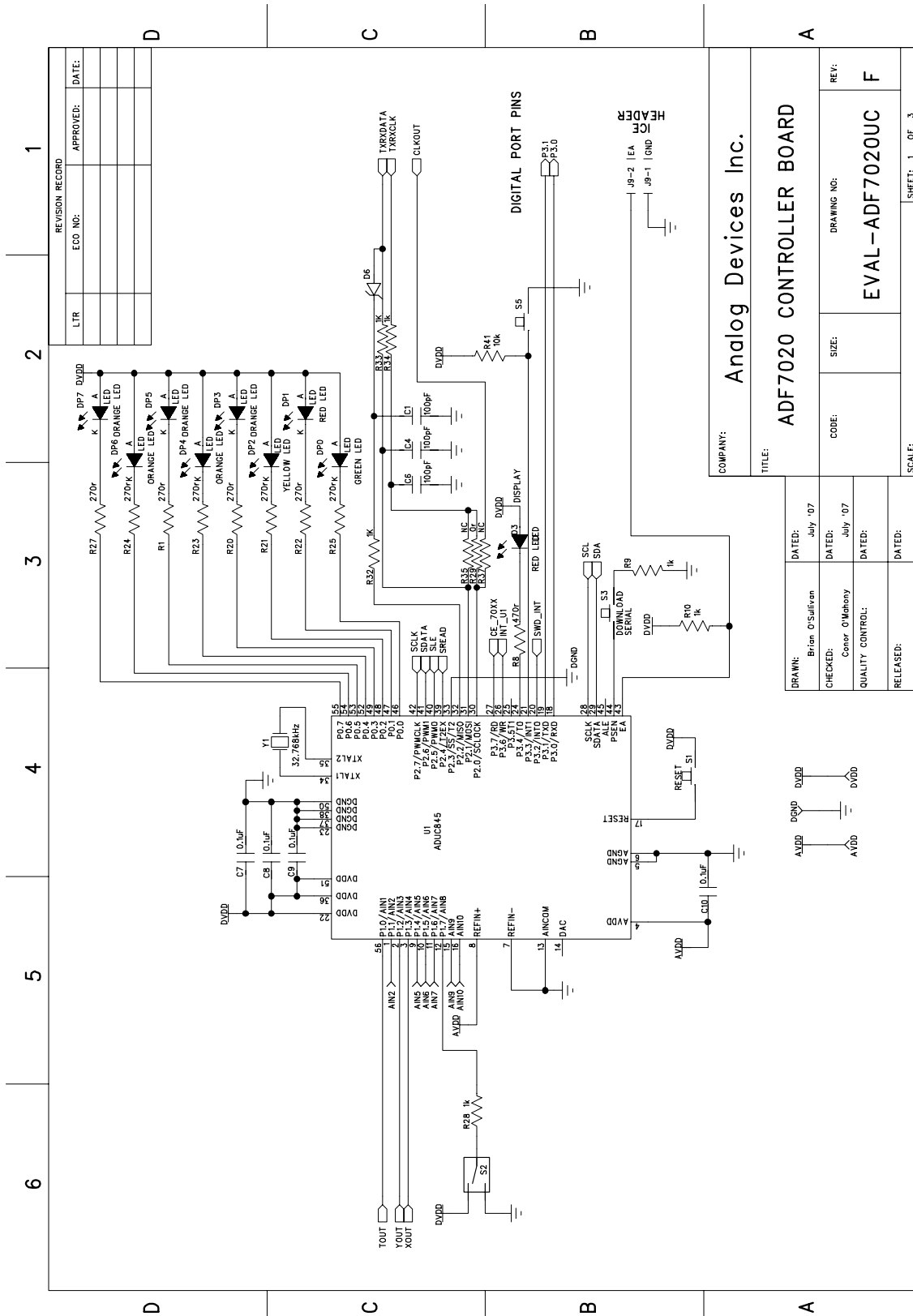

Figure 11. EVAL-ADF70XXMBZ2 Mother Board Schematic - MCU section

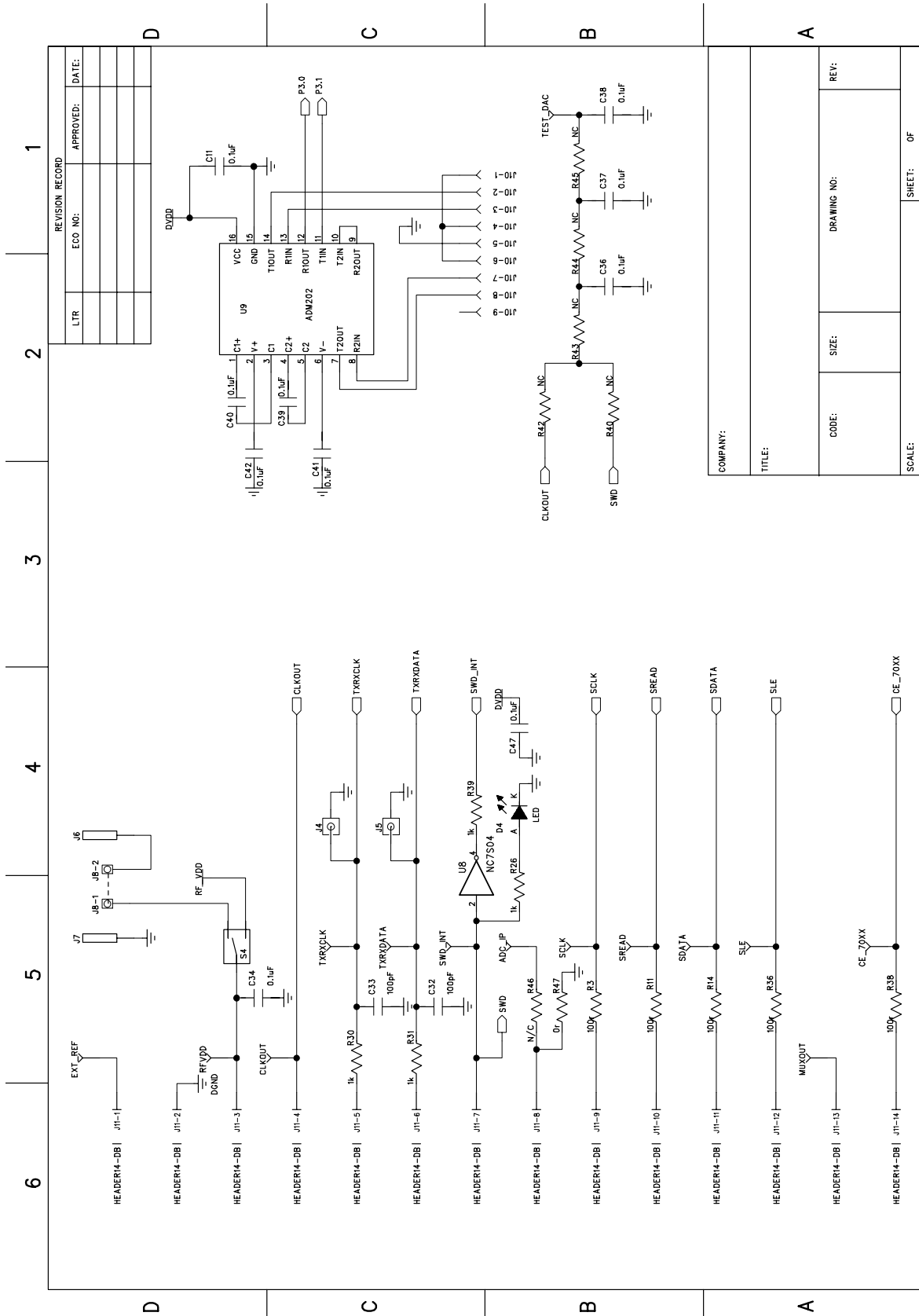
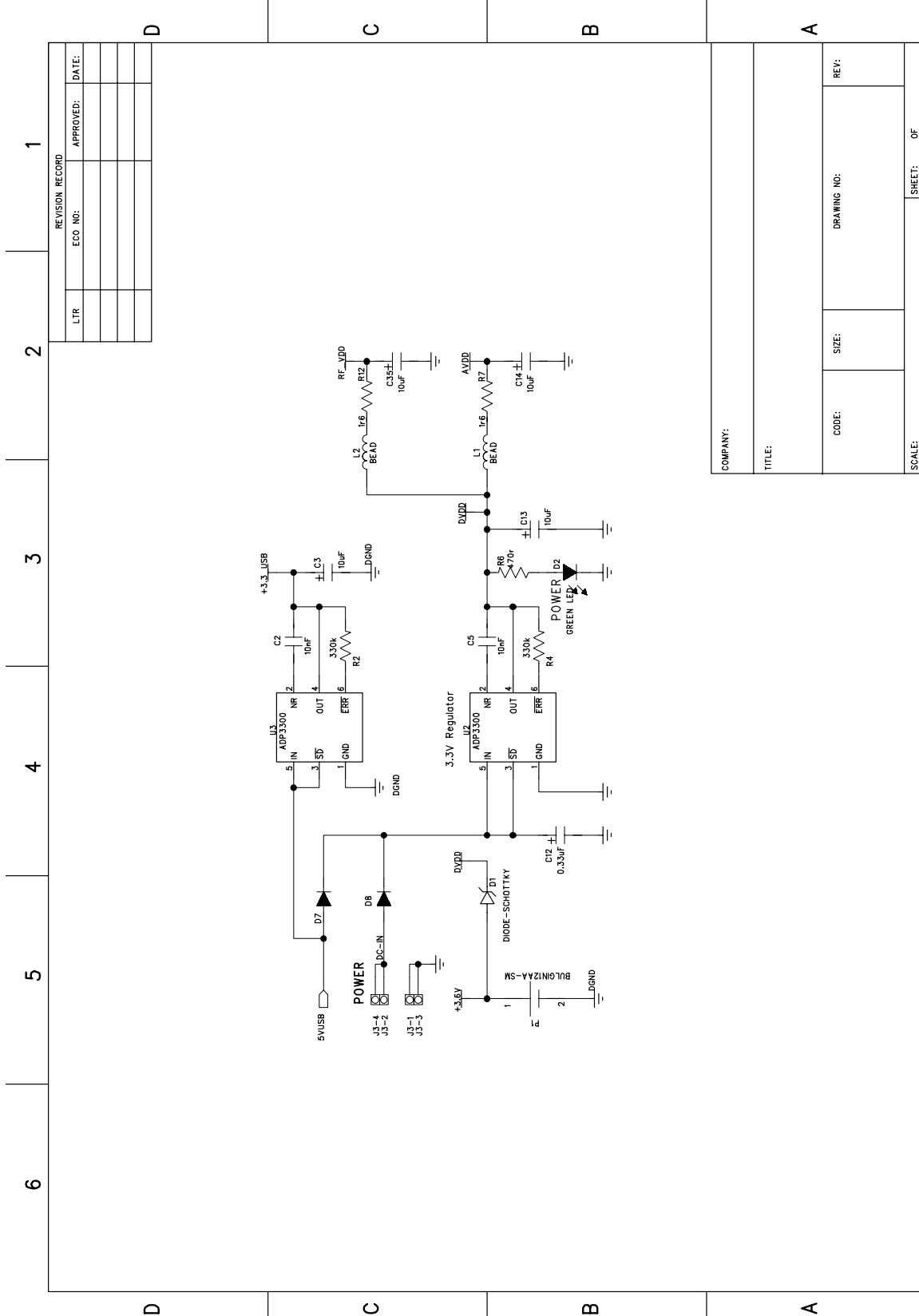

Figure 12. EVAL-ADF70XXMBZ2 Mother Board Schematic – MCU to RF Header section



REVISION RECORD	
LTR	DATE
ECO NO:	APPROVED:

COMPANY:	
TITLE:	
CODE:	DRAWING NO:
SIZE:	REV:
SCALE:	SHEET: OF

Figure 13. EVAL-ADF70XXMBZ2 Mother Board Schematic - Power section

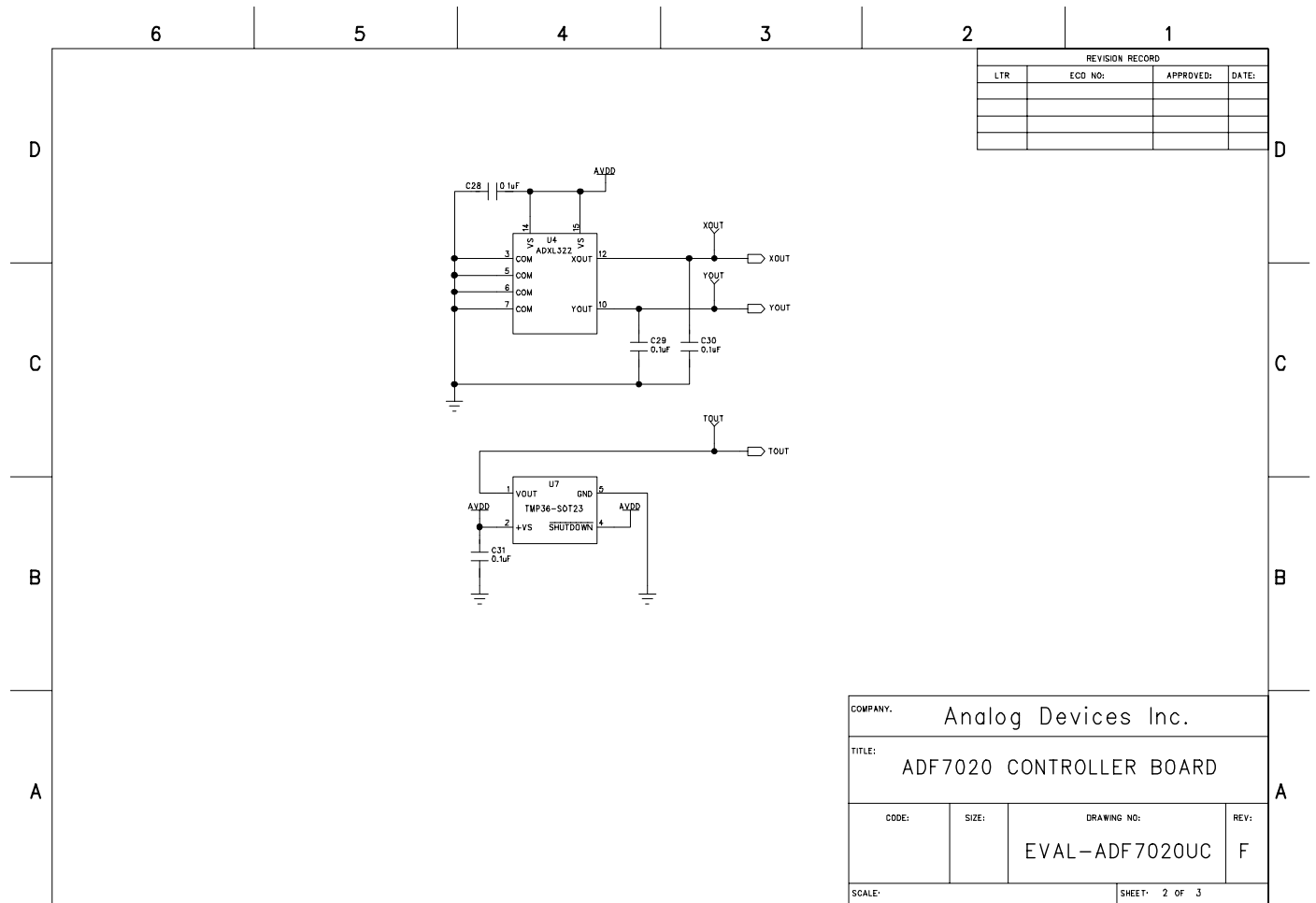

Figure 14. EVAL-ADF70XXMBZ2 Mother Board Schematic - Sensor section

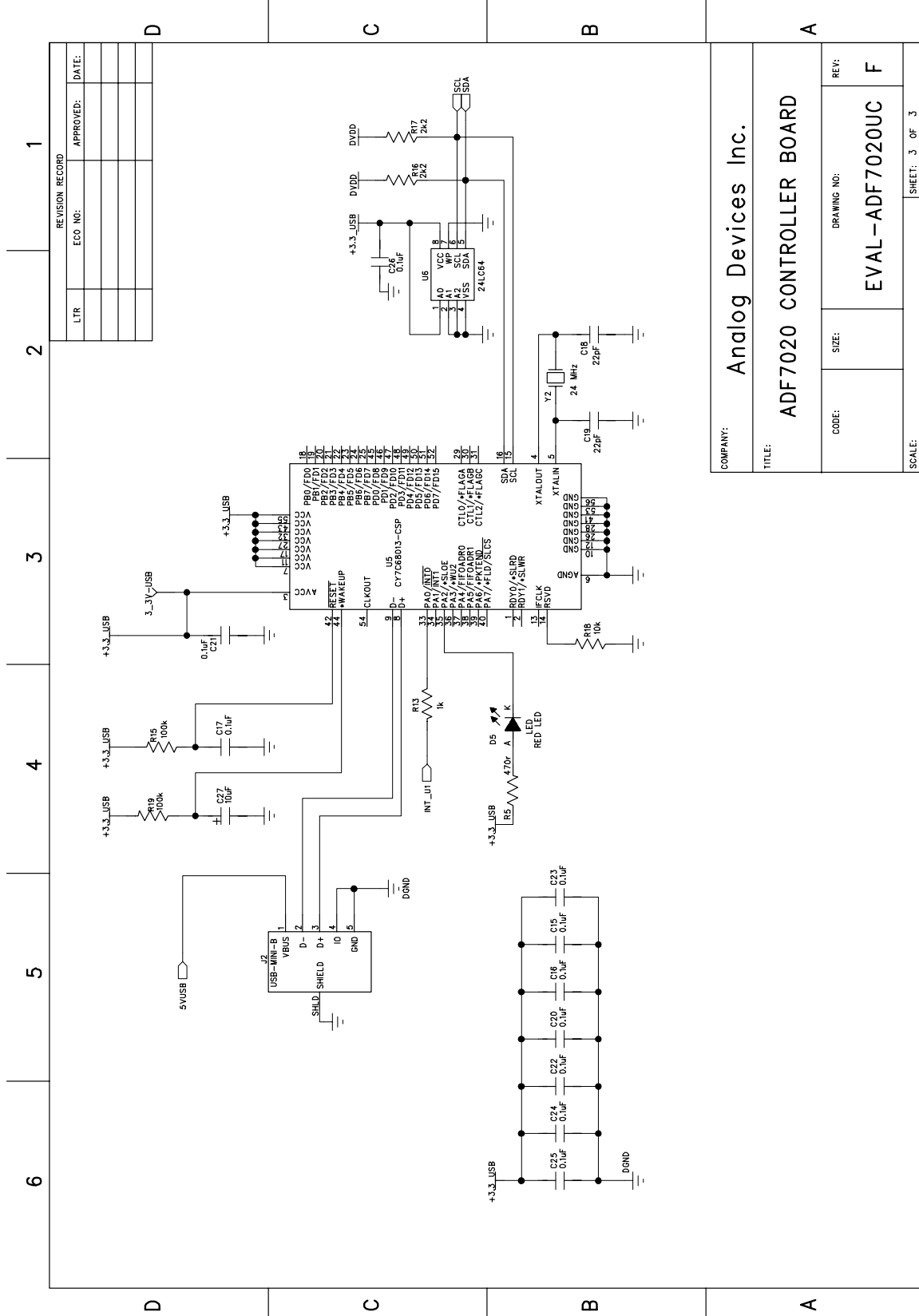

Figure 15. EVAL-ADF70XXMBZ2 Mother Board Schematic - USB section

COMPANY: Analog Devices Inc.			
TITLE: ADF7020 CONTROLLER BOARD			
CODE:	SIZE:	DRAWING NO:	REV: F
EVAL-ADF7020UC			SCALE: 3 OF 3

