

## FEATURES

- All fluids usable in aggressive environment
- Mechanical resistance
- Silicon free

# RS PRO Quick Exhaust Valve 316L FKM F-F 1/8

RS Stock No.: 2312698



RS PROfessionally Approved Products bring to you professional quality parts across all product categories. Our product range has been tested by engineers and provides a comparable quality to the leading brands without paying a premium price.

## Product Description

The RS PRO quick exhaust valve 316L FKM f-f 1/8 works in 0.2 bar to 25 bar pressure range. It is mainly used in chemical, petrochemical, life & sciences, inert gases and vacuum applications. It is also usable in salty environment and on machines that need frequent washing with aggressive detergents. RoHS and REACH compliant.

## General Specifications

<b>Built-In Silencer</b>	1/8
<b>Application</b>	Chemical, Petrochemical, Life & Sciences, Inert Gases And Vacuum Applications

## Mechanical Specifications

<b>Connection Type</b>	1/8 in Female
<b>Threaded Connection Size</b>	Quick Exhaust Valve
<b>Maximum Operating Pressure</b>	25bar
<b>Minimum Operating Pressure</b>	0.2bar

## Similar Products

Parameters	2312700	2312701
Brand	RS PRO	RS PRO
Built-In Silencer	3/8	1/2
Connection Type	3/8 in Female	BSP 1/2 Female
Threaded Connections	Quick Exhaust Valve	Non Return Valve

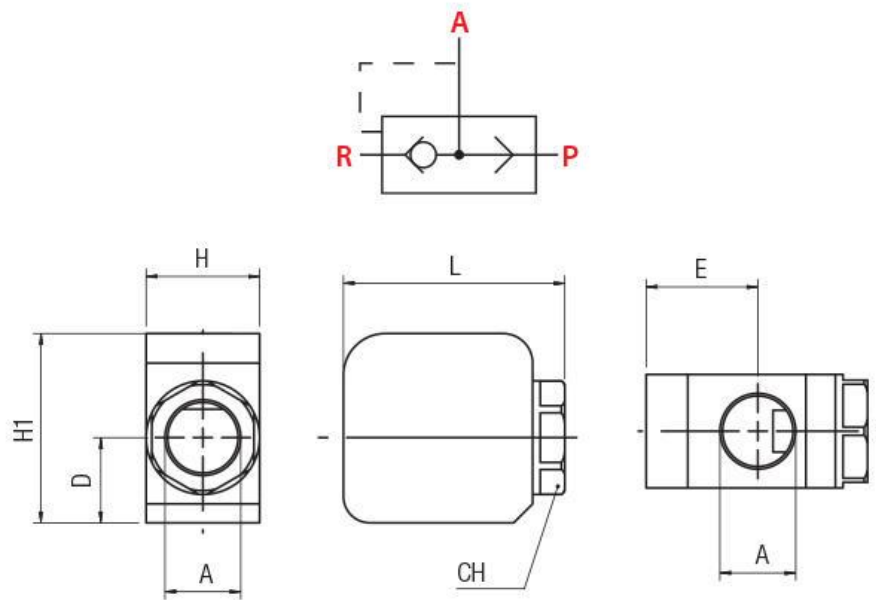

Seals	Thread Size	Ø mm	Viscosity	Kv m3/h	B	C	D
NBR	1/4	10	25	1.88	55.50	72.50	35.20