

Datasheet

## RS Pro Clear Passivated, Zinc Steel Self-Clinching Nut, M4

RS Stock No: **827-625**



### Product Details

RS Pro clinching nut has zinc plated stainless steel construction and is clear passivated for corrosion resistance. This nut is designed for quick installation using a simple press tool. The nut measures 2.4 mm deep with a fixing hole diameter of 5.4 mm. It has M4 threads for a cost-effective means of threaded nut placement in thin sheet metal applications.

### Features and Benefits

- Case hardened mild steel, zinc plated and passivated to BS3382
- Self-dinching nuts should be assembled using a press tool or similar non-shock device
- Hank bushes can be either pressed into place or may be riveted by hand
- Unsuitable for use with sheet materials having a hardness of more than 80Rb



**Specifications:**

Body Depth	2.4 mm
Body Outside Diameter	7.9 mm
Finish	Zinc Plated, Clear Passivated
Fixing Hole Diameter	5.4 mm
Material	Steel
Thickness of Material Maximum	1 mm
Thickness of Material Minimum	0.8 mm
Thread Size	M4

## DIMENSIONAL DATA

### 'PREFERRED' RANGES

The introduction of a range of 'Preferred' products, sizes and material enables designers to specify fasteners which show advantages in stock availability and cost.

'Preferred' sizes are indicated in the tables, by means of a heavy tint. Where design considerations dictate, specific product sizes or materials, are available to order. (See tables). Special variations possible on quotation.

**'Preferred' Material** Case Hardened Mild Steel for use in materials with hardness less than 80 R<sub>B</sub> (150 V<sub>PN</sub>). **(PS type).**

**Other material** — available to order — Stainless Steel BS 970.303 S21.

### (PSS type).

**'Preferred' Finish** Zinc plated and clear passivated to BS 3382.

**Other Finishes** — available to order — Zinc and Chromate (ZC) Zinc and Black Passivate (ZB).

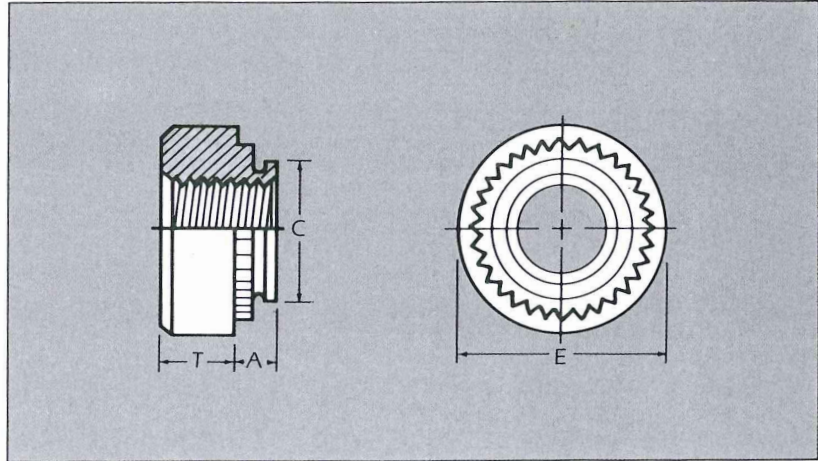

Thread Sizes			Shank No.	For Sheet Thickness	A Maximum	Hole size in sheet +0.075 -0.000	C Maximum	E Approx.	T	Minimum distance centre line hole to sheet edge
BA	UNC	ISO METRIC								
8	2	2	0	0.8-1.0	0.75	4.20	4.15	6.4	1.6	4.8
			1	1.1-1.4	1.05					
			2	1.5-2.3	1.45					
			3	2.4up	2.30					
6	4	2.5	0	0.8-1.0	0.75	4.20	4.15	6.4	1.6	4.8
			1	1.1-1.4	1.05					
			2	1.5-2.3	1.45					
			3	2.4up	2.30					
4	6	3	0	0.8-1.0	0.75	4.75	4.70	7.1	1.6	5.6
			1	1.1-1.4	1.05					
			2	1.5-2.3	1.45					
			3	2.4up	2.30					
—	—	3.5	0	0.8-1.0	0.75	4.75	4.70	7.1	1.6	5.6
			1	1.1-1.4	1.05					
			2	1.5-2.3	1.45					
			3	2.4up	2.30					
—	8	4	0	0.8-1.0	0.75	5.40	5.35	7.9	2.4	6.7
			1	1.1-1.4	1.05					
			2	1.5-2.3	1.45					
			3	2.4up	2.30					
2	10	5	0	0.8-1.0	0.75	6.35	6.30	8.7	2.4	7.0
			1	1.1-1.4	1.05					
			2	1.5-2.3	1.45					
			3	2.4up	2.30					
0	1/4	6	1	1.4-2.3	1.35	8.75	8.70	11.1	4.4	8.7
			2	2.4-3.2	2.30					
			3	3.3up	3.20					
			1	1.4-2.3	1.35					
—	5/16	8	2	2.4-3.2	2.30	10.50	10.45	12.7	6.0	9.5
			3	3.3up	3.20					
			1	2.3-3.2	2.20					
			2	3.3-6.3	3.10					
—	3/8	10	3	6.4up	6.00	12.70	12.65	14.3	6.7	11.0
			1	3.2-6.3	3.10					
			2	6.4up	6.00					
			1	3.2-6.3	3.10					
—	1/2	12	2	6.4up	6.00	16.65	16.60	20.6	9.1	16.0
			1	3.2-6.3	3.10					
			2	6.4up	6.00					
			1	3.2-6.3	3.10					

### HOW TO SPECIFY

When specifying please state:

- 1 Product Name (PS)
- 2 Thread Size
- 3 Shank Number
- 4 Finish if other than 'Preferred'

**Example: PS-M4-2**

- 'PREFERRED' SIZES
- AVAILABLE TO ORDER ONLY
- POSSIBLE ON QUOTATION

	Shank No.	BA					UNIFIED COARSE					ISO METRIC															
		0	2	4	6	8	2	4	6	8	10	1/4	5/16	3/8	1/2	2	2.5	3	3.5	4	5	6	8	10	12		
STEEL	0																										
	1																										
	2																										
	3																										
STAINLESS STEEL	0																										
	1																										
	2																										
	3																										