

# General instruction manual for external gear units



© Bosch Rexroth AG 2020. All rights reserved, also regarding any disposal, exploitation, reproduction, editing, distribution, as well as in the event of applications for industrial property rights.

The data specified within only serves to describe the product. No statements concerning a certain condition or suitability for a certain application can be derived from our information. The information given does not release the user from the obligation of own judgment and verification. It must be remembered that our products are subject to a natural process of wear and aging.

The cover shows an example application. The product delivered may differ from the image on the cover.

The original instruction manual was created in German.

**BG:** Използването на този продукт може да се извърши едва тогава, когато разполагате с това упътване за употреба в разбираема за Вас версия на езика и сте разбрали неговото съдържание. Ако това не е така, обърнете се към Вашия партньор Bosch Rexroth или към компетентен сервиз. Ще го намерите в [www.boschrexroth.com](http://www.boschrexroth.com).

**CS:** Tento výrobek se smí používat jedině tehdy, máte-li k dispozici tento návod k obsluze v pro vás srozumitelné jazykové verzi a rozumíte-li celému jeho obsahu. Pokud tomu tak není, obraťte se na svou kontaktní osobu u firmy Bosch Rexroth nebo na příslušné servisní středisko. To naleznete také na internetové adrese [www.boschrexroth.com](http://www.boschrexroth.com).

**DA:** Dette produkt må ikke anvendes, før du har modtaget og læst driftsvejledningen på et for dig forståeligt sprog og har forstået indholdet. Hvis det ikke er tilfældet, bedes du kontakte din kontaktperson hos Bosch Rexroth eller den ansvarlige kundeserviceafdeling. Den kan du finde på hjemmesiden [www.boschrexroth.com](http://www.boschrexroth.com).

**DE:** Die Verwendung dieses Produkts darf erst dann erfolgen, wenn Sie diese Betriebsanleitung in einer für Sie verständlichen Sprachversion vorliegen und den Inhalt verstanden haben. Ist dies nicht der Fall, wenden Sie sich bitte an Ihren Bosch Rexroth Ansprechpartner oder die zuständige Servicestelle. Diese finden Sie auch unter [www.boschrexroth.com](http://www.boschrexroth.com).

**EL:** Η χρήση αυτού του προϊόντος επιτρέπεται μόνο, εάν διαθέσετε τις παρούσες οδηγίες χρήσης σε κατανοητή γλώσσα και εφόσον έχετε κατανοήσει το περιεχόμενό τους. Εάν δεν πληρούνται αυτές οι προϋποθέσεις, απευθυνθείτε στους κατά τόπους αντιπροσώπους της Bosch Rexroth ή σε κάποιο εξουσιοδοτημένο σέρβις. Για τα σχετικά στοιχεία επισκεφτείτε την ιστοσελίδα [www.boschrexroth.com](http://www.boschrexroth.com).

**EN:** This product may only be used if these operating instructions are available to you in a language version that you can understand and if you have understood its content. If this is not the case, please contact your Bosch Rexroth contact partner or the responsible service point. You can also find them under [www.boschrexroth.com](http://www.boschrexroth.com).

**ES:** Este producto únicamente podrá utilizarse cuando disponga de las instrucciones de servicio en un idioma que entienda y haya entendido su contenido. En caso contrario, diríjase a su persona de contacto de Bosch Rexroth o al servicio técnico competente, que podrá encontrar también en la dirección [www.boschrexroth.com](http://www.boschrexroth.com).

**ET:** Toodeid tohib kasutada ainult siis, kui teil on olemas teie jaoks arusaadavas keeles kasutusjuhend ja te saate selle sisust aru. Kui see nii ei ole, pöörduge oma Bosch Rexrothi esindaja või vastava teeninduse poole. Nende kontaktandmed leiate aadressilt [www.boschrexroth.com](http://www.boschrexroth.com).

**FI:** Älä käytä tuotetta ennen kuin olet saanut käyttöohjeen omalla kielelläsi ja ymmärrät sen sisällön. Ota muussa tapauksessa yhteyttä Bosch Rexroth -yhteyshenkilösi tai valtuutettuun huoltoliikkeeseen. Yhteystiedot löydät osoitteesta [www.boschrexroth.com](http://www.boschrexroth.com).

**FR:** Ce produit ne doit être utilisé que lorsque vous disposez des présentes instructions de service en une version linguistique que vous comprenez et que vous avez compris son contenu. Si cela n'est pas le cas, veuillez vous adresser à votre interlocuteur Bosch Rexroth ou au service compétent. Vous trouvez les coordonnées également sur le site [www.boschrexroth.com](http://www.boschrexroth.com).

**HU:** A terméket csak akkor szabad használni, ha ez a kezelési útmutató rendelkezésre áll az Ön számára érthető egyik nyelven, és megértette annak tartalmát. Egyéb esetben forduljon a Bosch Rexroth kapcsolattartójához vagy az illetékes szervizhez. Ezeket is megtalálja az alábbi címen: [www.boschrexroth.com](http://www.boschrexroth.com).

**IT:** Questo prodotto può essere impiegato solo se si dispone del presente manuale d'uso in una lingua conosciuta e se ne è stato compreso il contenuto. In caso contrario rivolgersi al referente Bosch Rexroth o al punto di assistenza competente. Questi sono anche riportati sul sito [www.boschrexroth.com](http://www.boschrexroth.com).

**LT:** Naudoti šį produktą leidžiama tik turint šią vartotojo instrukciją Jums suprantama kalba ir jei supratote jos turinį. Jei instrukcijos nesuprantate, prašome kreiptis į savo Bosch Rexroth konsultantą arba atsakingą aptarnavimo tarnybą. Informaciją apie juos rasite adresu [www.boschrexroth.com](http://www.boschrexroth.com).

**LV:** Šo ierīci drīkst lietot tikai tad, ja šī ekspluatācijas instrukcija Jums ir pieejama kādā jums saprotamā valodā un Jūs esat izpratis tās saturu. Pretējā gadījumā lūdzam vērsties pie attiecīgās „Bosch Rexroth“ kontaktpersonas vai kompetentā servisa dienestā. Nepieciešamā informācija ir pieejama arī mūsu mājas lapā internetā [www.boschrexroth.com](http://www.boschrexroth.com).

**NL:** U mag het product pas gebruiken, als deze bedieningshandleiding voor u beschikbaar is in een voor u begrijpelijke taal en als u de inhoud daarvan begrepen heeft. Is dit niet het geval, neem dan a.u.b. contact op met uw Bosch Rexroth contactpersoon of de servicepartner. Deze vindt u ook op [www.boschrexroth.com](http://www.boschrexroth.com).

**NO:** Dette produktet må ikke brukes før du har mottatt denne bruksanvisningen på et språk som du forstår, og du har forstått innholdet. Hvis dette ikke er tilfellet, ta kontakt med din kontaktperson hos Bosch Rexroth eller den ansvarlige kundeserviceavdelingen. Disse finner du også på [www.boschrexroth.com](http://www.boschrexroth.com).

**PL:** Przed przystąpieniem do eksploatacji niniejszego produktu należy zapoznać się z instrukcją obsługi w Państwa wersji językowej. W przypadku, gdy nie dołączono instrukcji w danym języku, należy zwrócić się z zapytaniem do osoby kontaktowej Bosch Rexroth lub do odpowiedniego punktu obsługi. Listę takich punktów można znaleźć na stronie [www.boschrexroth.com](http://www.boschrexroth.com).

**PT:** Este produto só pode ser utilizado se o manual de instruções estiver disponível em um idioma compreensível para você e se você tiver compreendido o conteúdo do mesmo. Se esse não for o caso, entre em contato com o seu representante da Bosch Rexroth ou com a assistência técnica. Encontre-os em [www.boschrexroth.com](http://www.boschrexroth.com)

**RO:** Aveți voie să utilizați acest produs, doar după ce ați primit acest manual de utilizare într-o versiune de limbă inteligibilă pentru dumneavoastră și ați înțeles conținutul său. Dacă aceste condiții nu sunt îndeplinite, adresați-vă persoanei dumneavoastră de contact de la Bosch Rexroth sau la service-ul Bosch Rexroth competent. Găsiți aceste service-uri la [www.boschrexroth.com](http://www.boschrexroth.com)

**RU:** Использование данного продукта разрешается только после получения Вами настоящего руководства по эксплуатации на русском языке и его внимательного изучения. Если у Вас нет руководства по эксплуатации, обратитесь, пожалуйста, к ответственному за Ваш регион представителю Bosch Rexroth или в соответствующий сервисный центр. Оно также находится на сайте [www.boschrexroth.com](http://www.boschrexroth.com).

**SK:** Tento výrobok sa smie používať až vtedy, keď ste dostali tento návod na prevádzku k dispozícii v pre vás zrozumiteľnej jazykovej mutácii a obsahu ste porozumeli. V opačnom prípade sa, prosím, obráťte na vašu kontaktnú osobu v Bosch Rexroth alebo na zodpovedné servisné miesto. Nájdete ich tiež na [www.boschrexroth.com](http://www.boschrexroth.com).

**SL:** Z uporabo tega izdelka lahko pričnete šele, ko ste prebrali ta navodila za uporabo v vam razumljivem jeziku in razumeli njihovo vsebino. Če navodila za uporabo niso na voljo v vašem jeziku, vas prosimo, da se obrnete na kontaktno osebo podjetja Bosch Rexroth oz. pooblaščenim servis. Te lahko najdete tudi na [www.boschrexroth.com](http://www.boschrexroth.com).

**SV:** Denna produkt får inte användas förrän du har mottagit en bruksanvisning på ett språk som du förstår och sedan har läst och förstått innehållet i. Om detta inte är fallet ber vi dig kontakta din kontaktperson på Bosch Rexroth eller ansvarig kundservice. Dessa hittar du också på [www.boschrexroth.com](http://www.boschrexroth.com).

**ZH:** 使用该产品前, 请您确保已拥有一份您所熟悉语言版本的使用说明书并已理解其内容。如果尚未拥有, 请向博世力士乐合作伙伴或相关服务部门索取, 也可登录 [www.boschrexroth.com](http://www.boschrexroth.com) 下载。

# Contents

<b>1</b>	<b>About this documentation .....</b>	<b>7</b>
1.1	Validity of the documentation .....	7
1.2	Required and supplementary documentation.....	7
1.3	Representation of information.....	8
1.3.1	Safety instructions .....	8
1.3.2	Symbols .....	9
1.3.3	Designations .....	9
1.3.4	Abbreviations .....	10
<b>2</b>	<b>Safety instructions .....</b>	<b>11</b>
2.1	About this chapter.....	11
2.2	Intended use .....	11
2.3	Improper use.....	11
2.4	Personnel qualifications .....	12
2.5	General safety instructions .....	13
2.6	Product-specific safety instructions .....	14
2.7	Personal protective equipment.....	16
<b>3</b>	<b>General instructions on property damage and product damage.....</b>	<b>17</b>
<b>4</b>	<b>Scope of delivery.....</b>	<b>20</b>
<b>5</b>	<b>About this product .....</b>	<b>21</b>
5.1	Performance description .....	21
5.2	Product description .....	21
5.2.1	Layout of the external gear unit.....	21
5.2.2	Functional description .....	22
5.3	Product identification.....	23
5.4	Information on use at low temperatures.....	23
5.5	Project planning notes .....	24
<b>6</b>	<b>Transport and storage .....</b>	<b>28</b>
6.1	Transporting the external gear unit .....	28
6.1.1	Transport by hand.....	28
6.1.2	Transport with lifting devices .....	29
6.2	Storing the external gear units .....	29
<b>7</b>	<b>Installation.....</b>	<b>32</b>
7.1	Unpacking .....	32
7.2	Installation conditions.....	33
7.3	Installation position .....	33
7.4	Installing the external gear units.....	34
7.4.1	Preparation .....	34
7.4.2	Dimensions .....	35
7.4.3	General instructions.....	35
7.4.4	Installation with a coupling.....	36
7.4.5	Completing installation .....	38
7.4.6	Hydraulically connecting the external gear unit.....	39
7.4.7	Performing flushing cycle .....	43
<b>8</b>	<b>Commissioning.....</b>	<b>44</b>
8.1	Initial commissioning .....	45
8.1.1	Filling the external gear unit .....	46
8.1.2	Testing the hydraulic fluid supply.....	47
8.1.3	Performing a functional test.....	47
8.2	Running-in phase .....	48
8.3	Recommissioning after standstill .....	48

<b>9</b>	<b>Operation .....</b>	<b>49</b>
<b>10</b>	<b>Maintenance and repair .....</b>	<b>50</b>
10.1	Cleaning and care .....	50
10.2	Inspection .....	50
10.3	Maintenance .....	51
10.4	Repair .....	51
10.5	Spare parts .....	51
<b>11</b>	<b>Removal and replacement .....</b>	<b>53</b>
11.1	Required tools .....	53
11.2	Preparing for removal .....	53
11.3	Performing the removal .....	53
11.4	Preparing the components for storage or further use .....	53
<b>12</b>	<b>Disposal .....</b>	<b>54</b>
<b>13</b>	<b>Extension and conversion .....</b>	<b>54</b>
<b>14</b>	<b>Troubleshooting .....</b>	<b>55</b>
14.1	How to proceed for troubleshooting .....	55
14.2	Malfunction table .....	56
<b>15</b>	<b>Technical data .....</b>	<b>59</b>
<b>16</b>	<b>Alphabetical index .....</b>	<b>60</b>

# 1 About this documentation

## 1.1 Validity of the documentation

This documentation is valid for the following products:

External gear units from Bosch Rexroth, which include:

- External gear pumps
- External gear motors

This documentation is intended for machine/system manufacturers, assemblers and service engineers.



This documentation contains important information on the safe and proper transport, installation, commissioning, operation, maintenance, disassembly and simple troubleshooting of the external gear unit.

- ▶ Read this documentation completely and in particular chapter 2 "Safety instructions" on page 11 and chapter 3 "General instructions on property damage and product damage" on page 17 before you start work with the external gear unit.





## 1.2 Required and supplementary documentation

- ▶ Only commission the external gear unit if the documentation marked with the book symbol  is available to you and you have understood and observed it.

**Table 1: Required and supplementary documentation**

Title	Document number	Document type
 <b>Order confirmation</b> Contains the order-based technical data of your external gear units AZP and AZM.	–	Order confirmation
 <b>Offer drawing</b> Contains the pre-set technical data. The external gear unit may only be operated under the values and conditions specified in the offer drawing.	Please request the offer drawing from your contact at Bosch Rexroth.	Offer drawing
 <b>Technical data sheet</b> Contains, among other things, the permissible technical data for the external gear unit. Also observe the information contained in the offer drawing. Please bear in mind that different technical data sheets apply depending on the external gear unit:		Data sheet
External gear pump Standard AZPW	10090	
External gear pump High Performance AZPB	10088	
External gear pump High Performance AZPF	10089	
External gear pump High Performance AZPN	10091	
External gear pump High Performance AZPG	10093	
External gear pump SILENCE AZPS	10095	
External gear pump SILENCE AZPT	10092	
External gear pump SILENCE AZPU	10098	
External gear pump SILENCE PLUS ASPJ	10094	
External gear motor High Performance AZMB	14027	
External gear motor High Performance AZMF	14028	
External gear motor High Performance AZMN	14029	
External gear motor High Performance AZMG	14030	

**Table 1: Required and supplementary documentation**

Title	Document number	Document type
 <b>Hydraulic fluids based on mineral oils and related hydrocarbons</b> Describes the requirements for hydraulic fluids on mineral oil basis and related hydrocarbons for operation with Rexroth hydraulic components and provides support for selection of suitable hydraulic fluids for the hydraulic system.	90220	Data sheet
 <b>Environmentally acceptable hydraulic fluids</b> Describes the requirements on an environmentally acceptable hydraulic fluid for operation with Rexroth hydraulic components and assists you in selecting a hydraulic fluid for your hydraulic system.	90221	Data sheet
 <b>Fire-resistant, water-free hydraulic fluids (HFDR/HFDU)</b> Describes the requirements on fire-resistant, water-free hydraulic fluids (HFDR/HFDU) for operation with Rexroth hydraulic components and assists you in selecting a hydraulic fluid for your hydraulic system.	90222	Data sheet
 <b>Fire-resistant hydraulic fluids – containing water (HFAE, HFAS, HFB, HFC)</b> Describes the requirements on fire-resistant, water-containing hydraulic fluids (HFAE, HFAS, HFB, HFC) for operation with Rexroth hydraulic components and assists you in selecting a hydraulic fluid for your hydraulic system.	90223	Data sheet
 <b>Y sheet</b> Please bear in mind that different technical data sheets apply depending on the external gear unit:		Data sheet
AZPB	Y 510 100 172	
AZPF	Y 510 201 598	
AZPS	Y 510 201 777	
AZPJ	Y 518 400 019	
AZPN/AZPT	Y 510 300 033	
AZPG/AZPU	Y 510 400 419	
AZPW (NBR seal)	Y 510 202 148	
AZPW (FPM seal)	Y 510 202 154	
AZMB	Y 511 100 032	
AZMF	Y 511 200 028	
AZMN	Y 511 300 001	
Information tightening torque	Y 510 202 040	

### 1.3 Representation of information

Uniform safety instructions, symbols, terms and abbreviations are used throughout this documentation to ensure safe and proper use of the product. For clarification, they are explained in the sections below.

#### 1.3.1 Safety instructions

This documentation contains safety instructions in chapter 2.6 "Product-specific safety instructions" on page 14 and in chapter 3 "General instructions on property damage and product damage" on page 17, as well as before a sequence of actions or an instruction for action involving a risk of personal injury and property damage. Always follow the measures for danger prevention associated with the use of this product.

The safety guidelines in this manual are for the external gear unit only. Please also take into account the safety guidelines from the machine/system manufacturer.





Safety instructions are set out as follows:

 <b>SIGNAL WORD</b>
<p><b>Type and source of danger</b></p> <p>Consequences of noncompliance</p> <p>▶ Danger prevention measures</p>

- **Warning sign:** draws attention to the danger
- **Signal word:** identifies the degree of the danger
- **Type and source of danger:** indicates the type and source of the danger
- **Consequences:** describes what occurs if safety instructions are disregarded
- **Precautions:** states how the danger can be avoided

**Table 2: Hazard classes as defined in ANSI Z535.6**

Warning sign, signal word	Meaning
 <b>DANGER</b>	Identifies a dangerous situation that will result in death or serious injury if it is not avoided.
 <b>WARNING</b>	Identifies a dangerous situation that may result in death or serious injury if it is not avoided.
 <b>CAUTION</b>	Identifies a dangerous situation that may result in minor to moderate injury if it is not avoided.
<b>NOTICE</b>	Property damage: The product or surrounding area may be damaged.

### 1.3.2 Symbols

The following symbols indicate notices that are not safety-relevant but increase understanding of the documentation.

**Table 3: Meaning of symbols**

Symbol	Meaning
	If this information is disregarded, the product cannot be used and/or operated to its full extent.
▶	Single, independent action
1.	Numbered instruction:
2.	The numbers indicate that the actions must be completed in order.
3.	

### 1.3.3 Designations

This documentation uses the following designations:

**Table 4: Designations**

Designation	Meaning
AZ	External gear unit
AZP	External gear pump
AZM	External gear motor
Threaded plug	Metal screw, pressure-resistant
Protective plug	Made out of plastic, not pressure-resistant, only for transportation

### 1.3.4 Abbreviations

This documentation uses the following abbreviations:

**Table 5: Abbreviations**

<b>Abbreviation</b>	<b>Meaning</b>
ANSI	American National Standards Institute is an organization that coordinates the development of voluntary standards in the United States
ATEX	EC directive on explosion protection ( <b>A</b> tmosphère <b>ex</b> plosible)
DIN	<b>D</b> eutsche <b>I</b> ndustrie <b>N</b> orm (German Institute for Standardization)
ISO	<b>I</b> nternational <b>O</b> rganization for <b>S</b> tandardization
JIS	<b>J</b> apan <b>I</b> ndustrial <b>S</b> tandard
RE	<b>R</b> exroth document in the <b>E</b> nglish language
VDI 2230	Directive for the systematic calculation of high duty bolted joints and joints with one cylindrical bolt from the VDI ( <b>V</b> erein <b>D</b> eutscher <b>I</b> ngenieure - Association of German Engineers)

## 2 Safety instructions

### 2.1 About this chapter

The external gear units have been manufactured according to the generally accepted rules of current technology. There is still, however, a risk of personal injury or property damage if this chapter and the safety instructions in this documentation are not observed.

- ▶ Read this documentation completely and thoroughly before working with the external gear unit.
- ▶ Keep the documentation in a location where it is accessible to all users at all times.
- ▶ Always include the required documentation when you pass the external gear unit on to third parties.

### 2.2 Intended use

External gear units are hydraulic components, meaning that in their field of application they are classified neither as complete nor as partially completed machinery in the sense of the EC Machinery Directive 2006/42/EC. The component is exclusively intended to form partly completed machinery or complete machinery together with other components. The component should only be commissioned after it has been installed in the machine/system for which it is intended, and the safety of the entire system has been established in accordance with the Machinery Directive. This product is intended for the following use:

The external gear unit is only allowed to be used as a hydraulic pump or hydraulic motor as part of the layout of hydraulically driven systems in machinery and system engineering.

It is not approved in on-highway vehicles for safety-relevant functions, as well as functions in the drive train, for steering, braking and level regulation.

- ▶ Adhere to the technical data, the application and operating conditions and the performance limits as specified in the data sheet (see Table 1, Page 7) and in the order confirmation. More information on permissible hydraulic fluids can be found in data sheets 90220, 90221, 90222 and 90223.

The external gear unit is only intended for professional use and not private use. Intended use includes having read and understood the complete documentation, especially chapter 2 "Safety instructions" on page 11.

### 2.3 Improper use

Any use other than that described as intended use is considered improper.

Bosch Rexroth AG is not liable for damages resulting from improper use. The user is solely responsible for any risks arising from improper use.

The following foreseeable forms of faulty usage are also considered improper (this list is not exhaustive):

- Use outside the operating parameters approved in the data sheet and in the order confirmation (unless specifically approved by the customer)
- Use of non-approved fluids, e.g. water or polyurethane components
- Changes to factory settings by unauthorized persons.
- Use of assembled parts (e.g. attachment filter, control unit, valves) other than specified Rexroth components

- Use of the external gear unit under water without necessary additional measures, e.g. pressure equalization
- Use of the external gear unit without necessary additional measures if the ambient pressure is higher than 2 bar absolute
- Use of the external gear unit when the ambient pressure is greater than the interior pressure
- Use of the external gear unit in explosive environments unless the component or machine/system has been certified as compliant with the ATEX directive 94/9/EC
- Using the external gear unit in a corrosive atmosphere
- Use of the external gear unit in aircraft or spacecraft
- Use in on-highway vehicles for safety-relevant functions, in the drive train, for steering, braking and level regulation. Self-propelled working machines are not classified as on-highway vehicles.

## 2.4 Personnel qualifications

The activities described in this documentation require a basic understanding of mechanics, electricity and hydraulics, as well as familiarity with associated technical terms. For transporting and handling the product, knowledge regarding the use of lifting devices and lifting accessories is required. In order to ensure safe use, these activities should only be performed by skilled personnel or an instructed person under the direction and supervision of skilled personnel.

Skilled personnel refers to persons who possess the professional training, knowledge and experience, as well as the understanding of the regulations relevant to the work to be done that are necessary to recognize possible dangers and take the appropriate safety measures. Skilled personnel must follow the rules relevant to their field and have the necessary hydraulic expert knowledge.

Hydraulic expert knowledge includes:

- Being able to read and fully understand hydraulic circuit diagrams
- In particular, fully understanding the relationships with regard to safety devices
- Knowledge regarding the function and interaction of hydraulic components.



Bosch Rexroth offers you measures supporting training in specific areas. You can find an overview of the training contents on the Internet at:

[www.boschrexroth.com/training](http://www.boschrexroth.com/training).

## **2.5 General safety instructions**

- Observe applicable accident prevention and environmental protection regulations.
- Observe the safety regulations of the country in which the product is used/operated.
- Use Rexroth products only when they are in good working order.
- Observe all notices on the product.
- Persons who install, operate, disassemble or maintain Rexroth products may not be under the influence of alcohol, drugs or medication that may affect their reaction time.
- Only use genuine Rexroth accessories and spare parts to ensure there is no hazard to persons from unsuitable spare parts.
- Observe the technical data and ambient conditions specified in the product documentation.
- If unsuitable products are installed or used in applications that are of relevance to safety, unexpected operating conditions may occur in the application, which could result in personal injury or property damage. For this reason, only use the product in a safety-related application if this use is expressly specified and permitted in the product documentation, for example in explosion protection areas or in safety-related parts of a control system (functional safety).
- Only commission the product if it has been determined that the end product (e.g. machinery or system) in which the Rexroth products are installed complies with the country-specific provisions, safety regulations and standards for the application.
- Use tools appropriate for the work being performed and wear appropriate protective clothing to prevent punctures and cuts (e.g. when removing protective covers, disassembly).
- There is a risk of entanglement when operating the external gear unit with a bare shaft end. Check whether or not your machine requires additional safety measures for your application. If necessary, make sure these are appropriately implemented.
- Depending on the type of control used, electromagnetic effects can be produced when using solenoids. Applying a direct voltage signal (DC) to solenoids does not create electromagnetic interference (EMI) nor is the solenoid affected by EMI. Potential electromagnetic interference (EMI) exists if the solenoid is energized with a modulated direct current (e.g. PWM signal). The machine manufacturer should conduct appropriate tests and take appropriate measures to ensure that other components or operators (e.g. with a pacemaker) are not affected by this potentiality.

## 2.6 Product-specific safety instructions

The following safety instructions apply to chapters 6 to 14.

### **WARNING**

#### **Danger from excessive pressure!**

Risk of death or injury, or property damage!

Improperly changing the factory pressure settings can result in a pressure increase beyond the maximum permissible pressure.

Operating the unit above the maximum permissible pressure can cause components to burst and hydraulic fluid to escape under high pressure.

- ▶ Changes to the factory settings may only be made by Bosch Rexroth specialists.
- ▶ In addition, a pressure relief valve is required in the hydraulic system as a back-up. If the external gear unit is equipped with a pressure cut-off and/or a pressure controller, this is not an adequate back-up against pressure overload.

#### **Danger due to suspended loads!**

Risk of death or injury, or property damage!

Improper transportation may cause the external gear unit to fall down and lead to injuries e.g. crushing or broken bones or damage to the product.

- ▶ Make sure that the fork lift truck or lifting device has adequate lifting capacity.
- ▶ Never stand or reach under suspended loads.
- ▶ Ensure a stable transport position.
- ▶ Use your personal protective equipment (e.g. safety goggles, safety gloves, suitable working clothes, safety shoes).
- ▶ Use suitable lifting devices for transport.
- ▶ Observe the prescribed position of the lifting strap.
- ▶ Observe the national laws and regulations on occupational health and safety, and transportation.

#### **System/machine under pressure!**

Risk of death or serious injury when working on unsecured machines/systems!

Property damage!

- ▶ Switch off the relevant machine/system part and secure it against reactivation according to the parameters by the machine/system manufacturer.
- ▶ Ensure that all relevant components of the hydraulic system are depressurized. For this purpose, observe the parameters indicated by the machine/system manufacturer.
- ▶ Please note that the hydraulic system might still be pressurized even after separation from the actual pressure supply.
- ▶ Do not disconnect any line connections, ports or components as long as the hydraulic system is under pressure.
- ▶ Switch off all power-transmitting components and connections (electric, pneumatic, hydraulic, mechanical) in line with the manufacturer's specifications and secure them against being turned back on.

 **WARNING****Escaping hydraulic fluid mist!**

Risk of explosion and fire hazard, health hazard, risk of environmental pollution!

- ▶ Depressurize the machine/system and repair the leak.
- ▶ Only perform welding work when the machine/system is depressurized.
- ▶ Keep open flames and ignition sources away from the external gear unit.
- ▶ If external gear units are located in the vicinity of ignition sources or powerful thermal radiators, a shield must be erected to ensure that any escaped hydraulic fluid cannot be ignited, and to protect hose lines from premature aging.

**Escaping hydraulic fluid due to leakage of machine/system components!**

Risk of burning and risk of injury due to escaping hydraulic fluid jet! In case of leakage at the external gear unit, high-pressure fluid jets may escape.

- ▶ Depressurize the relevant machine/system component and repair the leak.
- ▶ Never attempt to block or seal the leak or hydraulic fluid jet with a cloth.

**Hydraulic fluid will explode when making contact with water.**

Risk of explosion and fire!

- ▶ Do not bring hot hydraulic fluids in contact with water.

**Electrical voltage!**

Danger to life or risk of injury due to electric shock or property damage!

- ▶ Always disconnect the voltage supply to the relevant machine/system part before installing the product and/or connecting or disconnecting the connector. Protect the machine/system against being re-energized.

## CAUTION

### **High noise development during operation!**

Risk of hearing damage or hearing loss!

The noise emission of external gear units depends on, among other factors, rotational speed, working pressure, and installation conditions. The sound pressure level may rise above 70 dB (A) under normal application conditions.

- ▶ Always wear hearing protection when in the vicinity of the operating external gear unit.

### **Danger due to noise effects!**

In unauthorized operating conditions (e.g. overspeed, lack of supply) and faulty components (e.g. outboard bearings) unexpected noises and noise effects may arise.

- ▶ If there is an increase in unusual noise, have Service identify and resolve the faults.

### **Hot surfaces on the external gear unit!**

Risk of burning!

- ▶ Allow the external gear unit to cool down before touching it.
- ▶ Wear heat-resistant, protective clothing, e.g. gloves.

### **Improper cable and line routing!**

Risk of stumbling and property damage! Improper routing of lines and cables can cause a risk of stumbling as well as damage to parts and components, e.g. by tearing off lines and connectors.

- ▶ Always lay cables and lines so no one can trip over them, they do not become kinked or twisted, do not rub on edges and do not run through sharp-edged ducts without adequate protection.

### **Contact with hydraulic fluid!**

Risk of adverse health effects, e.g. eye injury, skin irritation, toxication from inhalation!

- ▶ Avoid any contact with hydraulic fluids.
- ▶ When handling hydraulic fluids, the safety instructions of the lubricant manufacturer need to be observed at all times.
- ▶ Use your personal protective equipment (e.g. safety goggles, safety gloves, suitable working clothes, safety shoes).
- ▶ Immediately seek medical attention, however, if hydraulic fluid gets into your eyes or blood circuit or if you swallow it accidentally.

### **Danger from improper handling!**

Slip hazard! When using the external gear unit as a climbing aid there is a risk of slipping on wet surfaces when climbing on the external gear unit.

- ▶ Never grab or climb onto the external gear unit.
- ▶ Check how to safely get on top of the machine/system.

## **2.7 Personal protective equipment**

Personal protective equipment is the responsibility of the user of the external gear unit. Observe the safety regulations in your country.

All pieces of personal protective equipment should be intact.



### 3 General instructions on property damage and product damage

The following instructions apply to chapters 6 to 14.

#### **NOTICE**

##### **Danger from improper handling!**

Product can be damaged!

- ▶ Do not subject the product to improper mechanical loads.
- ▶ Never use the product as handle or step.
- ▶ Do not place/lay any objects on the product.
- ▶ Do not strike the drive shaft of the external gear unit.
- ▶ Do not set/place the external gear unit on the drive shaft or assembled parts.
- ▶ Do not strike assembled parts (e.g. sensors or valves).
- ▶ Do not strike sealing surfaces (e.g. working ports).
- ▶ Leave the protective covers on the external gear unit until you connect the lines.
- ▶ Disconnect all electrical connectors before arc welding or painting.
- ▶ Make sure the electronic components (e.g. sensors) do not build up electrostatic charges (e.g. during painting).

##### **Risk of property damage due to inadequate lubrication!**

Product can be damaged or destroyed!

- ▶ Never operate the external gear unit with insufficient hydraulic fluid. Specifically, make sure that the rotary group has sufficient lubrication.
- ▶ When commissioning a machine/system, make sure that the housing area and the working lines of the external gear unit are filled with hydraulic fluid and remain filled during operation. Avoid air inclusions in the forward drive shaft bearing, especially with the axial piston unit installed with the drive shaft up.
- ▶ When commissioning a machine/system, make sure that the valves, cylinders and actuators and their working lines are filled with hydraulic fluid and remain filled during operation. Otherwise, the machinery/system may respond unexpectedly.
- ▶ Check the hydraulic fluid level in the housing area regularly and recommission, if necessary. For above-reservoir installation, the housing area may drain out through the drain line after prolonged standstill periods (air enters through the shaft seal) or through the working line (gap leakage). This means the bearings are insufficiently lubricated when the system is turned on.
- ▶ Make sure the suction line is always filled with hydraulic fluid during commissioning and operation.

Especially, when doing an above-reservoir installation the external gear unit must be able to draw in hydraulic fluid (air bleeding of the suction line necessary).

## NOTICE

### **Mixing hydraulic fluids!**

Product can be damaged!

- ▶ Before installation, remove all fluids from the external gear unit to prevent mixing with the hydraulic fluid used in the machine/system.
- ▶ Any mixture of hydraulic fluids of different manufacturers and/or different types of the same manufacturer is generally not permissible.

### **Contamination of hydraulic fluid!**

The cleanliness of the hydraulic fluid impacts the service life of the external gear unit. Contamination of the hydraulic fluid may lead to premature wear and malfunctions!

- ▶ Always ensure a work environment in the assembly location that is free from dust and foreign particles to prevent foreign particles, e.g. welding beads or metal cuttings, from entering the hydraulic lines and lead to wear and malfunctions in the product. The external gear unit must be installed in clean condition.
- ▶ Use only clean ports, hydraulic lines and assembled parts (e.g. measuring devices).
- ▶ When plugging the ports, no contamination may ingress.
- ▶ Before commissioning, ensure that all hydraulic connections are tight and that all seals and plugs of the plug-in connection are correctly installed and undamaged to prevent fluids and foreign particles from entering the product.
- ▶ Filter the hydraulic fluid when filling the system with a suitable filter system to minimize the solid particle contamination and water in the hydraulic system and to achieve the required cleanliness level.

### **Improper cleaning!**

Product can be damaged!

- ▶ Plug all openings with appropriate protective covers in order to prevent cleaning agents from entering the external gear unit.
- ▶ Never use solvents or aggressive cleaning agents.
- ▶ Use only water and, if necessary, a mild cleaning agent to clean the external gear unit.
- ▶ Do not point a high-pressure cleaner at sensitive components, e.g. shaft seal, electrical connections and components.
- ▶ Use fiber-free cloths for cleaning.

### **Environmental pollution due to improper disposal!**

Careless disposal of the external gear unit and its assembled parts, the hydraulic fluid and the packaging material can result in environmental pollution.

- ▶ Dispose of the external gear unit, hydraulic fluid and packaging in accordance with the national regulations in your country.
- ▶ Dispose of the hydraulic fluid in accordance with the applicable safety data sheet for the hydraulic fluid.

## NOTICE

### **Danger from chemical or corrosive environmental conditions!**

Product can be damaged! If the external gear unit is exposed to chemical or corrosive environmental conditions, such as sea water, fertilizer or road salt, it can result in corrosion or, in extreme cases, malfunction. Hydraulic fluid can escape if leaks occur.

- ▶ Take appropriate measures to protect the external gear unit from chemical or corrosive environmental conditions.

### **Escaping or spilling hydraulic fluid!**

Risk of environmental pollution and contamination of ground water!

- ▶ Always place a collecting pan under the external gear unit when filling and draining the hydraulic fluid.
- ▶ Use a suitable binding agent to collect any leaked hydraulic fluid.
- ▶ Observe the safety data sheet for the hydraulic fluid and the specifications provided by the machine/system manufacturer.

### **Environmental pollution from external leakage!**

External leakage at the external gear unit or oil leakage at an adjacent component during commissioning or operation can lead to environmental pollution.

- ▶ If the hydraulic fluid continues to leak at the external gear unit, contact your responsible Bosch Rexroth service partner.
- ▶ If residual oil leaks between the covers of multiple pumps, this does not result in any functional restriction. The oil leakage occurs just once and can be triggered by a temperature rise. It can occur during or after commissioning. Clean the external gear pump. Never use solvents or corrosive cleaning agents for this.
- ▶ Check if hydraulic fluid is leaking from an adjacent component and correct the cause of the fault.

### **Danger from hot components!**

Nearby products can be damaged! Components which heat up (e.g., solenoids) can cause damage to nearby products if they are too close during installation.

- ▶ When installing the external gear unit, check the safety distances to nearby products to ensure that they are not damaged.

The warranty only applies to the machine as delivered.

The entitlement to warranty cover will be rendered void if the product is incorrectly installed, commissioned or operated, or if it is used or handled improperly.

## 4 Scope of delivery

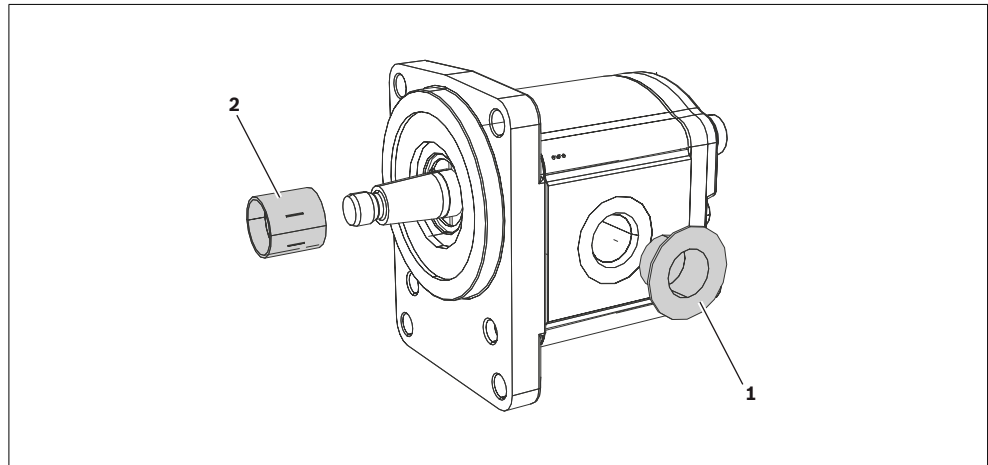

Fig. 1: External gear unit scope of delivery

The following is included in the scope of delivery:

- External gear unit with transport protection as per order confirmation
- Protective caps **(1)** for hydraulic connections
- Flange and shaft covers **(2)** (optional)

## 5 About this product

### 5.1 Performance description

An external gear pump converts mechanical energy (torque and rotational speed) into hydraulic energy (volumetric flow and pressure).

The external gear motor converts hydrostatic flow into mechanical rotation and controls or regulates this.

External gear pump and external gear motor are designed for mobile and stationary applications.

Refer to the data sheet and the order confirmation for the technical data, operating conditions and operating limits of the external gear unit.

### 5.2 Product description

The external gear unit consists essentially of a pair of gear wheels supported in bearing bushings/plain bearings and the housing with a front and a end cover. The drive shaft usually protrudes from the front cover where it is sealed by the shaft seal. The bearing forces are absorbed by slide bearings. These bearings were designed for high pressures and have excellent emergency running properties, especially at low rotational speeds. The gear wheels usually have 12 teeth. This keeps both flow pulsation and noise emission to a minimum.

The internal sealing of the pressure chambers is achieved by delivery pressure-dependent forces. This ensures optimum efficiency. On the rear side, the movable bearing bushings are pressurized with working pressure and pressed as seals against the gear wheels. The pressurized compression areas are limited by special seals. The seal in the area between the gear teeth and the housing is ensured by the smallest of gaps that adjust depending on the pressure between the gear teeth and housing.

#### 5.2.1 Layout of the external gear unit

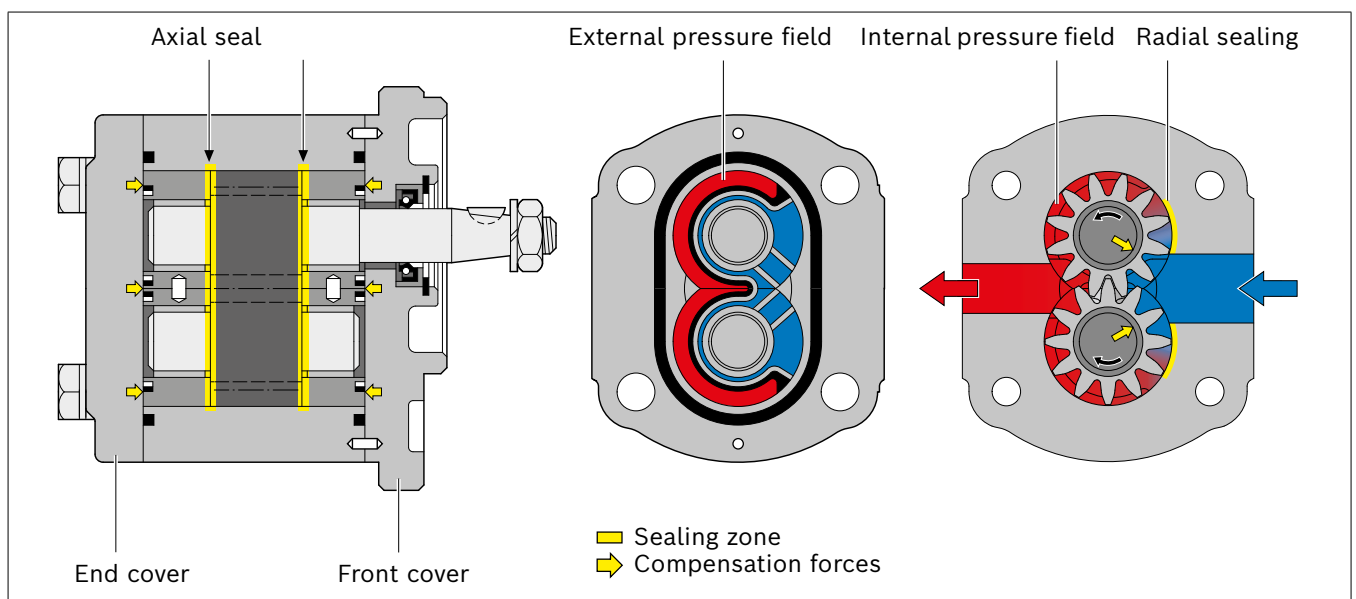

Fig. 2: Axial compensation external gear pump

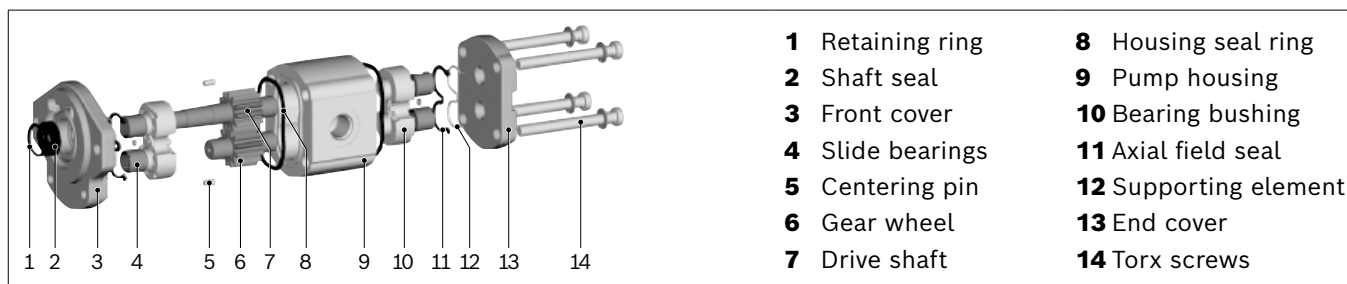

Fig. 3: External gear pump layout

### 5.2.2 Functional description

The range of Rexroth external gear units includes hydraulic pumps and motors. Refer to the technical data sheet or the offer drawing for the rotational speed and temperature range of the Rexroth external gear units.

#### External gear pumps

Rexroth external gear pumps are available in various series in which the displacements are graded by different gear wheel widths. Further configuration variants are given by different flanges, shafts, valve arrangements and multiple pump combinations; refer to the product-specific instruction manual for details.

External power is supplied on the driven gear wheel, which is turned by means of the gearing of the driven wheel. As the teeth chambers open, the hydraulic fluid is drawn in from the suction chamber via the pump inlet and transported through the gaps between the teeth in the two gearwheels to the pressure chamber. There, the meshing of the teeth forces the hydraulic fluid out of the gaps between the teeth, transporting it to the pump outlet.

#### External gear motors

Rexroth external gear motors are available in various series. Their displacements are graded by different gear wheel widths. The displacement principle of external gear motors is the opposite of that of pumps. For motors, configuration variants are given by different flanges, shafts, valve arrangements and integrated speed sensor. When hydraulic fluid is fed into the gear motor, torque will be available at the external shaft. A distinction is made between motors with one direction of rotation and reversible motors.

#### Gear motor for one direction of rotation

External gear motors for one direction of rotation have an asymmetrical structure, i.e. the high-pressure side and low-pressure side are fixed. Reversing operation is not possible. The case drain fluid which arises is drained internally. Pressure loading of the drain is limited due to the shaft seal.

#### Reversible gear motor

The reversible motors are characterized by a special feature. Due to their layout, the high-pressure and low-pressure chambers are separated from the bearing ring and shaft seal ring chamber. The case drain fluid which arises is drained via a separate case drain port. By means of this case drain fluid drainage, it is possible to load the motor on the return side. As a result, series connections are possible.

### 5.3 Product identification

The external gear unit can be identified from the name plate. Multiple pumps can be identified from the name plate of the first pump part (pump part with drive shaft). The following example shows an AZ name plate:

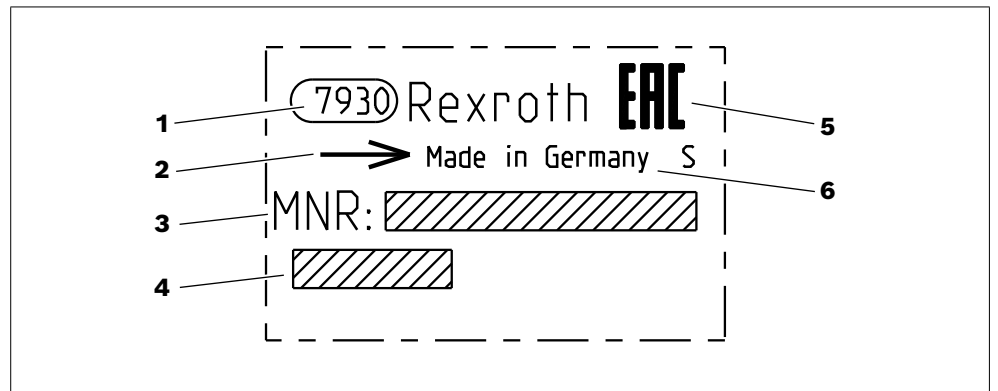

Fig. 4: Name plate

The name plate contains the following information:

- 1 Factory identifier
- 2 Direction of rotation - shown here: Clockwise rotational direction
- 3 Material number of the external gear unit
- 4 Manufacturing date
- 5 EAC mark
- 6 Standard marking, country of manufacture

### 5.4 Information on use at low temperatures

Observe the following limit values:

- Warm-up phase with low load from  $-40\text{ °C}$  and above
- Operating with loads from  $-30\text{ °C}$  (NBR seals) or  $-20\text{ °C}$  (FKM seals) and above

Also observe the following information:

- We recommend you use the NBR shaft seal ring variant for applications under  $-20\text{ °C}$ . However, with the NBR variant, there is a maximum operating temperature of  $80\text{ °C}$ .
- Avoid moisture in the area surrounding the external gear units as potential moisture on the shaft seal may freeze the sealing lip to the shaft when at a standstill. During start-up, we cannot rule out damage to the seal ring.
- The limit viscosities specified in the data sheets for the external gear unit must be adhered to by selecting a suitable hydraulic fluid over the entire operating time, both in winter and in summer with warmer temperatures.
- Particular attention must be paid to start-up viscosity. On pumps, there is an acute risk of cavitation when starting up with highly-viscous ("gel-like") hydraulic fluid in the suction line.
- When installing new components, these must be filled beforehand at higher temperatures so that a sufficient lubrication is assured in all areas.

## 5.5 Project planning notes

The following includes only a few, standard pieces of information. Bosch Rexroth is not responsible for correctness and completeness in individual cases.

We have included project planning notes for the following topics:

- Selection of hydraulic fluid
- Reservoir design
- Filter design
- Cooler
- Hose lines and piping
- Use under water
- Use with high ambient pressure



During design, observe the maximum possible application data from the relevant data sheets.

### Selection of hydraulic fluid

The hydraulic fluid in the hydraulic circuit must be selected very carefully during drive project planning in order to ensure fault-free, efficient operation of the system. Often it is not possible to meet all the requirements on hydraulic fluid to the same extent. Therefore, we recommend you weigh up the relative merits together with the hydraulic fluid vendor.

Also note the information in the "Hydraulic fluids based on mineral oils and related hydrocarbons (90220)", see table 1, page 7.

The viscosity/viscosity-temperature behavior have primary importance whereby the density and pour point must be observed.

Mineral oil basis fluids are suitable for use with external gear units. Its suitability depends, among other things, on the following factors:

- Wear properties
- Viscosity-temperature behavior
- Oxidation and corrosion protection
- Material compatibility
- Air separation ability (ASA)
- Water separation capability (WSC)



**Reservoir design**

The reservoir must be generously proportioned due to the thermal balance.

An initial estimate of the reservoir volume  $V$  (in  $l$ ):

- For mobile systems:  $V = 0.25 \dots 0.4 \cdot Q + 1.25 \cdot EZ$ , whereby
  - $Q$  is the numerical value for the pump suction volume (in  $l/min$ ) and
  - $EZ$  is the sum of the filling volumes of all cylinders (in  $l$ ).
- For stationary systems:  $V = 3 \dots 5 \cdot Q$

Also take into account an air space of 10 to 15 % of the hydraulic fluid volume.



Attach a sign on a prominent position of the reservoir which marks the reservoir as a hydraulic fluid reservoir. Also indicate the specification, volume, and replacement intervals for the hydraulic fluid. Add information about the filter change intervals and the names of the replacement filter cartridges.

Make sure that the reservoir filling process can only be performed using a permanently installed filter. New hydraulic fluid from new containers is normally contaminated.

<b>Ground clearance</b>	Make sure the ground clearance is at least 15 cm to ensure good heat dissipation.
<b>Drain option</b>	Temperature fluctuations cause condensation water to build up in the reservoir. This water and contaminants must be able to collect on the bottom-most part of the reservoir. Therefore, run the floor at a slope and provide a drain option at the lowest point.
<b>Baffles</b>	Provide baffles to prevent turbulent disruptions in the reservoir and to promote dirt deposit and air separation.
<b>Breather filter</b>	Make sure the provided air filter has the same filter grade as the system filter.
<b>Hydraulic fluid level monitoring</b>	Please note: a hydraulic fluid status check must be placed at a prominent position. Hydraulic fluid that escapes from leaky components is always contaminated and must not be fed back into the reservoir. Make an appropriate enhancement ahead of time so that the lowest hydraulic fluid level is never reached if at all possible.
<b>Suction line</b>	<p>The suction lines should be installed so that are approx. 5 cm over the reservoir bottom or, in case of a lateral exit, are this distance from the reservoir bottom. The entry diameter should be enlarged by means of an inclined gate and make an alignment to the oil flow-calmed side.</p> <p>Air can be drawn in through a suction line ending too close to the surface. For this reason, when determining the lowest level of hydraulic fluid, pay attention to the temporary removal of hydraulic fluid through cylinders as well as a potential inclined position of the system or machine.</p> <p>The negative pressure must not fall below 0.7 bar (abs.) (see the associated data sheet).</p>

**Drain lines** Direct the mouth of the drain lines in the reservoir below the minimum hydraulic fluid level. Make sure there is a sufficient cross section when combining several drain lines in a combination line.



For the reservoir design, ensure that there is an adequate distance between the suction line and the drain line. This prevents the heated return flow from being drawn directly back into the suction line.

### Filter design

Premature failures in external gear pumps are largely caused by contaminated hydraulic fluid. Since there is no warranty for wear caused by contamination, we recommend a filtration which reduces the degree of contamination to a permissible measure in terms of the size and concentration of the dirt particles:

**Table 6: Filtration**

Required cleanliness level	
ISO 4406	20/18/15

We recommend that a full-flow filtration always be used.

The filter manufacturer must provide evidence that the filter is functional and compliance with the required cleanliness level.

**Accessibility** In particular, make sure the filters are easily accessible to make maintenance work easier.

Add a contamination indicator to the filter where possible as well as a pressure-resistant filter element.

### Cooler

Air-oil or water-oil cooling in the drain lines is usually sufficient. The quantity of heat to be drained is based on the load and rotational speed of hydraulic components. Loading intervals and radiating surface are very important.

Check the temperature balance by taking temperature measurements during commissioning.

Arrange the air/oil heat exchangers to prevent them from lying in the vicinity of the warm exhaust air of the engine or working machine.

Provide a cooler bypass to protect the oil cooler during a cold start. This can be realized by installing a check valve or a thermal bypass valve.

Make sure the disks in air/oil heat exchangers are regularly de-dusted.

### Hose lines and piping

In hydraulics systems, hose lines are used to connect ports which move relatively to each other. Hose lines also help reduce the transmission of mechanical vibrations. Please note that the system and machine manufacturer is responsible for the design and installation of hose lines and piping in accordance with the standards.

In particular, the system/machine manufacturer must ensure that hose lines and fittings are designed to the maximum dynamic pressure of the pumps and motors as specified in the offer drawing, or as seen in dynamic measurements, or which could occur at the operator.

In this respect, we would like to draw your attention to EN standards for hoses and hose lines according to DIN EN 853-857 and their installation based on the safety instructions of the BIA in ZH 1/74.

Here is some additional information about the ports:

- To achieve favorable noise values, all connecting lines (suction, hydraulic- and drain ports) are to be decoupled from the reservoir using flexible elements.
- Route the leak back to the reservoir to keep the build-up of case pressure to a minimum.

**Use under water**

If the plan is to use the machine/system under water, get in touch with Bosch Rexroth before implementation during project planning (specific case assessment).

**Use at high ambient pressure**

If the plan is for use at an ambient pressure greater than 2 bar absolute, get in touch with Bosch Rexroth before implementation during project planning.

## 6 Transport and storage

- ▶ Always observe the required ambient conditions for transport and storage, see chapter 6.2 "Storing the external gear units" on page 25.



Information on unpacking can be found in chapter 7.1 "Unpacking" on page 32.

### 6.1 Transporting the external gear unit

The following transportation options are available depending on weight and the duration of transport:

- Transport by hand
- Transporting with a lifting device (eye bolt or lifting strap)

Use suitable transport containers (plastic containers, partly with grid separators) which meet the requirements and are free of damage.

#### Dimensions and weights

You can find dimensions and weights in the technical data sheets for the series concerned, and also in the offer drawings.

#### 6.1.1 Transport by hand

Up to a specific maximum weight, external gear units can be transported by hand for a short period of time. Observe the national regulations in your country. To prevent health damage, we recommend renouncing any transport by hand.

#### **CAUTION!** Risk of injury due to heavy loads!

Health hazard from carrying external gear units.

- ▶ Only manually transport the external gear unit for a short period of time. Observe the national regulations in your country for manual transport.
- ▶ Always use appropriate lifting, lowering and moving techniques.
- ▶ Use your personal protective equipment (e.g. safety goggles, safety gloves, suitable working clothes, safety shoes).
  
- ▶ Do not use sensitive assembled parts to transport the external gear unit (e.g. sensors or valves).
- ▶ Carefully place the external gear unit on the seating to prevent it from being damaged.

### 6.1.2 Transport with lifting devices

#### Transport with lifting strap

**WARNING!** Danger due to suspended loads!

During transportation with a lifting strap, the external gear unit can tip out of the strap and cause injuries.

- ▶ Use the widest possible lifting strap.
- ▶ Make sure that the external gear unit is securely fixed with the lifting strap.
- ▶ Only guide the external gear unit by hand for fine positioning and to avoid oscillations.
- ▶ Never stand or reach under suspended loads.
  
- ▶ Place the lifting strap around the external gear unit in such a way that it passes over neither the assembled parts (e.g. valves) nor such that the external gear unit is hung from attachment parts (see Fig. 5).

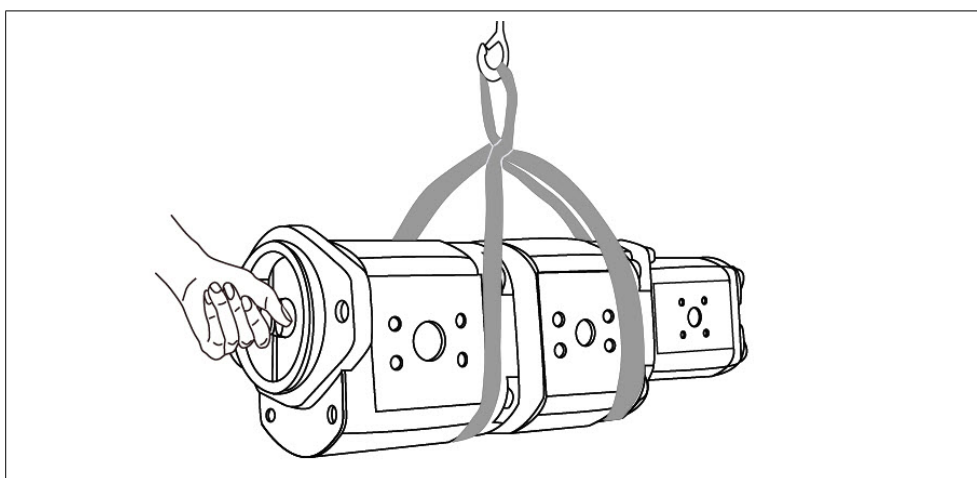

Fig. 5: Transport with lifting strap

### 6.2 Storing the external gear units

#### Requirement

When storing the external gear units for a longer period of time or when removing it from the machine/system and not installing it again, you must preserve it from corrosion during its time in storage.

- The storage areas must be free of corrosive materials and gases.
- To prevent damage to the seals, do not operate ozone-forming equipment (e.g. mercury-vapor lamps, high-voltage equipment, electric motors, sources of electrical sparks or electrical discharge) in storage areas.
- Storage areas should be dry. Recommended relative humidity  $\leq 60\%$ .
- Ideal storage temperature:  $+5\text{ °C}$  to  $+20\text{ °C}$ .
- Minimum storage temperature:  $-50\text{ °C}$ .
- Maximum storage temperature:  $+60\text{ °C}$ .
- Keep out of direct sunlight.
- Do not stack external gear units and store them in a shock-proof manner.
- Do not store the external gear unit on the drive shaft or assembled parts, e.g. sensors or valves.
- For further storage conditions, see Table 7.
  
- ▶ Check the external gear unit monthly to ensure proper storage.

**After delivery** The external gear units come with a corrosion protection packaging (corrosion protection film) provided at the factory. The active agent, which comes out of the corrosion protection film towards the inside, is deposited on the metal surface and forms a layer separating the material and electrolyte (water vapor).

**Table 7: Storage time with factory corrosion protection**

Storage conditions	Standard corrosion protection	Long-term corrosion protection
Closed, dry room, at a consistent temperature between +5 °C and +20 °C. Undamaged and sealed corrosion protection film.	Maximum 12 months	Maximum 24 months



Warranty entitlement will be rendered void if the requirements and storage conditions are not adhered to or after expiration of the maximum storage time of two years.

How to proceed once the max. storage time elapses:

1. Check the entire external gear unit for damage and corrosion prior to installation.
2. Perform a test run to check the external gear unit for proper function and leak-tightness.
3. If storage time exceeds 24 months, replace the shaft seal.



After expiration of the maximum storage time, we recommend that you have the external gear unit inspected by your Bosch Rexroth service partner.

In the event of questions regarding repair and spare parts, contact your responsible Bosch Rexroth service partner or the service department of the manufacturer's plant for the external gear unit, see chapter 10.5 "Spare parts" on page 51.

**After removal** A dismantled external gear unit must be stored with corrosion protection for the duration of storage.



The following instructions only refer to external gear units which are operated with a hydraulic fluid based on mineral oils. Other hydraulic fluids require other specific preservation measures. In such cases, please consult us. The address of your local contact person can be found at [www.boschrexroth.com/addresses](http://www.boschrexroth.com/addresses)

Bosch Rexroth recommends the following procedure:

1. Clean the external gear unit, see chapter 10.1 "Cleaning and care", on page 50.
2. Empty the external gear unit.
3. For storage times up to 12 months: Coat the inside of the external gear unit with mineral oil and fill with approx. 100 ml mineral oil.  
For storage times up to 24 months: Fill the external gear unit with corrosion protection VCI 329 (10 to 20 ml).
4. Plug all ports so they are airtight.
5. Moisten the unpainted areas of the external gear unit with mineral oil or suitable, easily removable corrosion protection, e.g. acid-free grease.

- 6. Package the external gear unit with desiccant in corrosion protection film so it is airtight.
- 7. Store the external gear unit in a non-explosive area in a manner that is shock-proof, see "Requirement" on page 29 in this chapter.

When storing external gear units, pay attention to the following instructions taking internal and external corrosion protection measures into account. The external gear unit must not be stored under less favorable conditions than indicated in the table.

**Table 8: Storage conditions external gear units**

Storage conditions	Storage period	
	Up to 12 months	12 to 24 months
Closed, dry room, at a consistent temperature between +5 °C and +20 °C. Undamaged and sealed corrosion protection film.	<b>Protection process</b>	
	Empty the external gear unit and fill in approx. 100 ml of mineral oil. Plug all ports so they are airtight. Package the external gear unit in corrosion protection film so that it is airtight. (Standard protection procedure)	Empty the external gear unit and fill with approx. 10 to 20 ml of corrosion protection agent VCI 329. Plug all ports so they are airtight. Package the external gear unit in corrosion protection film so that it is airtight.

## 7 Installation

Prior to installation, the following documents should be to hand:

- Data sheet of the external gear unit (contains the permissible technical data, main dimensions and circuit diagrams of standard versions)
- Offer drawing for external gear unit (can be obtained from your contact at Bosch Rexroth)
- Hydraulic circuit diagram for the external gear unit (can be found in the offer drawing)
- Hydraulic circuit diagram for the machine/system (available from the machine/system manufacturer)
- Order confirmation (contains the order-related technical data for your external gear unit)

### 7.1 Unpacking

The external gear unit is delivered in a corrosion protection film made of polyethylene material (PE).

**CAUTION!** Danger due to falling parts!

If the packaging is not opened correctly, parts may fall out and damage the parts or even result in injury.

- ▶ Place the packaging on a level underground with sufficient load-bearing capacity.
- ▶ Only open the packaging from the top.
  
- ▶ Remove the packaging from the external gear unit.
- ▶ Check the external gear unit for transport damage and completeness, see chapter 4 "Scope of delivery" on page 20.
- ▶ Dispose of the packaging in accordance with the regulations in your country.



The external gear unit is usually packed with grease paper (paraffin paper). To help the environment, Bosch Rexroth uses reusable packaging for the external gear unit which is usually the property of Bosch Rexroth. Always observe the valid regulations when disposing of the packaging of the external gear unit.



## 7.2 Installation conditions

- ▶ Fasten the external gear unit so that the expected forces and torques can be transferred without any danger. The machine/system manufacturer is responsible for sizing the fasteners.
- ▶ Observe the permissible radial forces on the drive shaft when transferring output drive with radial force loading (belt drives). If necessary, store the belt pulley separately.
- ▶ Make sure that the external gear unit is air bled and filled with hydraulic fluid during commissioning and operation. Do this also after relatively long standstill periods, since the external gear unit may drain through the hydraulic lines.
- ▶ A check valve in the drain line is only permissible on a case-by-case basis following consultation. Please consult your proper contact person at Bosch Rexroth.
- ▶ To keep noise values low, use elastic elements to isolate all connecting lines from all vibration-capable components (e.g. reservoir).
- ▶ Make sure the suction, drain, and return lines flow into the reservoir below the minimum fluid level under all operating conditions. This will prevent air from being drawn in and foam from being formed.
- ▶ Make sure that the working environment at the installation site is completely free of dust and foreign substances. The external gear unit must be installed in clean condition. Contamination of the hydraulic fluid can considerably affect the function and service life of the external gear unit and its suitability for use in explosive areas.
- ▶ Use fiber-free cloths for cleaning.
- ▶ Use suitable mild cleaning agents to remove lubricants and other difficult-to-remove contamination. Do not allow cleaning agents to enter into the hydraulic system.
- ▶ Do not use hemp or cement as sealant under any circumstances.
- ▶ Cover the shaft seal ring when applying paint with a spray or brush.

## 7.3 Installation position

The installation location and position of the external gear unit essentially determine the procedures during installation and commissioning (such as when filling the external gear unit).

Note the information in the relevant data sheet, see Table 1 on page 7.

The following applies for all installation positions:

- During commissioning and operation, the housing of the external gear unit must be filled and remain filled with hydraulic fluid.
- To achieve favorable noise values, all connecting lines (suction, hydraulic- and leak ports) are to be decoupled from the reservoir using flexible elements.



With pumps, generally for all installation positions, a minimum suction pressure is required at port **"S"**: minimum suction pressure  $\geq 0.7$  bar abs (for other values, refer to the technical data sheet).

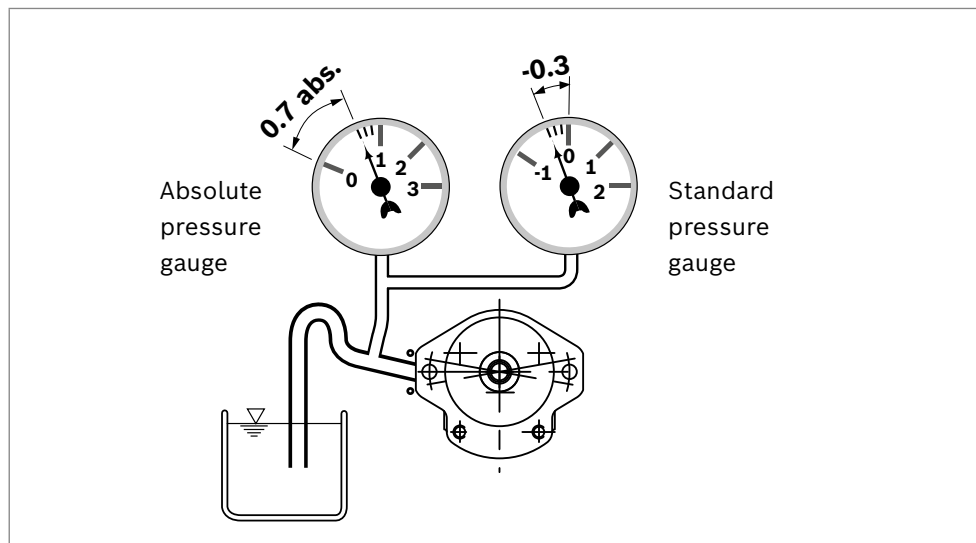

Fig. 6: Suction pressure

**CAUTION!** Risk of damage if the hydraulic fluid supply is too low

The external gear unit must always be completely filled with hydraulic fluid.

- ▶ During commissioning, make sure the external gear unit is supplied completely with hydraulic fluid.
- ▶ Always ensure that the entire hydraulic system is leak-proof.
- ▶ If there is an unusual build-up of noise or vibrations, immediately switch off the machine or system and check to see whether the external gear unit is filled with hydraulic fluid.
- ▶ Provide an additional pressure relief valve to prevent a possible bursting if there is excess pressure in the system.

## 7.4 Installing the external gear units

### 7.4.1 Preparation

1. Check the delivery contents for transport damages.
2. Compare the material number and designation (type code) with the parameters in the order confirmation.



If the material number for the external gear unit does not match the one in the order confirmation, contact your local contact person for clarification. You can find their contact information under [www.boschrexroth.com/addresses](http://www.boschrexroth.com/addresses)

3. Before installing, completely empty the external gear unit to prevent mixing with the hydraulic fluid used in the machine/system.
4. Check the direction of rotation of the external gear unit (on the name plate) and make sure that this corresponds to the direction of rotation of the drive motor and the negative buoyancy of the power consumer (clockwise pump to anti-clockwise motor, and vice versa).

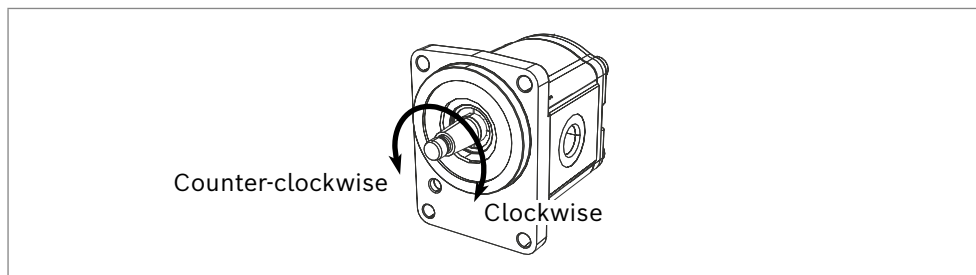

Fig. 7: Direction of rotation



The direction of rotation as specified on the name plate, see chapter 5.3 "Identification of the product" on page 23 is the direction of rotation of the external gear unit as viewed to the drive shaft.

#### 7.4.2 Dimensions

The offer drawing contains the dimensions for all ports on the external gear unit. Also observe the manuals provided by the manufacturers of the other hydraulic components when selecting the required tools.

#### 7.4.3 General instructions

Follow these general instructions when installing the external gear unit:

- Fasten the external gear unit so that the expected forces and torques can be transferred without any danger.
- The permissible loads with respect to pressure and minimum and maximum speeds can be found in the relevant technical data sheet and offer drawing. For axial and radial loading, see chapter 5.5. "Project planning notes" on page 24. The customer must check for the appearance of radial and axial forces during the project planning program.
- **Toothed belts** lose a major portion of their pre-tension after a short operating time and thus cause speed variations and torsional vibrations. Torsional vibrations may cause leakages on the shaft seal ring of the driven external gear unit. Particularly at risk are diesel drives with a small number of cylinders and low flywheel weight. Bosch Rexroth recommends you avoid this type of toothed belt drive or equip it with an automatic clamping device.
- **V-belt drives** without automatic clamping device are also critical with regard to speed variations and torsional vibrations. These can also lead to leakages on the shaft seal ring. An automatic clamping device can lessen the speed variations and vibrations and thus avoid consequential damage. Bosch Rexroth recommends with automatic V-belt drives with clamping devices only.
- In both kinds of belt drives, the permissible radial forces on the shaft shall be followed and verified during project planning. If necessary, store the belt pulley separately.
- Assembly of the drive and output drive elements is carried out by pulling onto the drive shaft with the aid of the threaded spigot in the drive shaft end.
- Gear drives see chapter 5.5 "Project planning notes" on page 24.

**CAUTION!** Risk of injury

During assembly of the external gear unit, injuries may arise especially crushing, cuts, etc. in the pump adjustment area.

- ▶ Use appropriate aids to remove the external gear unit from the packaging and follow ergonomic guidelines.
- ▶ Wear your personal protective equipment.
- ▶ Perform assembly properly with care.

**CAUTION!** Risk of damage

Malfunctions, leaks and increased wear are possible due to incorrect tightening torques.

- ▶ During attachment, make sure on the external gear unit that the tightening torque on the through-bolt joints is correct.

The installation method for the external gear unit depends on the connecting elements to the input or output side. The following descriptions explain the installation of the external gear unit:

- Via a coupling
- Via a gearbox

**7.4.4 Installation with a coupling**

How to install the external gear unit with a coupling is described in below:

**NOTICE!** Danger from improper handling! Product can be damaged!

- ▶ Do not install the coupling hub onto the drive shaft of the external gear unit by striking it.
1. Install the specified coupling half onto the drive/output shaft of the external gear unit according to the instructions of the coupling manufacturer. No radial or axial forces are permitted to act on the shaft or coupling sleeve.



Generally pay attention to complying with the maximum torques which you can get from the relevant Y sheets and data sheets.

On elastic couplings, note:

- The maximum radial runout deviations from the shaft to the spigot may not exceed 0.2 mm.
- See the coupling manufacturer's assembly instructions for permissible shaft misalignment tolerances.



The drive shaft of the external gear unit is equipped with a female thread. Use this female thread to pull the coupling element onto the drive shaft. The size of the female thread can be seen in the offer drawing.

On coupling sleeves, note:

- The coupling sleeve must be free to move axially.
- Keep the distance between the drive shaft and output shaft (see technical data sheet).
- Oil-bath or oil-mist lubrication is required.

2. Make sure that the installation location is clean and free from dirt and contaminants.
3. Clamp the coupling hub onto the drive shaft or ensure permanent lubrication of the drive shaft. This prevents the formation of frictional corrosion and the associated wear.
4. Transport the external gear unit to the installation location and install the coupling onto the drive or output drive according to the instructions of the coupling manufacturer.  
Note: Only firmly screw the external gear unit after the coupling was correctly mounted.
5. Fasten the external gear unit at the installation location. Details of the required tools and tightening torques for the mounting bolts can be obtained from the machine/system manufacturer.
  - a) For **bell housing installation**, check the coupling axial play through the bell window according to the manufacturer's specifications.  
The external gear unit must not be tightened down until the coupling has been correctly installed.
  - b) For **flange installation**, align the support for the external gear unit for a drive or output drive.

**CAUTION!** Risk of injury by tearing the shaft

Over-tightening screw nuts when assembling the coupling halves can cause the shaft to tear. Persons can be injured.

- Only tighten the screws with torque wrench and suitable to the set torque.



Prevent frictional corrosion on the coupling components by permanent lubrication.

#### **When installing using coupling dogs**

Coupling dogs and drivers are used for direct installation of the external gear unit to a drive motor, a gearbox, etc.

Plug-in connections (coupling dogs) of the drive shaft are to be protected from frictional corrosion (permanent lubrication).

Through concealed installation, after installation of the external gear unit, it can no longer be checked whether the spigot diameter centers the external gear unit (note tolerances) or whether axial or radial forces apply to the drive shaft of the external gear unit (installation length). The check must therefore be done before installation and during assembly.

For installation and sealing, pay attention to the recommendations from the technical data sheet.

#### **When installing using gear wheels and V-belts**

When driving through V-belts/gear wheel, please get in touch with Rexroth. Indicate the operating conditions and mounting situations.

External gear units with outboard bearing are offered to eliminate possible problems when the pumps are driven by V-belts or gear wheels.

### 7.4.5 Completing installation

Remove the transport protection.

The external gear unit is delivered with protective covers and protective plugs.

They are not pressure-resistant and have to be removed prior to connection.

Use a suitable tool for this to prevent damage to the sealing and functional surfaces.

If sealing or functional surfaces are damaged, contact your Bosch Rexroth service partner or the service department of the manufacturer's plant for the external gear unit.

#### **CAUTION!** Operation with protective plugs!

Operating the external gear unit with protective plugs may result in injuries or damage to the external gear unit.

- ▶ Before commissioning, remove all protective plugs and replace them with suitable, pressure-resistant, metal threaded plugs or connect the appropriate lines.



Ports intended for connecting lines come with protective plugs and/or threaded plugs, which serve as transport protection. All ports required for the function must be connected. Failure to do so could lead to malfunctions or damage.

If a port is not being used, plug it with a threaded plug since the protective plugs are not pressure-resistant.

#### **WARNING!** Danger through contamination and injury

The contact with residual amounts of hydraulic fluid or preservative agent in the housing can damage your health (e.g. allergies, eye injuries, skin and tissue damage, toxication through inhalation).

- ▶ When removing stoppers, wear safety gloves and safety goggles.
- ▶ If hydraulic fluid or preservative agent should, nevertheless, come into contact with your eyes or penetrate your skin, consult a doctor immediately.
- ▶ When working with operating and preservative agents, strictly observe the manufacturer's safety instructions (safety data sheet).



Sealing rings and sealing surfaces can be damaged if the transport protection is not removed properly.

Also observe the following information:

- Do not damage the sealing surfaces.
- Connect hoses and pipes to all ports and seal them with threaded plugs in accordance with the hydraulic circuit diagram.
- The working ports and function ports are only intended to install hydraulic lines (see "Connect lines" below).

**7.4.6 Hydraulically connecting the external gear unit****NOTICE****Insufficient suction pressure!**

Generally, a minimum permissible suction pressure at port **S** is specified for external gear pumps in all installation positions. If the pressure at port **S** drops below the specified values, damage may occur which may lead to the external gear pump being damaged beyond repair!

- ▶ Make sure the required suction pressure is maintained.

This is influenced by:

- The piping (e.g. suction cross-section, pipe diameter, length of suction line)
- The position of the reservoir
- The viscosity of the hydraulic fluid
- A filter element or check valve in the suction line (check the level of contamination of the filter element regularly)
- The geodesic height of the place of use

The machine/system manufacturer is responsible for dimensioning of the lines. The external gear unit must be connected to the rest of the hydraulic system in accordance with the hydraulic circuit diagram of the machine/system manufacturer. The ports and fastening threads are designed for the maximum pressure specified in the data sheet. The machine/system manufacturer is required to ensure that the connecting elements and lines correspond to the specified application conditions (pressure, flow, hydraulic fluid, temperature) with the necessary safety factors.



Connect only hydraulic lines that are appropriate for the external gear unit port (pressure level, size, system of units).

**Information on routing of lines**

Observe the following information when routing the suction, pressure and drain lines.

- Lines and hoses must be installed without pre-charge pressure, so that no further mechanical forces are applied during operation that will reduce the service life of the external gear unit and, if applicable, the entire machine/system.
- Use suitable seals as sealing material.
- Suction line (pipe or hose)
  - The suction line should be as short and straight as possible.
  - Measure the line cross section of the suction line so that the pressure at the suction port does not drop below the minimum permissible pressure. Make sure the maximum suction pressure is not exceeded (e.g. when prefilling).
  - Make sure the connections and connecting elements are airtight.
  - The hose must be pressure-resistant, also for external air pressure.
- Pressure line
  - Ensure sufficient burst resistance of the pipes, hoses and connecting elements must be ensured for pressure lines.
- Install drain lines so that the housing is constantly filled with hydraulic fluid and to ensure that no air gets through the shaft seal even during extended standstill periods. Under no operating circumstances may the case pressure exceed the maximum limit values specified for the external gear unit in the data sheet.

- If the external gear unit is equipped with installed fittings, these must not be unscrewed. Screw the stud end of the fitting directly into the installed fitting.

**Risk of confusion with threaded connections**

External gear units are employed in application areas that use the metric measuring system as well as the Anglo-American (imperial) and the Japanese measuring system (JIS – **J**apan **I**ndustrial **S**tandard). Various kinds of seals are also used. The system of units, the kind of seal and the size of female thread and stud ends (e.g. threaded plug) must all match. There is a risk of confusion due to the limited ways of visually telling them apart.

**WARNING!** Leaky and bursting stud ends!

For fittings, if a stud end that does not match the system of units, kind of seal and size of the female thread is pressurized, the stud end may loosen itself or even be ejected from the hole in a projectile-like manner. This can result in serious injury and property damage. Hydraulic fluid can escape from this leakage point.

- ▶ Use the drawings (offer drawing) to determine the required stud end for each fitting.
- ▶ Make sure the right fittings, mounting bolts and threaded plugs are installed.
- ▶ For all female threads, use a stud end from the same system of units and of the correct size.

**Fittings**

Note the following information to prevent damage to the screws and threads.

**Risk of confusion**

Due to missing, visual differentiation, there is a danger of mixing up the following tapped holes and threaded plugs of different dimension systems:

**Table 9: Risk of mixing up female thread UN – UNF thread with threaded plug metric or with pipe thread**

<b>Female thread Thread type</b>	1/2-20 UNF	9/16-18 UNF	3/4-16 UNF	7/8-14 UNF	1 3/16-12 UN	1 5/16-12 UN
Risk of mixing up with threaded plug	M12 x 1.5	M14 x 1.5	M18 x 1.5	G 1/2	M30 x 2	M33 x 2

**Table 10: Risk of mixing up female thread with metric fine thread with threaded plugs UN, UNF and pipe thread**

<b>Female thread Thread type</b>	M8 x 1	M10 x 1	M12 x 1.5	M14 x 1.5	M20 x 1.5	M22 x 1.5	M42 x 2	M48 x 2
Risk of mixing up with threaded plug	5/16-24 UNF	G 1/8 3/8-24 UNF	7/16-20 UNF	G 1/4	3/4-16 UNF	G 1/2	1 5/8-12 UN	1 7/8-12 UN

**Table 11: Risk of mixing up female pipe thread with threaded plugs UN, UNF and metric pipe thread**

<b>Female thread Thread type</b>	G 1/8	G 1/4	G 3/8	G 1/2	G 1 1/4
Risk of mixing up with threaded plug	3/8-24 UNF	1/2-20 UNF	M16 x 1.5	M20 x 1.5	1 5/8-12 UN



**Procedure** To connect the external gear unit to the hydraulic system:

**1.** Remove the transport locks (if not done already).

**2.** Clean the lines.

Contamination in the hydraulic fluid can have a considerable impact on the service life of the external gear unit. The lines must be cleaned before installation.

**3.** Secure the lines according to the instructions of the machine manufacturer.

Either pipes or hoses must be connected to all ports according to the offer drawing and machine or system circuit diagram or the ports plugged using suitable threaded plugs.

Comply with the information of the offer drawing and the manufacturer on the permissible tightening torques of the fittings used. For mounting bolts according to DIN 13/ISO 68, we recommend checking the tightening torque in individual cases as per VDI 2230.

**4.** Make sure

– that the union nuts on the fittings and flanges are tightened correctly (observe the manufacturer's tightening torque!). Mark all checked fittings using e.g. a permanent marker pen.

– that the pipes and hose lines and every combination of connecting piece, coupling or connecting point with hoses or pipes have been inspected by a technically qualified person for safe working condition.

**Tightening torques for customer fittings**

The following tightening torques for the customer fittings to external gear motors and -pumps are to be considered maximum admissible values. If the screw fitting manufacturer requires lower values, these shall apply.

For thread sizes not shown, please contact Bosch Rexroth.

The information applies for technically standard surfaces of mounting bolts (come delivered slightly oiled; total friction coefficient  $\mu_{\text{total}} = 0.1$ ; recommended property class 10.9).

If divergent values apply in the offer drawing, these shall have priority.

Torque information apply for nut threads on the pump housing and on the end cover (usually aluminum or cast iron).

**Table 12: Tightening torques for customer fittings**

Thread	Tightening torque [Nm] ±10 %	Min. load-bearing screw-in depth [mm]	Remarks (value/type AZP and AZM)	Code (hydraulic ports)
G1	381	17		01
G3/4	217	15		01
G1/2	117	13		01
G3/8	60	10		01
G1/4	37	9		01
1-11 1/2 NPTF	81	–	–	XX
3/4-14 NPTF	68	17	F, S	XX
1/2-14 NPTF	54	19.6	B	XX
1 7/8-12 UN	427	16	G-1x	12
1 5/8-12 UN	332	16	N, T, G-1x	12
1 5/16-12 UN	285	16	N, T, G-22, U	12
1 1/16-12 UN	176	16//13,6	F, S, G-22, U // N, T	12
7/8-14 UNF	103	13.6	N, T	12
3/4-16 UNF	77	11	F, S	12
9/16-18 UNF	34	16/9,7	B / F, S	12
1/2-20 UNF	26	–	–	12
7/16-14 UNC	58	15	G-22, U	12
3/8-16 UNC	28//34//39	11//13//15	N, T // G-1x // G-22, U	12
5/16-18 UNC	20	10	F, S	12
1/4-20 UNC	14	10	F, S	12
M42x2	599	17		03
M33x2	333	15		03
M27x2	237	16		03
M26 x 1,5	80	7		03
M22 x 1,5	101	11		03
M18 x 1,5	65	10		02, 03
M16 x 1,5	55	10		02, 03
M14 x 1,5	41	9		02, 03
M12 x 1,5	44	11.5		02, 03
M12	98	20		07, 20, 30
M10	38//46//54	11//13//15	F, S, N, T//G-1x//G-22, U	07, 20, 30
M8	21	10		07, 20
M6	12	10		20, 30
M14	100	21	G-22, U	Pump screwed diagonally onto the customer connection.
M10	55	15	F, S, N, T, G-1x	Pump screwed diagonally onto the customer connection.
M8	28	12	B	Pump screwed diagonally onto the customer connection.

#### 7.4.7 Performing flushing cycle

In order to remove foreign particles from the system, Bosch Rexroth recommends a flushing cycle for the hydraulic system before the first commissioning.



During the flushing cycle, the external gear unit must be operated without load.

The flushing cycle can be performed, e.g. by using an additional flushing unit. Follow the instructions of the flushing unit's manufacturer for the exact procedure during the flushing cycle.

To assure the hydraulic fluid has the required cleanliness, pay attention to the following:



The finer the filtration, the higher the cleanliness level of the hydraulic fluid and the longer the service life of the external gear unit.

To ensure the functional reliability of the external gear unit, cleanliness level 20/18/15 according to at least ISO 4406 is necessary for the hydraulic fluid. Please contact Bosch Rexroth if the above classes cannot be observed.

## 8 Commissioning

This chapter describes how to commission the external gear unit. Follow the instructions in this chapter if you:

- are commissioning the external gear unit for the first time;
- are going to recommission the external gear unit after a period of downtime with an empty suction line.
- are going to recommission the external gear unit after a longer period of downtime (> 6 months).

Please note:

Within the sense of the Machinery Directive 98/37/EC, the external gear unit is a component which is designed for installation in a machine or system.

Commissioning is not permitted until it has been established that the machine or system in which this product is built meets the provisions of the EU guidelines and all the other applicable guidelines.

Note the following safety instructions when commissioning:

### **WARNING**

#### **Danger while working in the danger zone of a machine/system!**

Danger to life, risk of injury or serious injury!

- ▶ Pay attention to and eliminate potential sources of danger before commissioning the external gear unit.
- ▶ Make sure no one is in the danger zone of the machine/system.
- ▶ The emergency stop button for the machine/system should be within the operator's reach.
- ▶ Always follow the instructions of the machine/system manufacturer during commissioning.

### **WARNING**

#### **Danger due to startup of the fan wheel or from the running fan wheel!**

Danger to life or risk of injury!

During startup, the fan wheel may already be running. While in the area of the rotating fan wheel there is risk of being caught-up due to the suction effect.

- ▶ Do not stand in the danger zone of the running fan wheel.
- ▶ Before entering the danger zone, ensure the fan wheel has stopped, e.g. by disconnecting the drive source.

**ATTENTION:** Pulling out the plug does not lead to a safe condition, but actually leads to the fan wheel turning at maximum speed

- ▶ The machine manufacturer must test the application to see whether additional protective measures are required.

**CAUTION****Commissioning an improperly installed product!**

Risk of injury and property damage!

- ▶ Make sure all electrical and hydraulic ports are connected or plugged.
- ▶ Commission only a fully installed, fully functioning product with original accessories from Bosch Rexroth.

**NOTICE****Increased wear and malfunction due to contamination of the hydraulic fluid**

Property damage!

- ▶ Make sure no hard foreign particles such as welding beads or metal cuttings can get into the suction line of the external gear unit.
- ▶ Ensure the utmost cleanliness during commissioning.
- ▶ Be sure to inspect the hydraulic system before commissioning.

**NOTICE****Risk of damage**

Commissioning or recommissioning without or with too little hydraulic fluid levels in the housing area can lead to damage or immediate destruction of the external gear unit.

- ▶ When commissioning or recommissioning a machine or system, make sure that the entire housing area of the external gear unit and the suction and working lines of the are filled with hydraulic fluid and remain filled during operation.

**8.1 Initial commissioning**

During all work for commissioning the external gear unit, observe the general safety instructions and intended use detailed in chapter 2 "Safety instructions" on page 11.

**Preparation**

Before beginning with commissioning of the external gear unit, make sure all the necessary precautions have been taken and all equipment has been prepared.

**Required tools**

You need a suitable tool:

The offer drawing contains the dimensions for all ports on the external gear unit. Also observe the manuals provided by the manufacturers of the other hydraulic components when selecting the required tools.

**Hydraulic fluid required**

The machine or system manufacturer can provide you with precise details on the hydraulic fluid.

### 8.1.1 Filling the external gear unit

Professional filling and air bleeding is necessary to prevent damage to the external gear unit and to maintain correct function.



Usually, the cleanliness level of commercial hydraulic fluids is insufficient for our components. These hydraulic fluids must be filtered during filling using an appropriate filter system to minimize solid particle contamination and water in the system.

Use only a hydraulic fluid that corresponds to the following requirements: You can find details on the minimum requirements for hydraulic fluids in Bosch Rexroth data sheets 90220, 90221, 90222, and 90223. The titles of the data sheets can be found in Table 1 "Required and supplementary documentation" on page 7.



Bosch Rexroth evaluates hydraulic fluids on the basis of the Fluid Rating according to data sheet 90235. For hydraulic fluids which have been positively evaluated in the Fluid Rating, please refer to data sheet 90245 "Bosch Rexroth fluid rating list for Rexroth hydraulic components (pumps and motors)". The hydraulic fluid should be selected so that the operating viscosity in the operating temperature range is within the optimum range ( $v_{opt}$ ; see selection diagram in the corresponding data sheet).

To ensure the functional reliability of the external gear unit, cleanliness level 20/18/15 according to at least ISO 4406 is necessary for the hydraulic fluid. Please contact Bosch Rexroth if this level cannot be met. For permissible temperatures, see the data sheet.

Observe the following when filling the hydraulic system:



If there is an unusual build-up of noise or vibrations, immediately switch off the machine or system and check to see whether the external gear unit is filled with hydraulic fluid.

The external gear unit must not be operated while it is being filled.  
The lines must be filled.

**Procedure** To fill the external gear unit with hydraulic fluid, proceed as follows:

1. Place a drip tray under the external gear unit to collect any hydraulic fluid that may leak.
2. Use the highest port for bleeding.
3. Make sure that all other ports are either connected to pipes or plugged according to the overall circuit diagram.  
Remove existing plugs as necessary.
4. Completely fill the external gear unit with hydraulic fluid.
5. Close the port again.

### 8.1.2 Testing the hydraulic fluid supply

The external gear unit must always have a sufficient supply of hydraulic fluid. For this reason, the supply of hydraulic fluid must be ensured at the start of the commissioning process.

When you test the hydraulic fluid supply, constantly monitor the noise development and check the hydraulic fluid level in the reservoir. If the external gear unit becomes louder (cavitation) or the hydraulic fluid is discharged with bubbles, this is an indication that the external gear unit is not being sufficiently supplied with hydraulic fluid.

Notes on troubleshooting can be found in chapter 14 "Troubleshooting" on page 55.

To test the hydraulic fluid supply:

1. Start the external gear unit without load and let it run depressurized for a few minutes in order to ensure sufficient lubrication.  
Pay attention to leaks and noises.
2. Should the pump not displace bubble-free oil after approx. 2 minutes, re-check the system.
3. After the operating values have been reached, check the pipe connections for leakage.
4. Check the operating temperature.

### 8.1.3 Performing a functional test

#### **WARNING**

##### **Improperly connected external gear unit!**

Mixing up the ports will cause malfunctions (e.g. lift instead of lower) and could endanger personnel and equipment!

- ▶ Before the functional test, check whether the piping specified in the hydraulic circuit diagram has been installed.

Once you have tested the hydraulic fluid supply, perform a functional test of the machine/system. The functional test should be performed according to the instructions of the machine/system manufacturer.

The external gear unit is tested for functional capability and performance before delivery according to the technical data. During commissioning, it must be ensured that the external gear unit was installed properly in the machine/system.

- ▶ After starting the drive motor, check in particular the specified pressures, e.g. working pressure and suction pressure.
- ▶ Perform a leak test without and with load prior to normal operation.
- ▶ If necessary, remove the pressure gauge and plug the ports with the specified threaded plugs.

## 8.2 Running-in phase

### NOTICE

#### Property damage due to insufficient viscosity!

Elevated hydraulic fluid temperature may excessively reduce viscosity and damage the product!

- ▶ Monitor the operating temperature during the running-in phase, e.g. by measuring the hydraulic fluid temperature in the reservoir.
- ▶ Reduce the loading (pressure, rotational speed) of the external gear unit if impermissible operating temperatures and/or viscosities occur.
- ▶ Excessively high operating temperatures indicate faults that have to be analyzed and eliminated.

The bearings and sliding surfaces are subject to a running-in phase. The increased friction at the start of the running-in phase results in increased heat development which decreases with increasing operating hours. The volumetric and mechanical-hydraulic efficiency increases as well through the conclusion of the running-in phase of approx. 10 operating hours.

To ensure that contamination in the hydraulic system does not damage the external gear unit, Bosch Rexroth recommends the following procedure after the running-in phase:

- ▶ After the running-in phase, have a hydraulic fluid sample analyzed for the required cleanliness level.
- ▶ Change the hydraulic fluid if the required cleanliness level is not reached.  
If a laboratory test is not carried out after the running-in phase, it is recommended to change the hydraulic fluid.

## 8.3 Recommissioning after standstill

Depending on the installation conditions and ambient conditions, changes may occur in the hydraulic system which make recommissioning necessary.

The following criteria may make recommissioning necessary:

- Air and/or water in the hydraulic system
  - Old hydraulic fluid
  - Other contamination
- 
- ▶ Before recommissioning, proceed as described in chapter 8.1 "Initial commissioning" on page 45.



## 9 Operation

This product is a component which requires no settings or changes during operation. For this reason, this chapter of the manual does not contain any information on adjustment options. Use the product only within the performance range specified in the technical data.

The machine/system manufacturer is responsible for proper project planning of the hydraulic system and its control.

## 10 Maintenance and repair

### NOTICE

#### Overdue inspection and maintenance work!

Property damage!

- ▶ Perform the specified inspection and maintenance work at the intervals described in this manual.

### 10.1 Cleaning and care

### NOTICE

#### Damage to seals when cleaning

The jet of a high-pressure cleaner may damage the seals and electrical system of the external gear unit.

- ▶ Do not point a high-pressure cleaner at sensitive components, e.g. shaft seal, electrical connections and components.

For cleaning and care of the external gear unit, observe the following:

- ▶ Check whether all seals and fittings on the connections are securely seated to ensure that no moisture can penetrate into the external gear unit during cleaning.
- ▶ Use only water and, if necessary, a mild cleaning agent to clean the external gear unit. Never use solvents or aggressive cleaning agents.
- ▶ Remove major external contamination and keep clean sensitive and important components, such as solenoids, valves, indicators and sensors.

### 10.2 Inspection

In order to enable long and reliable operation of the external gear unit, Bosch Rexroth recommends testing the hydraulic system and external gear unit on a regular basis, and documenting and archiving the following operating conditions:

- Operating temperature given a comparable load condition
- Level of hydraulic fluid
- Quality of hydraulic fluid

The external gear unit itself must be regularly checked for:

- Leakage:  
Early detection of hydraulic fluid loss can help to find errors on the machine or system and to rectify them. For this reason, Bosch Rexroth recommends that the external gear unit and machine/system always be kept in a clean condition.
- Unusual noise development:  
Unusual noise development can have different causes. The chapter 14 "Troubleshooting" on page 55 will help you find possible causes.

- Loosened fastening elements (based on information provided by the machine manufacturer):

All fastening elements have to be checked when the system is switched off, depressurized and cooled down.

By documenting the operating conditions consistently (such as e.g. increasing operating temperatures) you can quickly recognize wear and take the necessary countermeasures.



The external gear unit must only be operated according to the specifications in the offer drawing.

If the external gear unit leaves the permissible operating parameters, stop the system and take corrective action.

### 10.3 Maintenance

External gear units are maintenance-free. The service life of the external gear unit is heavily dependent on the quality of the hydraulic fluid.

The service life of the hydraulic fluid is heavily dependent on the machine or system.

The machine or system manufacturer is thus responsible for determining the maintenance intervals.

### 10.4 Repair

Bosch Rexroth offers a comprehensive range of services for the repair of Rexroth external gear units.

Repairs on the external gear unit and its assembled parts may only be performed by service centers certified by Bosch Rexroth.

- ▶ Use exclusively original spare parts from Rexroth to repair the Rexroth external gear units, otherwise the functional reliability of the external gear unit cannot be assured and you lose your entitlement under warranty.

In the event of questions regarding repair, contact your responsible Bosch Rexroth Service or the service department of the manufacturer's plant for the external gear unit, see chapter 10.5 "Spare parts" on page 51.

### 10.5 Spare parts

#### CAUTION

##### **Use of unsuitable spare parts!**

Spare parts that do not meet the technical requirements specified by Bosch Rexroth can cause injury and property damage!

- ▶ Use exclusively original spare parts from Rexroth to repair the Rexroth external gear units, otherwise the functional reliability of the external gear unit cannot be assured and the warranty is void.

The spare parts lists for external gear units are order-specific. When ordering spare parts, quote the material and serial number of the external gear unit as well as the material numbers of the spare parts.

Address all questions regarding spare parts to your responsible Bosch Rexroth Service partner or the service department of the manufacturer's plant for the external gear unit.

Details for the manufacturer's plant can be found on the name plate of the external gear unit.

Bosch Rexroth AG  
Robert-Bosch-Str. 2  
71701 Schwieberdingen, Germany  
Tel. +49 0711 811-0

Bosch Rexroth AG  
Dieselstraße 10  
90441 Nuremberg, Germany  
Tel. +49 911 665-0

Spare parts can be found online at [www.boschrexroth.com/eshop](http://www.boschrexroth.com/eshop)

For general inquiries, please contact your local contact person.

You can find their contact information at

[www.boschrexroth.com/addresses](http://www.boschrexroth.com/addresses)

# 11 Removal and replacement

## 11.1 Required tools

Removal can be performed using standard tools. No special tools are necessary.

## 11.2 Preparing for removal

1. Decommission the relevant machine/system part as described in the instruction manual for the machine or system.
  - Relieve pressure in the hydraulic system according to the instructions of the machine or system manufacturer.
  - Make sure that the relevant machine/system part is depressurized and de-energized.
2. Secure the relevant machine/system part against reactivation.

## 11.3 Performing the removal

Proceed as follows to remove the external gear unit:

1. Make sure you have the appropriate tools and wear personal protective equipment.
2. Allow the external gear unit to cool down until it can be removed without danger.
3. For below-reservoir installation, before removing the external gear unit, seal the connection to the reservoir and/or drain the reservoir.
4. Place a collecting pan under the external gear unit to collect any hydraulic fluid that may leak.
5. Using a suitable tool, disconnect the external gear unit from the pipelines in such a way that any escaping hydraulic fluid can be captured by the provided collecting pan.
6. Completely drain the external gear unit.
7. Plug all openings.

## 11.4 Preparing the components for storage or further use

- ▶ Proceed as described in chapter 6.2 "Storing the external gear unit" on page 29.

## 12 Disposal

Careless disposal of the external gear unit, the hydraulic fluid and the packaging material can result in environmental pollution.

Observe the following points when disposing of the external gear unit:

- 1.** Completely drain the external gear unit.
- 2.** Dispose of the external gear unit and packaging material in accordance with the national regulations in your country.
- 3.** Dispose of the hydraulic fluid in accordance with the regulations of your country. Also observe the applicable safety data sheet for the hydraulic fluid.
- 4.** Disassemble the external gear unit into its individual parts and properly recycle these parts.
- 5.** For example, separate the parts into:
  - Castings
  - Steel
  - Aluminum
  - Non-ferrous metal
  - Electronic waste
  - Plastic
  - Seals

## 13 Extension and conversion

Do not modify the external gear unit or its assembled parts.



The warranty from Bosch Rexroth only applies to the configuration as delivered. The warranty will be voided if the unit is modified or extended.

## 14 Troubleshooting

The following table may assist you in troubleshooting. The table does not claim to be exhaustive.

Issues may occur in practice that are not listed here.

Only authorized personnel may perform troubleshooting inside a safety area designated by the machine manufacturer.

The typical feature and faults are the columns of the table, the potentially affected parts as they may arise on the external gear unit and machine or system form the rows. The individual table cells describe the causes for the faults (column) for the part (row).

### 14.1 How to proceed for troubleshooting

- ▶ Troubleshoot with reduced operating parameters when possible.
- ▶ Use a systematic and targeted approach, even when pressed for time. Random, indiscriminate removal and changing of settings could make it impossible to determine the original cause of the fault.
- ▶ First get a general idea of how your product works in conjunction with the entire system.
- ▶ Try to find out whether or not the product was working properly in conjunction with the entire system before the fault occurred.
- ▶ Try to determine any changes to the entire system in which the product is installed:
  - Have there been any changes to the application conditions or operating range of the product?
  - Has maintenance work recently been carried out? Is there an inspection or maintenance log?
  - Have any changes (e.g. upgrades) or repairs been made to the overall system (machine/system, electrics, control) or to the product? If yes: What changes?
  - Has the hydraulic fluid been changed?
  - Has the product or machine been used as intended?
  - How does the malfunction appear?
- ▶ Try to get a clear idea of the cause of the fault. Directly ask the (machine) operator.
- ▶ Document the work carried out.
- ▶ If the fault cannot be corrected, please refer to one of the contact addresses at: [www.boschrexroth.com/addresses](http://www.boschrexroth.com/addresses).

## 14.2 Malfunction table

**Table 13: External gear unit malfunction table**

Malfunction	Possible cause	Remedy
Unusual noises	Insufficient air bleeding of the hydraulic system	Fill the external gear unit, suction line for the hydraulic pump and the reservoir
		Completely air bleed the external gear unit and hydraulic system
		Check correct installation position
	Insufficient suction conditions, e.g. insufficient dimensioning of the suction line, viscosity of the hydraulic fluid too high, suction height too high, suction pressure too low, foreign particles in the suction line, impermissible filter in the suction line	Machine/system manufacturer: Check the system, e.g. optimize inlet conditions, use suitable hydraulic fluid
		Fill the suction line with hydraulic fluid
		Remove foreign particles from the suction line
	Drive speed too high	Machine/system manufacturer: Reduce drive speed
	Output speed too high	Machine/system manufacturer: Reduce drive speed
	Wrong direction of rotation	Machine/system manufacturer: Check correct direction of rotation, see chapter 7.4.1 "Preparation" on page 34
	Improper mounting of the external gear unit	Check the mounting of the external gear unit according to the specifications of the machine/system manufacturer (observe tightening torques)
Improper mounting of assembled parts, hydraulic lines or improper installation of the coupling	Fasten assembled parts according to the parameters provided by the coupling fitting manufacturer	
Mechanical damage to the external gear unit (e.g. bearing damage)		Replacing external gear unit
		Contact Bosch Rexroth Service
Increased, unusual vibration	Bearings worn	Contact Bosch Rexroth Service
No or insufficient flow	Insufficient air bleeding of the hydraulic system	Fill the external gear unit, suction line for the hydraulic pump and the reservoir
		Completely air bleed the external gear unit and hydraulic system
	Faulty mechanical drive (e.g. defective coupling)	Contact machine/system manufacturer
	Drive speed too low	Contact machine/system manufacturer
	Insufficient suction conditions, e.g. insufficient dimensioning of the suction line, viscosity of the hydraulic fluid too high, suction height too high, suction pressure too low, foreign particles in the suction line, impermissible filter in the suction line	Machine/system manufacturer: Check the system, e.g. optimize inlet conditions, use suitable hydraulic fluid
		Fill the suction line with hydraulic fluid
		Remove foreign particles from the suction line
	Hydraulic fluid not in optimal viscosity range	Machine/system manufacturer: Check temperature range and use suitable hydraulic fluid
	Wear or mechanical damage to the external gear unit	
Contact Bosch Rexroth Service		



**Table 13: External gear unit malfunction table**

<b>Malfunction</b>	<b>Possible cause</b>	<b>Remedy</b>
No or insufficient pressure	Insufficient air bleeding of the hydraulic system	Fill the external gear unit, suction line for the hydraulic pump and the reservoir
		Completely air bleed the external gear unit and hydraulic system
		Check correct installation position
	Faulty mechanical drive (e.g. defective coupling)	Contact machine/system manufacturer
	Faulty mechanical output drive (e.g. defective coupling)	Contact machine/system manufacturer
	Drive power too low	Contact machine/system manufacturer
	Drive power too low	Contact machine/system manufacturer
	Insufficient suction conditions, e.g. insufficient dimensioning of the suction line, viscosity of the hydraulic fluid too high, suction height too high, suction pressure too low, foreign particles in the suction line, impermissible filter in the suction line	Machine/system manufacturer: Check the system, e.g. optimize inlet conditions, use suitable hydraulic fluid
		Fill the suction line with hydraulic fluid
	Hydraulic fluid not in optimal viscosity range	Remove foreign particles from the suction line
		Machine/system manufacturer: Check temperature range and use suitable hydraulic fluid
	Wear or mechanical damage to the external gear unit	Replacing external gear unit
		Contact Bosch Rexroth Service
Drive unit defective (e.g. hydraulic pump)	Contact machine/system manufacturer	
Output unit defective (e.g. hydraulic motor or cylinder)	Contact machine/system manufacturer	
Rotational speed or torque cannot be reached	Insufficient flow in hydraulic pump	Check function of the hydraulic pump
	Hydraulic fluid not in optimal viscosity range	Machine/system manufacturer: Check temperature range and use suitable hydraulic fluid
	Wear or mechanical damage to the external gear unit	Replacing external gear unit
		Contact Bosch Rexroth Service
	Wear or mechanical damage to the hydraulic pump	Replace hydraulic pump
		Contact Bosch Rexroth Service
Wrong direction of rotation	Check function of the hydraulic pump	
	Machine/system manufacturer: Check correct direction of rotation, see chapter 7.4.1 "Preparation" on page 34	
Excessively high temperature of hydraulic fluid and housing	Excessive inlet temperature at the external gear unit	Machine/system manufacturer: Inspect system, e.g. malfunction in the cooler, insufficient hydraulic fluid in the reservoir
	Output speed too high	Contact machine/system manufacturer
	Wear on the external gear unit	Replace external gear unit, contact Bosch Rexroth Service

**Table 13: External gear unit malfunction table**

Malfunction	Possible cause	Remedy
External leakage at the external gear unit or oil leakage at an adjacent component during commissioning or operation	Leakage on the external gear unit	If the hydraulic fluid continues to leak at the external gear unit, contact your responsible Bosch Rexroth service partner.
	A temperature increase can cause a one-time oil leak between the covers of multiple pumps (this does not result in a functional restriction)	Clean the external gear pump. Never use solvents or aggressive cleaning agents.
	Leakage of adjacent components	Check if hydraulic fluid is leaking at adjacent components and correct the cause of the fault.

## 15 Technical data

The permissible technical data of the external gear unit can be found in the product-specific data sheet, see Table 1, page 7.

The data sheets can be found in the online product catalog at [www.boschrexroth.com/external-gear-pumps](http://www.boschrexroth.com/external-gear-pumps)



[www.boschrexroth.com/external-gear-motors](http://www.boschrexroth.com/external-gear-motors)



Order-related technical data for your external gear unit can be found in the order confirmation.

## 16 Alphabetical index

<b>A</b>		<b>I</b>	
Abbreviations.....	10	Identification .....	23
Axial field seal .....	22	Inspection .....	50
<b>B</b>		Installation .....	32
Bearing bushing.....	22	Installation conditions.....	33
Below-reservoir installation.....	34	Installation position	
<b>C</b>		Below-reservoir installation .....	34
Care .....	50	Intended use .....	11
Centering pin.....	22	<b>L</b>	
Cleaning .....	50	Layout .....	21
Commissioning.....	44	Lifting devices .....	28
Initial .....	45	Lifting strap.....	29
Conversion .....	54	<b>M</b>	
Cooler .....	26	Maintenance.....	50, 51
Corrosion protection .....	30	Malfunction table .....	56
Corrosion protection film .....	30	<b>N</b>	
<b>D</b>		Name plate .....	23
Designations.....	9	<b>O</b>	
Dimensions.....	28	Operation .....	49
Direction of rotation .....	34	<b>P</b>	
Disposal .....	54	Performance description .....	21
Distributor plate .....	22	Piping.....	24, 26
Drive shaft.....	22	Pressure side.....	22
<b>E</b>		Product description.....	21
External gear motors .....	22	Property damage .....	17
External gear pumps.....	22	Pump housing.....	22
<b>F</b>		<b>Q</b>	
Filling .....	46	Qualification .....	12
Filter.....	26	<b>R</b>	
Front cover .....	22	Rear cover .....	22
Functional test .....	47	Recommissioning	
<b>G</b>		After standstill .....	48
Gear wheel.....	22	Removal.....	53
<b>H</b>		Performing.....	53
Hose lines .....	26	Preparing .....	53
Housing seal ring.....	22	Repair.....	55
Hydraulic fluids .....	11	Replacement .....	53
		Required documentation .....	7
		Reservoir .....	24
		Retaining plate .....	22
		Running-in phase.....	48

**S**

Safety instructions .....	11
General .....	13
Product-specific .....	14
Signal word .....	9
Scope of delivery .....	20
Shaft seal .....	22
Slide bearings .....	22
Snap ring .....	22
Storage .....	28, 29
Storage time .....	30
Stroking piston .....	22
Suction line .....	25
Suction pressure .....	33
Supporting element .....	22
Symbols .....	9

**T**

Technical data .....	59
Temperatures .....	23
Threaded plugs .....	38, 40
Tools .....	53
Torx screws .....	22
Transport .....	28
By hand .....	28
with lifting strap .....	29
Transporting .....	28
Troubleshooting .....	55

**U**

Unpacking .....	32
-----------------	----

**W**

Warranty .....	19, 54
Weight .....	28

**Bosch Rexroth AG**

Robert-Bosch-Straße 2  
71701 Schwieberdingen,  
Germany  
brm-az.info@boschrexroth.de  
www.boschrexroth.com

**Bosch Rexroth AG**

Dieselstraße 10  
90441 Nuremberg, Germany  
Tel. +49 911 665-0

**Your local contact person can be found at:**

[www.boschrexroth.com/addresses](http://www.boschrexroth.com/addresses)