

# Lift inspection stations

Harmony<sup>®</sup> XALF

Catalog

January 2019



# Quick access to Product information

## Select your Catalogue, your Training

### Digi-Cat

The complete digital catalogue for industrial automation



Makes your choice easy every day, everywhere!



With just 3 clicks, you can reach the 7,000 pages of the Industrial Automation & Control catalogue, in both English and French.

- Digi-Cat is available on a USB key (for PC). To get your Digi-Cat, please contact your local center
- Download Digi-Cat from this address:

<http://digi-cat.schneider-electric.com/download.html>

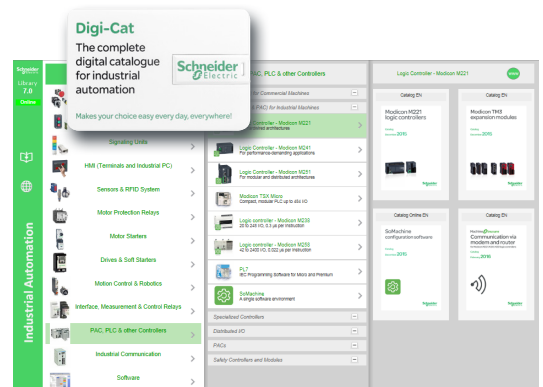

### Find your training

- Find the right training for your needs
- Locate the training center with the selector tool, using this address:

<http://www.schneider-electric.com/b2b/en/services/training/technical-training.jsp>

then click on

Find your training center

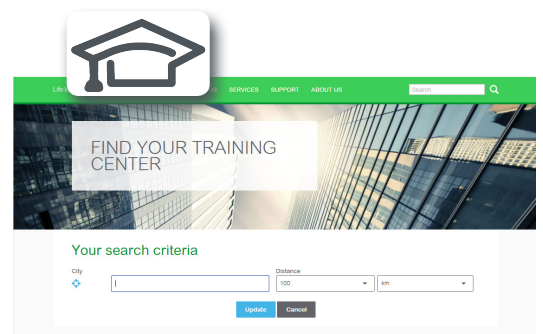

Life Is On



# General contents

## Lift inspection stations Harmony® XALF

<b>Selection guide</b> .....	<b>page 2</b>
■ <b>Presentation, functions</b> .....	<b>page 4</b>
■ <b>Description</b> .....	<b>page 5</b>
■ <b>References</b>	
□ Hoistway boxes .....	<b>page 6</b>
□ Pit switch boxes .....	<b>page 7</b>
□ Top of car boxes.....	<b>page 8</b>
□ Separate components .....	<b>page 9</b>
■ <b>Product reference index</b> .....	<b>page 14</b>

Type of applications	All applications	
Enclosures	Plastic	Glass-reinforced polyester
	Complete stations and separate components for customer assembly	Empty insulated enclosures

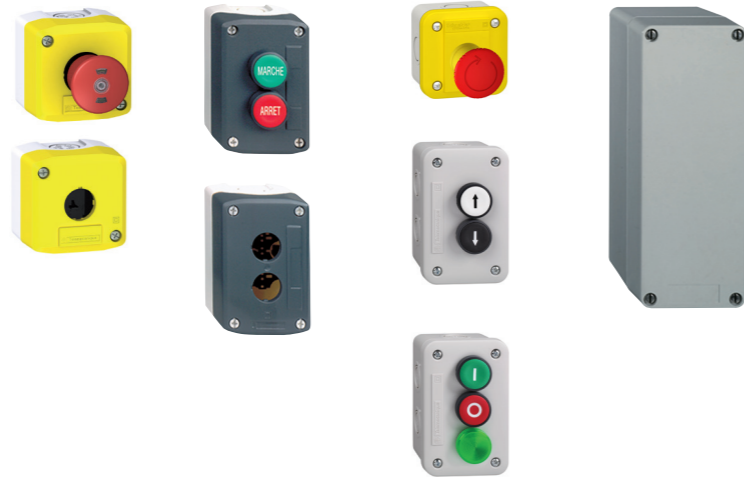

Main feature	Pre-drilled control stations		Pre-drilled or undrilled enclosures
Associated control and signaling units	Harmony XB5 with plastic bezel		Harmony XB7, monolithic, plastic Harmony XB4 with metal bezel Harmony XB5 with plastic bezel
Number of cut-outs for Ø 22 control and signaling units	1, 2, 3, 4 or 5	1, 2 or 3 (complete stations) 1, 2, 3, 4 or 5 (empty enclosures)	1, 2 or 3 1, 2, 4, 8 or 16
Material	Polycarbonate		ABS Glass-reinforced polyester
Color	Yellow lid Light grey base	Dark grey lid Light grey base	Light grey or yellow lid Light grey base Coloured grey throughout
Degree of protection	IP 65 / NEMA Enclosure type 4, 4X and 13		IP 54 IP 65
Function	Emergency Stop or Emergency switching off	Start or Stop Start-Stop with pilot light Motion control	According to equipment fitted: <input type="checkbox"/> Start or Stop <input type="checkbox"/> Start-Stop with pilot light <input type="checkbox"/> Motion control <input type="checkbox"/> Emergency stop
Cable entries	Knock-outs (CM12)		Knock-outs (ISO 20) Undrilled
Type references	XALK	XALD	XALE XAPA

All applications		Specific applications		
Metal	Metal front plate, insulated protective rear cover	Plastic		Metal
Empty enclosures	Empty, flush mounting enclosures: front plate + rear cover	Control stations for severe environments	Lift inspection stations	Key operated control stations



Pre-drilled enclosures	Pre-drilled or undrilled enclosures	Pre-drilled front plates & rear covers	Pre-drilled empty control stations	Pre-drilled empty enclosures or fitted stations	Fitted stations
Harmony XB4 with metal bezel Harmony XB5 with plastic bezel			Harmony XB5 with plastic bezel	Harmony XB5 or XB7 with plastic bezel	With key lock bezel
8, 16, 24, 30 or 40	1, 2, 3, 4, 6, 8 or 12	1, 2, 3, 4 or 5	1, 2, 3, 4 or 5	1, 2, 3, 4, 5 or 6 with or without power socket	-
Aluminium alloy or sheet steel	Zinc or aluminium alloy	Front plate: brushed aluminium Rear cover: polystyrene	Mineral reinforced polyamide	Polycarbonate	Zinc alloy
Blue lid and base	<b>XAPM:</b> Blue lid Blue base <b>XAPJ:</b> Yellow lid Blue base	Unpainted aluminium	Black lid Black base	Yellow lid Light grey base	Grey
IP 54	IP 65		IP 66 IP 69K	IP 44 (with power socket) IP 55 or IP 66 depending on model	IP 54
According to equipment fitted: <input type="checkbox"/> Start or Stop <input type="checkbox"/> Start-Stop with pilot light <input type="checkbox"/> Motion control <input type="checkbox"/> Emergency stop					Start-Stop
<input type="checkbox"/> Tapped entries for cable-glands <input type="checkbox"/> or undrilled	Tapped entries for cable-glands	Knock-outs (with protective rear cover)	Two ISO 20 open entries	<input type="checkbox"/> Knock-outs (CM12) <input type="checkbox"/> or undrilled	Tapped for cable-glands
XB2SL	XAPM, XAPJ	XAPE	XALG	<b>XALF</b>	XAPS

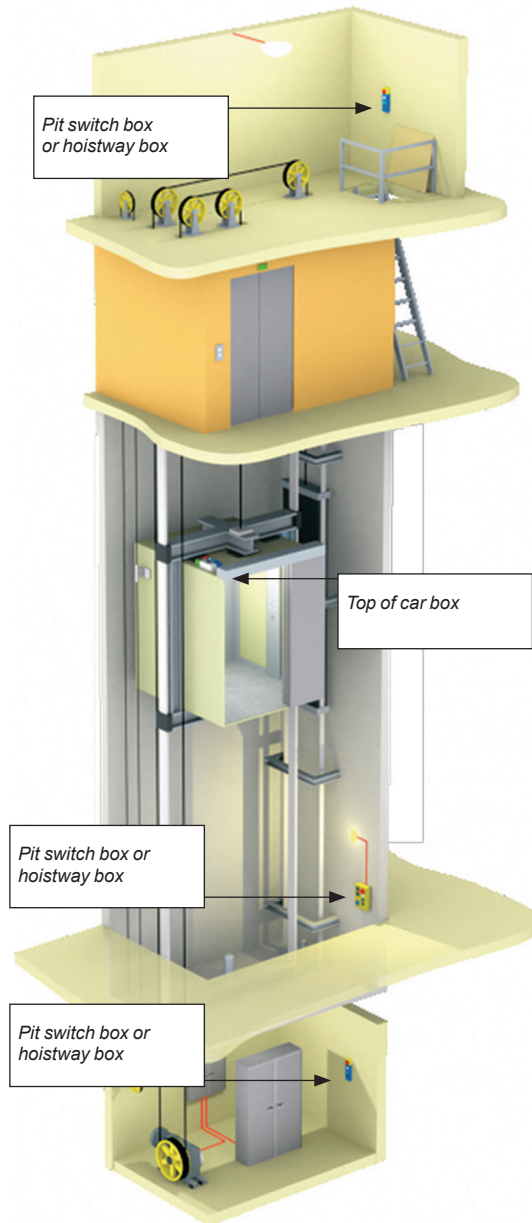

#### Presentation

The Harmony® XALF lift inspection stations are designed for lift maintenance applications.

Three types of station are available:

- Top of car boxes
  - Pit switch boxes
  - Hoistway boxes
- These boxes make it possible to control movement of the lift.
  - Used in conjunction with the other operating components, they facilitate inspection and repair work.
  - They are installed outside the lift car.
  - Inspection stations help prevent the risk of uncontrolled movement of the lift while inspections are being carried out.
  - Supplied complete, these lift inspection stations are equipped with CÉ certified Ø 22 control and signaling units from the Harmony XB5 and XB7 ranges.
  - Stations can also be configured by the user: empty enclosures that can be equipped to meet custom requirements are available from the catalog.

#### Environment

- Degree of protection (conforming to standard EN/IEC 60529):
  - IP 54
  - IP 44 with power socket (see page 11)
- Conformity to standards:
  - EN 81-20, EN/IEC 60947-1, EN/IEC 60947-5-1, EN/IEC 60947-5-4, and EN/IEC 60947-5-5
  - EN/ISO 13850 (if equipped with "trigger action" Emergency Stop pushbuttons with pilot light and mechanical state indicator)
- Product certification: CÉ

#### Mounting and fixing

- Hoistway box and pit switch box: Knock-outs for no. 13 (CM12, Pg13.5) cable glands and tapped ISO 20
- Top of car box: cut-outs required

#### Functions

Function	Equipment
<b>Control and signaling</b>	<ul style="list-style-type: none"> <li>■ Flush pushbuttons, unmarked or with marking (1)</li> <li>■ Selector switches with standard handle or key switches</li> <li>■ Pilot lights with integral LED and "true colors"</li> <li>■ Illuminated pushbuttons</li> </ul>
<b>Emergency Stop (EN/ISO 13850)</b>	<ul style="list-style-type: none"> <li>■ Mushroom head, trigger action and latching, Emergency Stop pushbutton with pilot light and mechanical state indicator:                             <ul style="list-style-type: none"> <li>□ White LED, on front panel</li> <li>□ 360° mechanical indication by green ring and by 2 windows with green/red indication on front panel</li> </ul> </li> </ul>
<b>Power socket</b>	<ul style="list-style-type: none"> <li>■ Extensive range of power sockets to meet the specific needs of each country. Degree of protection IP 44.</li> </ul>

(1) Double injection-molded marking.



# Control stations and enclosures

## Lift inspection stations Harmony XALF

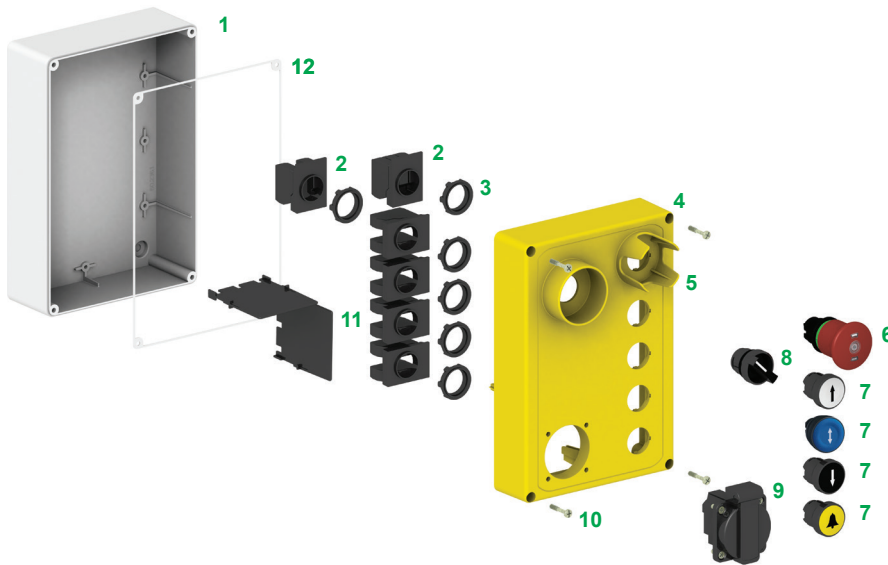

### Description

#### Top of car boxes

- 1 Enclosure base, gray
- 2 Contact block
- 3 Nuts
- 4 Enclosure lid, yellow
- 5 Guard
- 6 Red, mushroom head, latching Emergency Stop pushbutton with pilot light (white) and mechanical state indicator (green/red)
- 7 Flush pushbuttons, with marking: ⬆, ⬇, ⬆, ⬇, ⚠
- 8 Selector switch with standard handle
- 9 230 V power socket
- 10 Stainless steel screws
- 11 Partition plates
- 12 Gasket

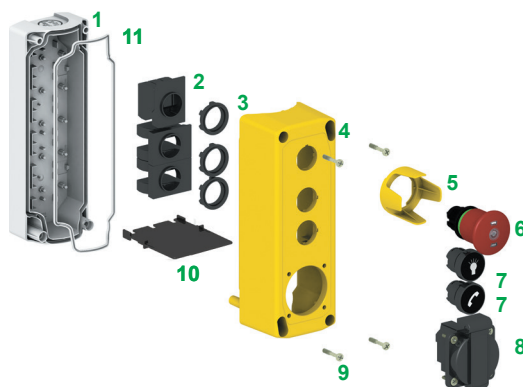

#### Pit switch boxes

- 1 Enclosure base, gray
- 2 Contact block
- 3 Nuts
- 4 Enclosure lid, yellow
- 5 Guard
- 6 Red, mushroom head, latching Emergency Stop pushbutton with pilot light (white) and mechanical state indicator (green/red)
- 7 Flush pushbuttons, with marking ⬆, ⬇, ⬆, ⬇, ⚠
- 8 230 V power socket
- 9 Stainless steel screws
- 10 Partition plate
- 11 Gasket

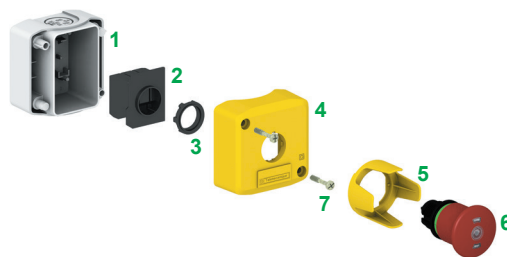

#### Hoistway boxes

























- 1 Enclosure base, gray
- 2 Contact block
- 3 Nut
- 4 Enclosure lid, yellow
- 5 Guard
- 6 Mushroom head for latching Emergency Stop pushbutton with pilot light (white) and mechanical state indicator (green/red)
- 7 Stainless steel screws

# Control stations and enclosures

Lift inspection stations

Harmony XALF

Complete stations, empty enclosures

Hoistway boxes (gray base and yellow lid)						
Complete boxes						
Description	Type of push	Type of contact		Shape of head	Reference	Weight kg/lb
		NO	NC			
 105765 XALFKT64451 1 red, mushroom head Emergency Stop pushbutton, with guard	Latching, with mechanical state indicator (green/red)	1	1		XALFKT64451	0.175/0.386
		–	1		XALFKT64421	0.165/0.364
		–	2		XALFKT64441	0.175/0.386
 105766 XALFKT6445 1 red, mushroom head Emergency Stop pushbutton	Latching, with pilot light (white) and mechanical state indicator (green/red)	1	1		XALFKT6445●11 (1)	0.185/0.408
		–	1		XALFKT6445	0.165/0.364
		–	2		XALFKT6442	0.155/0.342
 105769 XALFKT6444 1 red, mushroom head Emergency Stop pushbutton	Latching, with mechanical state indicator (green/red)	–	2		XALFKT6444	0.165/0.364
		1	1		XALFKT6445●1 (1)	0.175/0.386
		1	1		XALFKT6445	0.165/0.364
 105768 XALFKA2521 1 spring return pushbutton	Flush black	1	–		XALFKA2521	0.130/0.287
		1	1		XALFKA2525	0.140/0.309
		2	–		XALFKA2523	0.140/0.309
 105770 XALFKA5511 1 spring return pushbutton	Flush yellow	1	–		XALFKA5511	0.130/0.287
		1	1		XALFKA5515	0.140/0.309
		2	–		XALFKA5513	0.140/0.309
 105771 XALFKA2531 1 spring return pushbutton	Flush black	1	–		XALFKA2531	0.130/0.287
		1	1		XALFKA2535	0.140/0.309
		2	–		XALFKA2533	0.140/0.309

Empty enclosure for configuration by the user			
Number of Ø 22 mm cut-outs	Dimensions (2) w x h x d mm/in.	Reference	Weight kg/lb
1	68 X 68 X 54 / 2.68 X 2.68 X 2.13	XALFK01	0.110/0.243

(1) Replace the ● in the reference with **B** for 24 V ~, with **G** for 110 ...120 V ~, or with **M** for 230...240 V ~.  
 (2) Please visit our website [www.schneider-electric.com](http://www.schneider-electric.com) for more precise information about component dimensions.

**Other versions** Please contact our Customer Care Center.

#### Pit switch boxes (gray base and yellow lid)

##### Complete boxes

Description	Type of push	Type of contact		Shape of head	Reference	Weight kg/lb
		NO	NC			



XALFK2001E

1 red, mushroom head Emergency Stop pushbutton, with guard	Latching, with mechanical state indicator (green/red)	1	1		XALFK2001E	0.500/1.102
1 spring return pushbutton	1 flush black	1	–			
1 power socket (IEC blue) (1)						



XALFK3001E

1 red, mushroom head Emergency Stop pushbutton, with guard	Latching, with mechanical state indicator (green/red)	1	1		XALFK3001E	0.550/1.212
2 spring return pushbuttons	1 flush black 1 flush black	1 1	– –	 		
1 power socket (IEC blue) (1)						

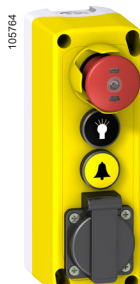

XALFK3011E

1 red, mushroom head Emergency Stop pushbutton, with guard	Latching, with pilot light (white 24 V ~ / –) and mechanical state indicator (green/red)	1	1		XALFK3011E	0.550/1.212
2 spring return pushbuttons	1 flush black 1 flush yellow	1 1	– –	 		
1 power socket (IEC blue) (1)						

##### Empty enclosures for configuration by the user

Number of Ø 22 mm cut-outs	Number of Ø 45 mm cut-outs for power socket	Dimensions (2) w x h x d mm/in.	Reference	Weight kg/lb
3	–	68 X 196 X 147/ 2.68 X 7.72 X 5.79	XALFK03	0.290/0.639
4	–	68 X 196 X 147/ 2.68 X 7.72 X 5.79	XALFK04	0.290/0.639
2	1	68 X 196 X 147/ 2.68 X 7.72 X 5.79	XALFK021	0.290/0.639
3	1	68 X 196 X 147/ 2.68 X 7.72 X 5.79	XALFK031	0.290/0.639

(1) IEC blue power socket type XALFZE3; for other types of power socket, see page 13.

(2) Please visit our website [www.schneider-electric.com](http://www.schneider-electric.com) for more precise information about component dimensions.

Other versions

Please contact our Customer Care Center.



XALFK04



XALFK031



# Control stations and enclosures

## Lift inspection stations

### Harmony XALF

#### Complete stations, empty enclosures

#### Top of car boxes (gray base and yellow lid)

##### Complete boxes

Description	Type of operator	Type of contact		Shape of head	Reference	Weight kg/lb
		NO	NC			
<b>1 red, mushroom head Emergency Stop pushbutton, with guard</b>  <b>4 spring return pushbuttons</b>	Latching, with mechanical state indicator (green/red)	1	1		<b>XALFP6003E</b>	0.810/1.786
	1 flush white	2	–			
	1 flush blue	1	–			
	1 flush black	2	–			
	1 flush yellow	1	–			
<b>1 selector switch, with guard</b>  <b>1 power socket (IEC blue) (1)</b>	Standard black handle, 2-position stay put	3	3			
<b>1 red, mushroom head Emergency Stop pushbutton, with guard</b>  <b>4 spring return pushbuttons</b>	Latching, with pilot light (white 24 V ~/-) and mechanical state indicator (green/red)	1	1		<b>XALFP7005E</b>	0.850/1.873
	1 flush white	2	–			
	1 flush blue	1	–			
	1 flush black	2	–			
	1 flush yellow	1	–			
<b>2 selector switches, with guard</b>  <b>1 power socket (IEC blue) (1)</b>	Standard black handle, 2-position stay put	2	2			
	Standard black handle, 3-position spring return to center	1	1			
<b>1 red, mushroom head Emergency Stop pushbutton, with guard</b>  <b>2 spring return pushbuttons</b>	Latching, with mechanical state indicator (green/red)	1	1		<b>XALFK4001</b>	0.550/1.213
	1 flush white	2	–			
	1 flush black	2	–			
<b>1 selector switch, with guard</b>  <b>1 red, mushroom head Emergency Stop pushbutton, with guard</b>	Standard black handle, 2-position stay put	2	2		<b>XALFK4002</b>	0.495/1.091
	Latching, with mechanical state indicator (green/red)	1	1			
<b>1 spring return pushbuttons</b>  <b>1 spring return pushbuttons</b>  <b>1 selector switch, with guard</b>	1 flush blue	2	–			
	1 double-head	2	–			
	Standard black handle, 2-position stay put	2	2			

##### Empty enclosures for configuration by the user

Number of Ø 22 mm cut-outs	Number of Ø 45 mm cut-outs for power socket	Dimensions (2) w x h x d mm/in.	Reference	Weight kg/lb
6	1	150 X 220 X 172 / 5.91 X 8.66 X 6.77	<b>XALFP0612</b>	0.500/1.102
	0	150 X 220 X 172 / 5.91 X 8.66 X 6.77	<b>XALFP0602</b>	0.500/1.102
7	1	150 X 220 X 172 / 5.91 X 8.66 X 6.77	<b>XALFP0714</b>	0.500/1.102
	0	150 X 220 X 172 / 5.91 X 8.66 X 6.77	<b>XALFP0704</b>	0.500/1.102

(1) IEC blue power socket type XALFZE3; for other types of power socket, see page 13.

(2) Please visit our website [www.schneider-electric.com](http://www.schneider-electric.com) for more precise information about component dimensions.

##### Other versions

Please contact our Customer Care Center.



XALFP6003E



XALFP7005E



XALFK4001



XALFK4002

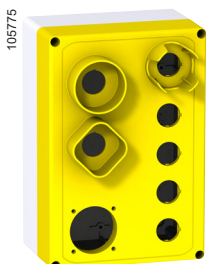

XALFP0714

Heads to combine with bodies:  
see page 12

#### Pushbuttons, switches, and pilot lights for user assembly

##### Heads only

Description	Type of push	Marking		Color of push	Reference	Weight kg/lb
		Symbol	Color			
Heads for spring return pushbuttons	Flush		Black	Yellow	ZB5AA551	0.018/0.040
			Black	White	ZB5AA334	0.018/0.040
			White	Blue	ZB5AA651	0.018/0.040
			White	Black	ZB5AA335	0.018/0.040
			White	Black	ZB5AA252	0.018/0.040
			White	Black	ZB5AA253	0.018/0.040
			Orange		ZB5AA58	0.018/0.040
Flush, illuminated (1)						
Illuminated mushroom head for Emergency Stop trigger action and mechanical latching pushbuttons (2)	Push-pull Ø 40 mm/1.57 in. With pilot light (3) and mechanical state indicator		–	Red	ZB5AT8643M	0.034/0.075



#### Selector switches and key switches for user assembly

##### Heads only

Description	Type of operator	Shape of head	Number and type of positions	Reference	Weight kg/lb
Heads for selector switches	Standard handle, black		2 - stay put	ZB5AD2	0.025/0.055
			3 - spring return to center	ZB5AD5	0.025/0.055
			2 - stay put (5)	ZB5AG2	0.050/0.110
Key switch with key no. 455 (4)					
Heads for illuminated selector switches with standard handle (3)	Standard handle, green		2 - stay put	ZB5AK1233	0.021/0.046



Protected  
**LED**

(1) For insertion of legend.

(2) Conforming to standards EN/IEC 60204-1 and EN/ISO 13850, to Machinery Directive 98/37/EC, and to standard EN/IEC60947-5-5.

(3) For use with bodies comprising a light source with integral LED. For light blocks and body fixing collar, see page 12. Maximum number of contacts attached to the associated body: 2.

(4) Other key numbers available:

- Key no. 421E: add suffix **12** to the reference
- Key no. 458A: add suffix **10** to the reference
- Key no. 520E: add suffix **14** to the reference
- Key no. 3131A: add suffix **20** to the reference

Example: For a switch head with key no. 421E, 2-position stay put with key withdrawal from the left-hand position, the reference becomes: **ZB5AG212**. For specific keys with other numbers, please contact our Customer Care Center.

(5) The symbol indicates key withdrawal position(s).

##### Other versions

Specific markings on boxes  
Other power sockets  
Special cut-outs in enclosures  
Customized products

Please contact our Customer Care Center.

# Control stations and enclosures

Lift inspection stations

Harmony XALF



Separate components: Ø 22 mm control and signaling units with plastic bezel

PF100406



XB7EV08GP

Pilot lights							
With integral LED							
Shape of head	Type of light source (included)	Color of lens	Sold in lots of	Unit reference by supply voltage (1)			Weight kg/lb
				24 V ~/-	120 V ~	230 V ~	
 <b>Integral LED</b>	Integral LED	Green	10	XB7EV03BP	XB7EV03GP	XB7EV03MP	0.020/0.044
		Red	10	XB7EV04BP	XB7EV04GP	XB7EV04MP	0.020/0.044
		Yellow	10	XB7EV05BP	XB7EV05GP	XB7EV05MP	0.020/0.044
		Blue	10	XB7EV06BP	XB7EV06GP	XB7EV06MP	0.020/0.044
		Clear	10	XB7EV07BP	XB7EV07GP	XB7EV07MP	0.020/0.044
		Orange	10	XB7EV08BP	XB7EV08GP	XB7EV08MP	0.020/0.044

Pilot lights with integral LED						
Screw clamp terminal connections (Schneider Electric anti-loosening system)						
Complete units						
Description	Shape of head	Supply voltage V	Color	Reference	Weight kg/lb	
Pilot lights with plain lens   <b>Protected LED</b>		24 ~ (50/60 Hz)	White	<b>XB5AVB1</b> (ZB5AVB1 + ZB5AV013)	0.038/0.084	
			Green	<b>XB5AVB3</b> (ZB5AVB3 + ZB5AV033)	0.038/0.084	
			Red	<b>XB5AVB4</b> (ZB5AVB4 + ZB5AV043)	0.038/0.084	
			Orange	<b>XB5AVB5</b> (ZB5AVB5 + ZB5AV053)	0.038/0.084	
			Blue	<b>XB5AVB6</b> (ZB5AVB6 + ZB5AV063)	0.038/0.084	
			110...120 ~ (50/60 Hz)	White	<b>XB5AVG1</b> (ZB5AVG1 + ZB5AV013)	0.038/0.084
		Green	<b>XB5AVG3</b> (ZB5AVG3 + ZB5AV033)	0.038/0.084		
		Red	<b>XB5AVG4</b> (ZB5AVG4 + ZB5AV043)	0.038/0.084		
		Orange	<b>XB5AVG5</b> (ZB5AVG5 + ZB5AV053)	0.038/0.084		
		Blue	<b>XB5AVG6</b> (ZB5AVG6 + ZB5AV063)	0.038/0.084		
		230...240 ~ (50/60 Hz)	White	<b>XB5AVM1</b> (ZB5AVM1 + ZB5AV013)	0.038/0.084	
		Green	<b>XB5AVM3</b> (ZB5AVM3 + ZB5AV033)	0.038/0.084		
		Red	<b>XB5AVM4</b> (ZB5AVM4 + ZB5AV043)	0.038/0.084		
		Orange	<b>XB5AVM5</b> (ZB5AVM5 + ZB5AV053)	0.038/0.084		
		Blue	<b>XB5AVM6</b> (ZB5AVM6 + ZB5AV063)	0.038/0.084		

(1) For Faston connection version (1 x 6.35 mm and 2 x 2.8 mm), add the number "3" to the end of the reference.  
Example: XB7EV07BP becomes XB7EV07BP3.

101293



XB5AVB1

PF130008



XALFZE2

## Power sockets

Description	For use in	Color	Sold in lots of	Unit reference	Weight kg/lb
230 V power socket, with protective shutter (protection: IP 44)	Germany	Black	1	XALFZE2	0.050/0.110
		Blue	1	XALFZE3	0.050/0.110
	France	Gray	1	XALFZF8	0.050/0.110
	Italy	Blue	1	XALFZT3	0.050/0.110
	United Kingdom	Black	1	XALFZB2	0.050/0.110
	Switzerland	Blue	1	XALFZS3	0.050/0.110

107350



ZB5SZ3

## Accessories

Description	Application	Sold in lots of	Unit reference	Weight kg/lb
Partition plates	For 230 V power socket	1	XALFZ1	0.010/0.022
Nut	Fixing the head of Ø 22 mm/0.86 in. control and signaling units	10	ZB5AZ901	0.002/0.004
Plastic blanking plug, round, black (supplied with nut ZB5AZ901)	Ø 22 mm/0.86 in. cut-outs for circular heads	10	ZB5SZ3	0.009/0.020
Bracket for XB5A pushbuttons or XB7E pilot lights	35 mm/1.38 in. mounting rail (for use in modular enclosure)	1	15151	0.040/0.088

068984



15151

# Control stations and enclosures

Lift inspection stations  
Harmony XALF  
Separate components

## Bodies for Ø 22 mm control and signaling units with screw clamp terminal connections (1)

Description	For use with	Type of contact		Reference	Weight kg/lb
		NO	NC		
Fixing collar + single contact block with screw clamp terminal connections	Heads for ZB5 pushbuttons	1	–	ZB5AZ101	0.021/0.046
		–	1	ZB5AZ102	0.021/0.046
		2	–	ZB5AZ103	0.030/0.066
		–	2	ZB5AZ104	0.030/0.066
		1	1	ZB5AZ105	0.030/0.066



Description	For use with	Supply voltage V	Color of light source	Type of contact		Reference	Weight kg/lb
				NO	NC		
Fixing collar + single contact block with screw clamp terminal connections + light block with integral LED	ZB5AA58	24 ~	Orange	1	–	ZB5AW0B51	0.032/0.071

Protected LED

## Contact blocks with screw clamp terminal connections

Description	For use with	Sold in lots of	Type of contact		Unit reference	Weight kg/lb
			NO	NC		
Standard single contact blocks (2) (3)	Heads for ZB5 pushbuttons	5	1	–	ZBE101	0.011/0.024
		5	–	1	ZBE102	0.011/0.024



## Light blocks with screw clamp terminal connections

Description	For use with	Supply voltage V	Color of light source	Sold in lots of	Unit reference	Weight kg/lb	
							Light blocks with integral LED (to combine with heads for integral LED)
Light blocks with integral LED (to combine with heads for integral LED)	ZB5AA58	48...120 ~	Orange	5	ZBVG5	0.017/0.037	
		230...240 ~	Orange	5	ZBVM5	0.017/0.037	
		ZB5AK1233	24 ~	Green	5	ZBVB3	0.017/0.037
		48...120 ~	Green	5	ZBVG3	0.017/0.037	
		230...240 ~	Green	5	ZBVM3	0.017/0.037	
		ZB5AT8643M	24 ~	White	5	ZBVB1	0.017/0.037
		48...120 ~	White	5	ZBVG1	0.017/0.037	
		230...240 ~	White	5	ZBVM1	0.017/0.037	

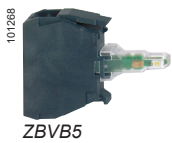

Protected LED

## Accessories

Description	For use with	Supply voltage V	Level of protection	Unit reference	Weight kg/lb
Body/fixing collar Sold in lots of 10	Standard single contact blocks or light blocks with integral LED	–	–	ZB5AZ009	0.006/0.013
LED suppressors for high power applications (≥ 30 VA)	Light blocks with integral LED	120 ~	25...120 VA	ZBZVG	0.010/0.022
		230 ~	30...230 VA	ZBZVM	0.010/0.022



(1) Can be equipped with additional contact blocks.

(2) The contact blocks enable variable composition of body/contact assemblies. Maximum number of rows possible: 3. Either 3 rows of 3 single contacts or 1 row of 3 double contacts + 1 row of 3 single contacts (double contacts occupy 2 rows).

(3) For use with body/fixing collar ZB5AZ009.

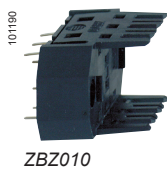
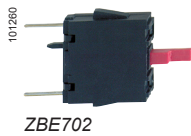
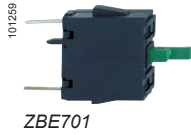

Contact blocks for printed circuit board connection (1)						
Description	Type of contact		For use with	Sold in lots of	Unit reference	Weight kg/lb
	NO	NC				
Standard contact blocks	1	–	Heads for ZB5 pushbuttons	10	ZBE701	0.011/0.024
	–	1	Heads for ZB5 pushbuttons	10	ZBE702	0.011/0.024
Specific contact blocks for low power switching with gold flashed contacts	1	–	Heads for ZB5 pushbuttons	10	ZBE7016	0.011/0.024
	–	1	Heads for ZB5 pushbuttons	10	ZBE7026	0.011/0.024

Light blocks for printed circuit board connection (1)						
Description	Supply voltage V	For use with	Color of LED	Sold in lots of	Unit reference	Weight kg/lb
Integral LED (to combine with heads for integral LED)	24 ~	ZB5AA58	Orange	5	ZBVB57	0.004/0.009
		ZB5AK1233	Green	5	ZBVB37	0.004/0.009
		ZB5AT8643M	White	5	ZBVB17	0.004/0.009

Adapter (socket) for printed circuit board						
For use with	Thickness of printed circuit board mm/in.	Sold in lots of	Unit reference	Weight kg/lb		
Electrical block (contact or light)	1.6 ± 0.20/0.06 ± 0.01	10	ZBZ010	0.008/0.018		
	2.2 ± 0.2/0.09 ± 0.01	10	ZBZ011	0.008/0.018		
	3.2 ± 0.2/0.13 ± 0.01	10	ZBZ012	0.008/0.018		

Accessories specifically for printed circuit board mounting (1)						
Description	For use with	Sold in lots of	Unit reference	Weight kg/lb		
Fixing collar/pillar	Printed circuit board support	10	ZB5AZ079	0.003/0.007		
Fixing screw for printed circuit board	Fixing collar/pillar ZB5AZ079	10	ZBZ006	0.011/0.024		

Accessories for mushroom head pushbuttons						
Description	Color	Unit reference	Weight kg/lb			
Plastic guards for Emergency Stop function	Yellow	ZBZ4005	0.011/0.024			

(1) For details of panel and printed circuit board cut-outs, please visit our website [www.schneider-electric.com](http://www.schneider-electric.com). This is to be used in conjunction with adapter (socket) ZBZ010.



<b>#</b>					
15151	11	XB7EV05GP	10	ZBVB5	12
		XB7EV05MP	10	ZBVB17	13
		XB7EV06BP	10	ZBVB37	13
<b>X</b>		XB7EV06GP	10	ZBVB57	13
XALFK01	6	XB7EV06MP	10	ZBVG1	12
XALFK03	7	XB7EV07BP	10	ZBVG3	12
XALFK04	7	XB7EV07GP	10	ZBVG5	12
XALFK021	7	XB7EV07MP	10	ZBVM1	12
XALFK031	7	XB7EV08BP	10	ZBVM3	12
XALFK2001E	7	XB7EV08GP	10	ZBVM5	12
XALFK3001E	7	XB7EV08MP	10	ZBZ006	13
XALFK3011E	7			ZBZ010	13
XALFK4001	8	<b>Z</b>		ZBZ011	13
XALFK4002	8	ZB5AA58	9	ZBZ012	13
XALFKA2521	6	ZB5AA252	9	ZBZ4005	13
XALFKA2523	6	ZB5AA253	9	ZBZVG	12
XALFKA2525	6	ZB5AA334	9	ZBZVM	12
XALFKA2531	6	ZB5AA335	9		
XALFKA2533	6	ZB5AA551	9		
XALFKA2535	6	ZB5AA651	9		
XALFKA5511	6	ZB5AD2	9		
XALFKA5513	6	ZB5AD5	9		
XALFKA5515	6	ZB5AG2	9		
XALFKT6442	6	ZB5AK1233	9		
XALFKT6444	6	ZB5AT8643M	9		
XALFKT6445	6	ZB5AVB1	10		
XALFKT64421	6	ZB5AVB3	10		
XALFKT64441	6	ZB5AVB4	10		
XALFKT64451	6	ZB5AVB5	10		
XALFP0602	8	ZB5AVB6	10		
XALFP0612	8	ZB5AVG1	10		
XALFP0704	8	ZB5AVG3	10		
XALFP0714	8	ZB5AV033	10		
XALFP6003E	8	ZB5AVG4	10		
XALFP7005E	8	ZB5AV043	10		
XALFZ1	11	ZB5AVG5	10		
XALFZB2	11	ZB5AV063	10		
XALFZE2	11	ZB5AVG6	10		
XALFZE3	11	ZB5AV013	10		
XALFZF8	11	ZB5AVM1	10		
XALFZS3	11	ZB5AVM3	10		
XALFZT3	11	ZB5AVM4	10		
XB5AVB1	10	ZB5AVM5	10		
XB5AVB3	10	ZB5AV053	10		
XB5AVB4	10	ZB5AVM6	10		
XB5AVB5	10	ZB5AW0B51	12		
XB5AVB6	10	ZB5AZ009	12		
XB5AVG1	10	ZB5AZ079	13		
XB5AVG3	10	ZB5AZ101	12		
XB5AVG4	10	ZB5AZ102	12		
XB5AVG5	10	ZB5AZ103	12		
XB5AVG6	10	ZB5AZ104	12		
XB5AVM1	10	ZB5AZ105	12		
XB5AVM3	10	ZB5AZ901	11		
XB5AVM4	10	ZB5SZ3	11		
XB5AVM5	10	ZBE101	12		
XB5AVM6	10	ZBE102	12		
XB7EV03BP	10	ZBE701	13		
XB7EV03GP	10	ZBE702	13		
XB7EV03MP	10	ZBE7016	13		
XB7EV04BP	10	ZBE7026	13		
XB7EV04GP	10	ZBVB1	12		
XB7EV04MP	10	ZBVB3	12		
XB7EV05BP	10				





[www.schneider-electric.com/control](http://www.schneider-electric.com/control)

#### Schneider Electric Industries SAS

Head Office  
35, rue Joseph Monier  
F-92500 Rueil-Malmaison  
France

The information provided in this documentation contains general descriptions and/or technical characteristics of the performance of the products contained herein. This documentation is not intended as a substitute for and is not to be used for determining suitability or reliability of these products for specific user applications. It is the duty of any such user or integrator to perform the appropriate and complete risk analysis, evaluation and testing of the products with respect to the relevant specific application or use thereof. Neither Schneider Electric nor any of its affiliates or subsidiaries shall be responsible or liable for misuse of the information contained herein.

Design: Schneider Electric  
Photos: Schneider Electric