



### Main

Range of product	Modicon Power Supply
Product or component type	Power supply
Power supply type	Regulated switch mode
Variant option	Optimized
Enclosure material	Plastic
Nominal input voltage	100...240 V AC single phase 100...240 V AC 2 phases 140...340 V DC
Rated power in W	75 W
Output voltage	24 V DC
Power supply output current	3.13 A

### Complementary

Input voltage limits	85...264 V AC without temperature derating 120...375 V DC without temperature derating 85...120 V DC with temperature derating
Nominal network frequency	50...60 Hz
Network system compatibility	TN TT IT
Maximum leakage current	1 mA 240 V AC
Input protection type	Integrated fuse (not interchangeable) 5 A External protection (recommended) 20 A Curve C External protection (recommended) 13 A Curve B External protection (recommended) 10 A Curve C
Inrush current	40.0 A at 115 V 80.0 A at 230 V
Power factor	0.55 at 115 V AC 0.45 at 230 V AC
Efficiency	88 % at 230 V AC
Output voltage adjustment	21.6...26.4 V
Power dissipation in W	15 W
Current consumption	< 1.8 A 115 V AC < 1 A 230 V AC < 0.8 A 140 V DC
Turn-on time	< 1.2 s
Holding time	> 20 ms 115 V AC > 40 ms 230 V AC
Startup with capacitive loads	5000 µF
Residual ripple	< 120 mV
Meantime between failure [MTBF]	700000 h at 25 °C, full load conforming to SR 332
Output protection type	Against overload and short-circuits, protection technology: automatic reset Against over temperature, protection technology: manual reset Against overvoltage, protection technology: manual reset
Connections - terminals	Screw connection: 0.5...2.5 mm <sup>2</sup> , (AWG 20...AWG 14) for output Screw connection: 0.75...2.5 mm <sup>2</sup> , (AWG 18...AWG 14) for input
Line and load regulation	< 0.5 % at 0 to 100 % load at 25 °C < 1 % at full voltage range in line at 25 °C
Status LED	1 LED (green) output voltage
Depth	102 mm

Height	123.6 mm
Width	27 mm
Product weight	0.22 kg
Output coupling	Parallel Serial
Mounting support	Top hat type TH35-15 rail conforming to IEC 60715 Top hat type TH35-7.5 rail conforming to IEC 60715 Double-profile DIN rail
Supply	SELV conforming to EN/IEC 60950-1 SELV conforming to EN/IEC 60204-1 SELV conforming to IEC 60364-4-41
Dielectric strength	3000 V AC with input to output
Service life	10 year(s)
Overvoltage category	II

## Environment

Standards	EN 62368-1 EN/IEC 61010-1 EN 61010-2-201 EN/IEC 61204-3 EN 61000-6-1 EN 61000-6-2 EN 61000-6-3 EN 61000-6-4 EN 61000-3-2 EN 61000-3-3 UL 62368-1 UL 61010-1 UL 61010-2-201 CSA C22.2 No 62368-1 CSA C22.2 No 61010-1 CSA C22.2 No 61010-2-201 EN/IEC 62368-1
Product certifications	CE CUL listed CUL recognized RCM CB Scheme EAC KC NEC: class 2
Operating altitude	< 5000 m
Shock resistance	150 m/s <sup>2</sup> for 11 ms
IP degree of protection	IP20
Ambient air temperature for operation	-20...-10 °C with current derating of 1 % per °C mounting position A < 2000 m -10...40 °C without derating mounting position A 115 V AC < 2000 m -10...50 °C without derating mounting position A 230 V AC < 2000 m 40...70 °C with current derating of 1.67 % per °C mounting position A 115 V AC < 2000 m 50...70 °C with current derating of 2.5 % per °C mounting position A 230 V AC < 2000 m
Electrical shock protection class	Class I
Pollution degree	2
Vibration resistance	3 mm (f= 2...9 Hz) conforming to IEC 60068-2-6 10 m/s <sup>2</sup> (f= 9...200 Hz) conforming to IEC 60068-2-6

Electromagnetic immunity	<p>Immunity to electrostatic discharge - test level: 8 kV (contact discharge) conforming to EN/IEC 61000-4-2</p> <p>Immunity to electrostatic discharge - test level: 15 kV (air discharge) conforming to EN/IEC 61000-4-2</p> <p>Immunity to conducted RF disturbances - test level: 15 V/m (80 MHz...2 GHz) conforming to EN/IEC 61000-4-3</p> <p>Immunity to conducted RF disturbances - test level: 5 V/m (2...2.7 GHz) conforming to EN/IEC 61000-4-3</p> <p>Immunity to conducted RF disturbances - test level: 5 V/m (2.7...6 GHz) conforming to EN/IEC 61000-4-3</p> <p>Immunity to fast transients - test level: 4 kV (on input-output) conforming to EN/IEC 61000-4-4</p> <p>Surge immunity test - test level: 4 kV (between power supply and earth) conforming to EN/IEC 61000-4-5</p> <p>Surge immunity test - test level: 3 kV (between phases) conforming to EN/IEC 61000-4-5</p> <p>Immunity to conducted RF disturbances - test level: 15 V (0.15...80 MHz) conforming to EN/IEC 61000-4-6</p> <p>Immunity to magnetic fields - test level: 30 A/m (50...60 Hz) conforming to EN/IEC 61000-4-8</p> <p>Immunity to voltage dips conforming to EN/IEC 61000-4-11</p> <p>Disturbing field emission conforming to EN 55016-2-3</p> <p>Limits for harmonic current emissions conforming to EN 61000-3-2</p> <p>Conforming to EN 55016-1-2</p> <p>Conforming to EN 55016-2-1</p>
Electromagnetic emission	<p>Conducted emissions conforming to EN 61000-6-3</p> <p>Radiated emissions conforming to EN 61000-6-4</p>

## Packing Units

Unit Type of Package 1	PCE
Number of Units in Package 1	1
Package 1 Height	3.7 cm
Package 1 Width	14.0 cm
Package 1 Length	16.0 cm
Package 1 Weight	303.0 g
Unit Type of Package 2	S03
Number of Units in Package 2	22
Package 2 Height	30.0 cm
Package 2 Width	30.0 cm
Package 2 Length	40.0 cm
Package 2 Weight	7.283 kg
Unit Type of Package 3	P12
Number of Units in Package 3	528
Package 3 Height	105.0 cm
Package 3 Width	80.0 cm
Package 3 Length	120.0 cm
Package 3 Weight	192.6 kg

## Offer Sustainability

Sustainable offer status	Green Premium product
REACH Regulation	<a href="#">REACH Declaration</a>
EU RoHS Directive	Pro-active compliance (Product out of EU RoHS legal scope) <a href="#">EU RoHS Declaration</a>
Mercury free	Yes
China RoHS Regulation	<a href="#">China RoHS Declaration</a>
RoHS exemption information	<a href="#">Yes</a>
Environmental Disclosure	<a href="#">Product Environmental Profile</a>
Circularity Profile	<a href="#">End Of Life Information</a>

---

WEEE

The product must be disposed on European Union markets following specific waste collection and never end up in rubbish bins

---

California proposition 65

WARNING: This product can expose you to chemicals including: Lead and lead compounds, which is known to the State of California to cause cancer and birth defects or other reproductive harm. For more information go to [www.P65Warnings.ca.gov](http://www.P65Warnings.ca.gov)

---

---

## Electrical Safety

---

- If the unit is use in a manner not specified by the manufacturer, the protection provided by the equipment may be impaired.
- For means of disconnection a switch or circuit breaker, located near the product, must be included in the installation. A marking as disconnecting device for the product is required.
- The device has an internal fuse. The unit is tested and approved with branch circuit protective device up to 20A. This circuit breaker can be used as disconnecting device.
- The power supply is only suitable for audio, video, information, communication, industrial and control equipment.

---

## Dimensions

---

### Front and Side Views

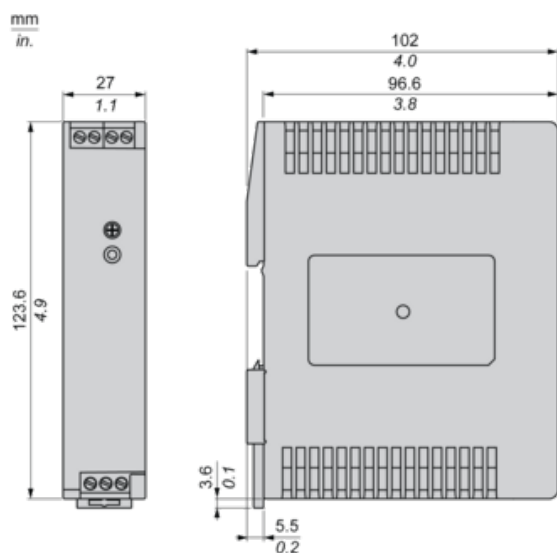

Connections and Schema

Correct Parallel Connection

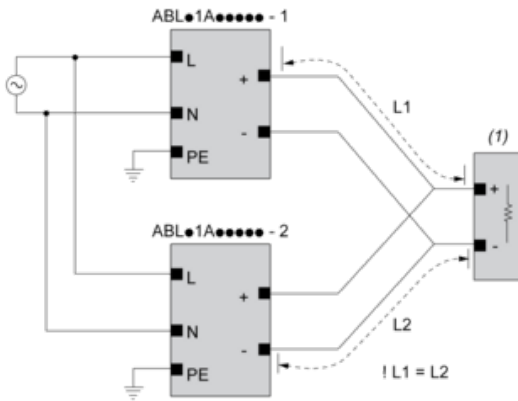

(1) : Load

Incorrect Parallel Connection

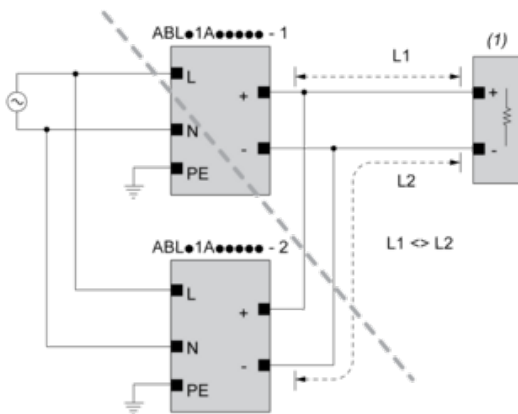

(1) : Load

$ABLx1Axxxxx-1 = ABLx1Axxxxx-2$

max 2 x ABLx1Axxxxx

$L1 = L2$

$\Delta V$  max 25 mV

$L_{Load} < 90\% \cdot 2 \cdot L_{nom}$

Output Voltage Balancing

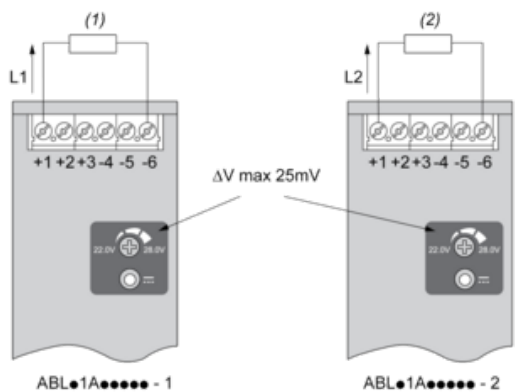

(1) :  $R_{Load1}$

(2) :  $R_{Load2}$

$R_{Load1} = R_{Load2}$

$I_1 = I_2 = \sim I_{nom}$

### Series Connection

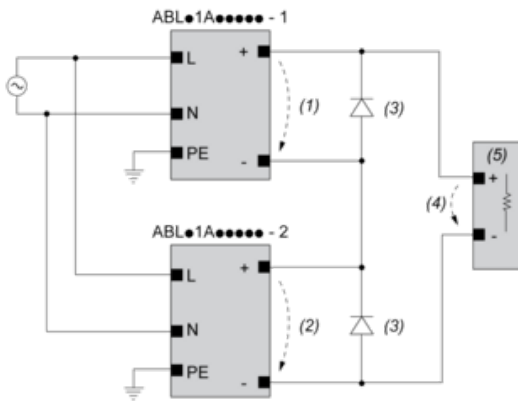

(1) :  $V_{out1}$

(2) :  $V_{out2}$

(3) : 2 x Diode,  $V_{RRM} > 2 \times V_{out1/2}$ ,  $I_F > 2 \times I_{nom1/2}$

(4) :  $V_{Load} = 2 \times V_{out}$

(5) : Load

### Connections and Schema

	(1)		
	<40°C	<50°C	<70°C
ABLS1A24021	50°C	60°C	75°C
ABLS1A24038	50°C	60°C	75°C
ABLS1A12062	50°C	60°C	80°C
ABLS1A24031	50°C	60°C	80°C
ABLS1A12100	60°C	70°C	90°C
ABLS1A24050	60°C	70°C	90°C
ABLS1A48025	60°C	70°C	90°C
ABLS1A24100	60°C	70°C	90°C
ABLS1A24200	95°C	95°C	90°C

(1) : Ambient

Performance Curve

Mounting Position A

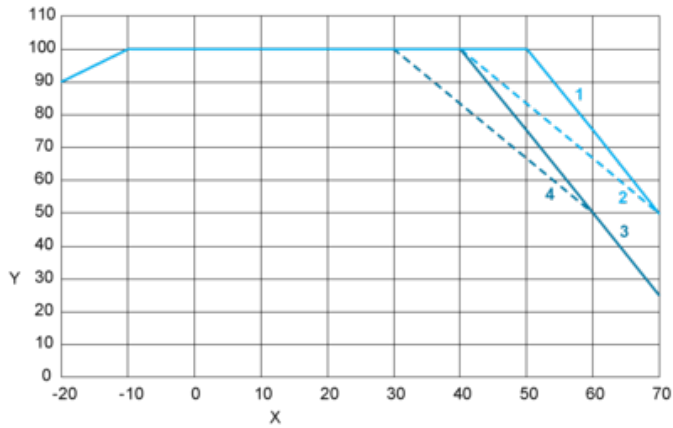

Mounting Position B

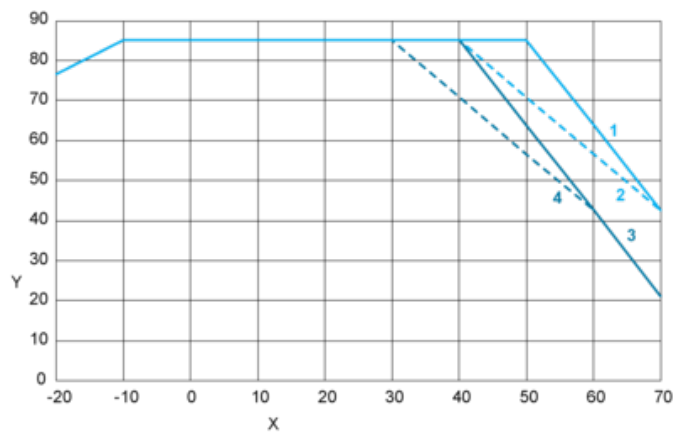

X : Surrounding Air Temperature

Y : Percentage of Max Load (%)

1 : Altitude 2000m, Input voltage = 230 VAC / 325 VDC

2 : Altitude 2000m, 115 VAC / 162 VDC

3 : Altitude 5000m, Input voltage = 230 VAC / 325 VDC

4 : Altitude 5000m, 115 VAC / 162 VDC

DC input voltage

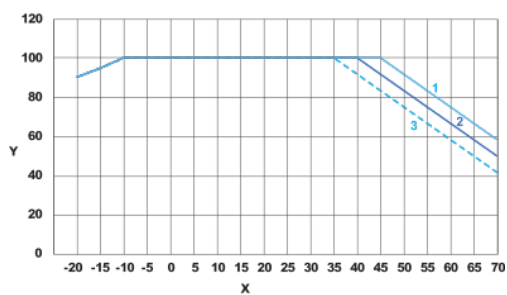

X : Surrounding Air Temperature



Y : Percentage of Maximum Load (%)

1 : 110 VDC

2 : 90 VDC

3 : 85 VDC

Mounting

Mounting Position A

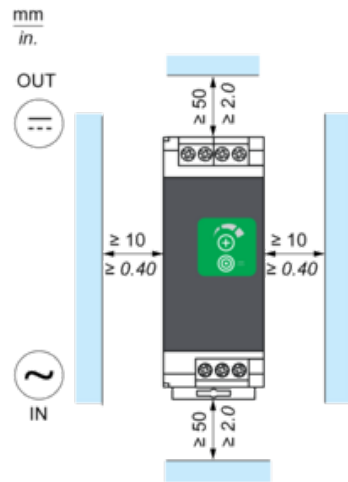

Mounting Position B

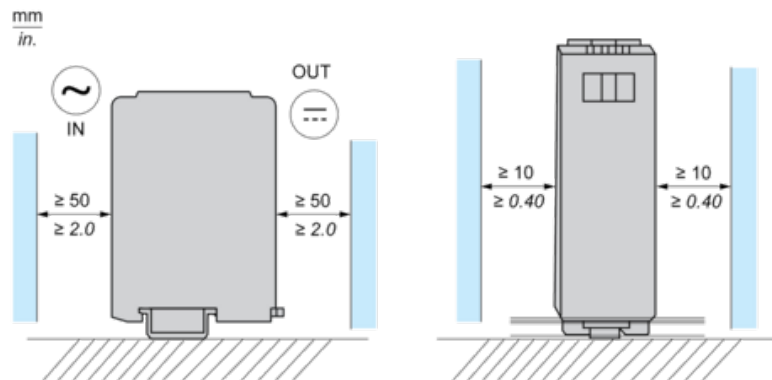

Incorrect Mounting

