



ENGLISH

Datasheet

RS PRO Foot Switch Switch Pushbutton Alternate-Acting

Stock No: 846-6732, 846-6739, 846-6720



Package Contain:

- 1 x Foot Switch
- 2 x Hex Nut
- 1 x Washer
- 1 x Ring

Specification:

SWITCH TYPE:	846-6732, 846-6739, 846-6720	
POLES/THROWS:	SPDT	
SWITCH FUNCTIONS:	ON-ON	
ELECTRICAL & MECHANICAL CHARACTERISTICS	CONTACT RATING:	2A @ 250VAC, 4A @ 125VAC, 2A @ 24VDC, 4A @ 12VDC
	ELECTRICAL LIFE:	20,000 make-and-break cycles at full load
	MECHANICAL LIFE:	Min. 20,000 cycles without load
	CONTACT RESISTANCE:	50m-ohms max. initial @ 2-4VDC, 100mA
	INSULATION RESISTANCE:	Apply 500VDC for 1min±5sec. After which measurement to be made between live parts and dead-metal parts shall result 100M-ohms min.
	DIELECTRICAL STRENGTH:	1,500VAC (50Hz-60Hz) RMS @ sea level shall result no damage to parts arcing or flashover
	OPERATING TEMPERATURE:	-20Celsius degree to +65Celsius degree
	SOLDERING ABILITY:	Per MIL-STD-202F method 208D,max soldering temperature @ 260Celsius degree, flux 5-10sec, duration of solder immersion 5+/-1sec. shall result no anti-soldering and the coverage of dipping into solder must be more than 90%
	TORQUE:	Max. 3kgf applied to nut
	OPERATING FORCE:	1500+/-200gf
	SOLDERING ABILITY:	Per MIL-STD-202F method 208D,max soldering temperature @ 260Celsius degree, flux 5-10sec, duration of solder immersion 5+/-1sec. shall result no anti-soldering and the coverage of dipping into solder must be more than 90%
	COLD TEST:	Stored at temperature -20(+/-2)Celsius degree for 48 hours, shall result no changes to switch's electrical performance
	HOT TEST:	Stored at temperature +65(+/-2)Celsius degree for 48 hours, shall result no changes to switch's electrical performance
HUMIDITY TEST:	Stored at temperature 40(+/-2)Celsius degree with relative humidity 90%~95% for 48 hours, shall result no changes to switch's electrical performance	

	SALT SPRAY RESISTANCE:	Stored at temperature @ 35(+/-3)Celsius degree, and salt solution concentration of 5% with full air temperature @ 47(+/-3) Celsius degree and air pressure 1.0kg for 48 hours. The switch shall result no corrosion as well as no apparent changes to its functional performance. Per ASTM-B117 & JIS-Z371 STD.
MATERIAL CHARACTERISTICS	BASE:	PA66, flame retardant, heat stabilized (UL 94V-0)
	PLUNGER:	Brass, nickel plated
	BUSHING:	Brass, nickel plated
	CAP:	Brass, nickel plated
	COVER:	Stainless steel
	PIVOT PIN:	Brass or POM
	SPRING:	Piano wire
	MOVABLE CONTACT:	Copper alloy, tin plated
	TERMINAL CONTACT:	Copper alloy, tin plated
	ALL TERMINALS:	Copper alloy, tin plated
	HARDWARE:	Nut – brass, nickel plated Washer – steel, nickel plated Ring – POM
SOLDERING & CLEANING RECOMMENDATION	HAND SOLDERING:	Max soldering temperature @ 360Celsius degree, immersion time 4sec.
	WAVE SOLDERING:	No-clean flux wave soldering is recommended so the switch does not require washing after soldering process. Noted, not to have flux migrate inside the switch through the top of the housing or actuator to prevent contamination. Max temperature @ 260Celsius degree (500F) for 3 sec.
	CLEANING PROCESS:	Noted, the switch is “not totally sealed” so it is important not to immerse/spray or clean unsealed areas of the switch during flux removal. Improper cleaning could cause switch deficiencies such as intermittence or open contact failures
PACKAGE	INTERNAL PACKAGING:	1pcs per PE bag
	RoHS IDENTIFICATIONS:	Bag is attached with a label marking “RoHS”

**PRODUCT HANDLING
& STORING**

The switch is suitable for power rated applications, rating recommendation is per aforementioned above (Contact rating section)

Problem relates to terminal oxidization can be prevented by storing product in an environment that is dry and cool with the relative humidity less than 90%. Noted, prior to mounting products onto circuit board as well as for unused units, it is recommended to keep them in the bag and with the bag sealed.

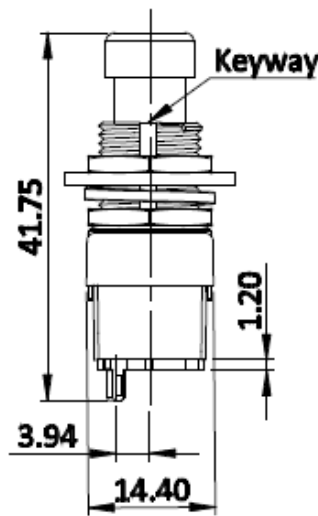
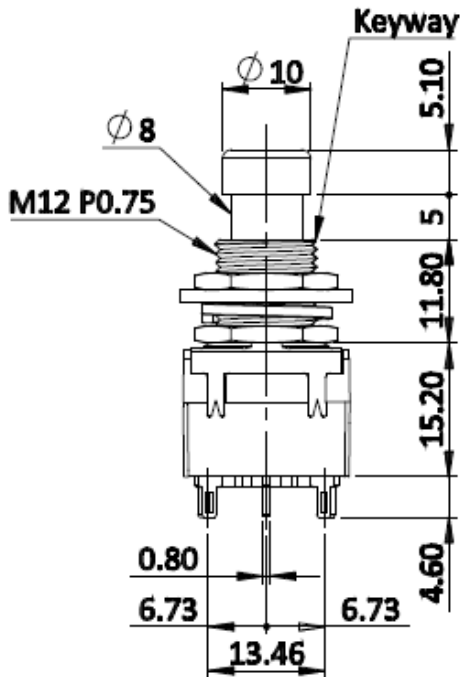

Type	Circuitry Trait	
SPDT		
	ON 2-3	ON 2-1

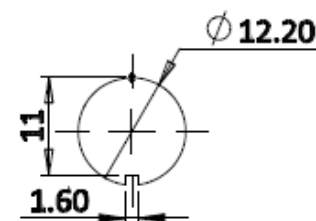
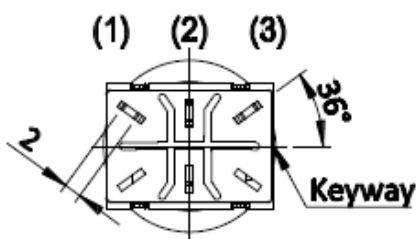

**Panel Thickness :
3.0mm Max.**