

DRG.No.  
**172-xxx**

PART No. SEE TABLE

ISS ALTERATION  
A NEW COMPT DRG

ISOMETRIC VIEW  
SCALE 2:1

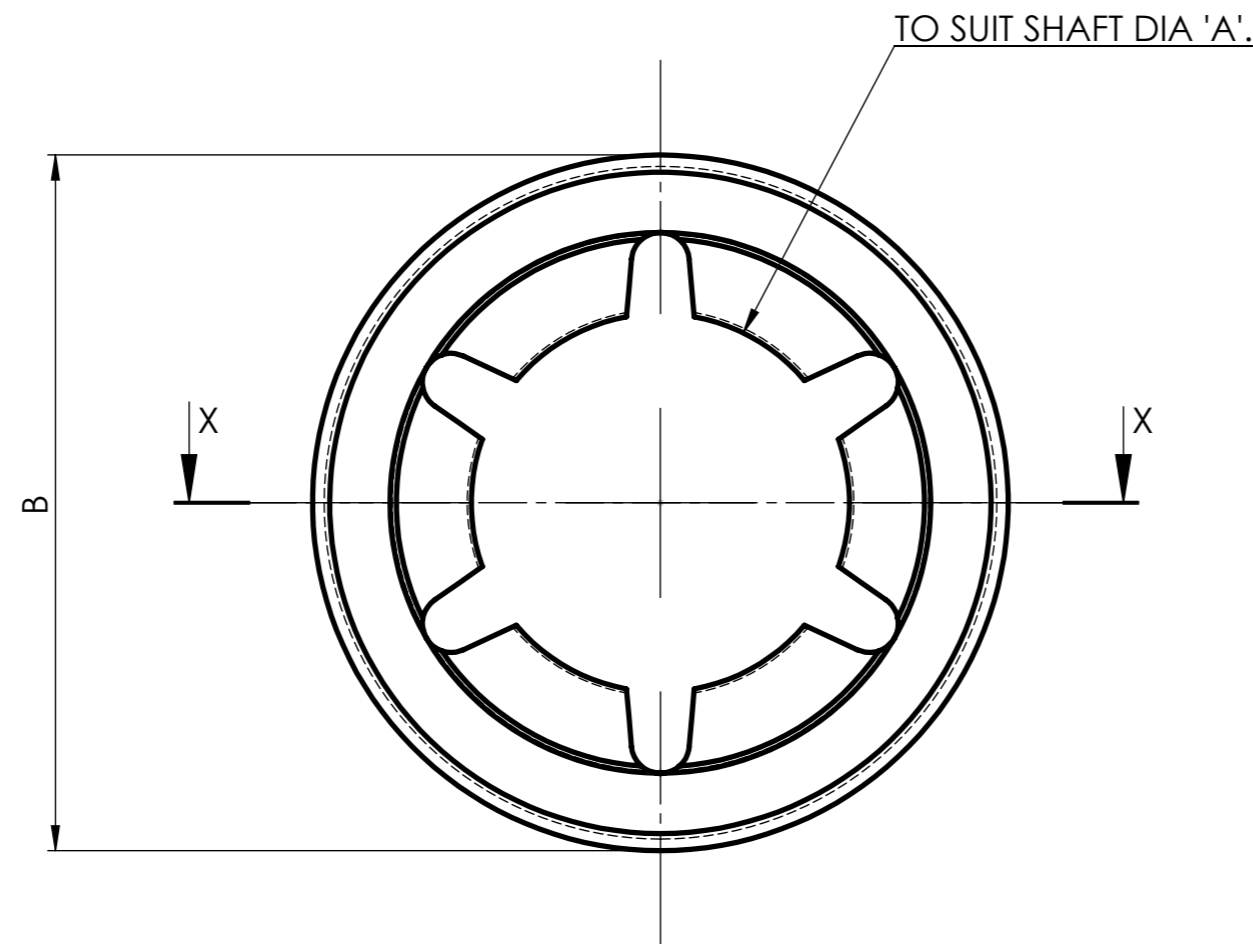
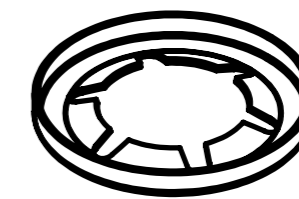

Part No.	A	B	C	D
172 307	2mm	9.7mm	1.3mm	0.2mm
172 313	2.5mm	9.7mm	1.3mm	0.2mm
172 329	3mm	9.7mm	1.3mm	0.2mm
172 335	4mm	11.5mm	1.3mm	0.2mm
172 341	5mm	11.5mm	1.3mm	0.2mm
172 357	6mm	15.2mm	1.3mm	0.25mm
172 379	8mm	15.2mm	1.3mm	0.25mm
172 391	10mm	18.4mm	1.9mm	0.3mm
172 408	12mm	25mm	2.3mm	0.4mm

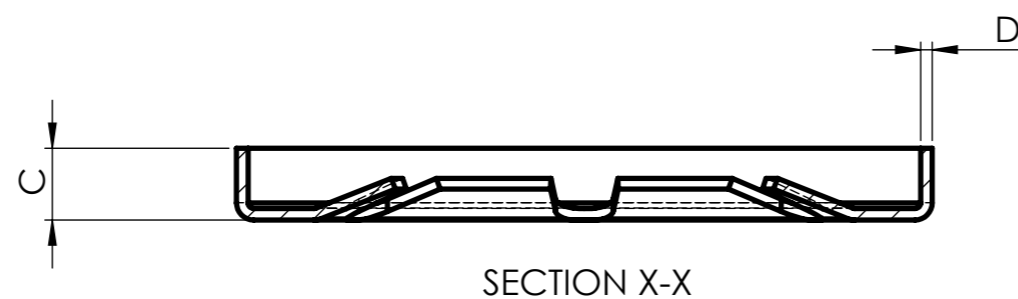

NOTES:  
DRAWING SHOWS 172 391 FIXING, OTHER SIZES MAY VARY.  
TOLERANCES UNLESS OTHERWISE STATED +/-0.13mm



CUSTOMER:		MATERIAL SPECIFICATION BS EN10132-4:2000 C67S SPRING STEEL	DRAWN
CUST.DRG.No.	ISSUE A	HEAT TREATMENT/FINISH AUSTEMPER 500-550HV	CHECKED
TITLE: PUSH ON FIXING			DATE 09/01/13

PROJECTION 	SCALE 5:1	DIMENSIONS ARE IN mm	DO NOT SCALE-IF IN DOUBT ASK
----------------	--------------	----------------------	------------------------------