



### Main

Range of product	Altivar Process ATV900
Product or component type	Variable speed drive
Device application	Industrial application
Device short name	ATV930
Variant	Standard version
Product destination	Asynchronous motors Synchronous motors
Mounting mode	Wall mount
EMC filter	Without EMC filter
IP degree of protection	IP21 conforming to IEC 60529 IP21 conforming to IEC 61800-5-1
Degree of protection	UL type 1 conforming to UL 508C
Type of cooling	Forced convection
Supply frequency	50...60 Hz (+/- 5 %)
Network number of phases	3 phases
[Us] rated supply voltage	200...240 V (- 15...10 %)
Motor power kW	1.5 kW (heavy duty) 2.2 kW (normal duty)
Motor power hp	3 hp (normal duty) 2 hp (heavy duty)
Line current	7.2 A at 240 V (normal duty) 5.3 A at 240 V (heavy duty) 8.4 A at 200 V (normal duty) 6 A at 200 V (heavy duty)
Prospective line Isc	50 kA
Apparent power	3 kVA at 240 V (normal duty) 2.2 kVA at 240 V (heavy duty)
Continuous output current	8 A at 4 kHz (heavy duty) 11.2 A at 4 kHz (normal duty)
Maximum transient current	12 A during 60 s (heavy duty) 13.4 A during 60 s (normal duty)

Asynchronous motor control profile	Constant torque standard Variable torque standard Optimized torque mode
Synchronous motor control profile	Permanent magnet motor
Speed drive output frequency	0.1...500 Hz
Nominal switching frequency	4 kHz
Switching frequency	2...16 kHz adjustable 4...16 kHz with derating factor
Safety function	STO (safe torque off) SIL 3
Discrete input logic	16 preset speeds
Communication port protocol	Modbus serial Modbus TCP Ethernet IP
Option card	Slot A : communication module for EtherCAT Slot A : communication module for CANopen SUB-D 9 Slot B : 5/12 V digital encoder interface module Slot A : communication module for CANopen screw terminals Slot A/slot B/slot C : output relay extension module Slot A : communication module for Profinet Slot A : communication module for DeviceNet Slot B : resolver encoder interface module Slot A : communication module for Profibus DP V1 Slot A : communication module for CANopen daisy chain RJ45 Slot A/slot B/slot C : digital and analog I/O extension module Slot B : analog encoder interface module

## Offer Sustainability

Sustainable offer status	Green Premium product
RoHS (date code: YYWW)	Compliant - since 1526 - Schneider Electric declaration of conformity <a href="#">Schneider Electric declaration of conformity</a>
REACH	Reference contains SVHC above the threshold - Go to CaP for more details <a href="#">Go to CaP for more details</a>
Product environmental profile	Available
Product end of life instructions	Available

## Complementary

Output voltage	<= power supply voltage
Motor slip compensation	Adjustable Automatic whatever the load Can be suppressed Not available in permanent magnet motor law
Acceleration and deceleration ramps	Linear adjustable separately from 0.01 to 9000 s S, U or customized
Braking to standstill	By DC injection
Protection type	Motor : motor phase break Motor : thermal protection Motor : safe torque off Drive : thermal protection Drive : safe torque off Drive : line supply overvoltage Drive : line supply undervoltage Drive : line supply phase loss Drive : overheating Drive : overload of output voltage Drive : overvoltages on the DC bus Drive : break on the control circuit Drive : overcurrent between output phases and earth Drive : short-circuit protection Drive : motor phase break Drive : overspeed
Frequency resolution	Display unit : 0.1 Hz Analog input : 0.012/50 Hz
Electrical connection	Line side, screw terminal : 2.5...6 mm <sup>2</sup> (AWG 14...AWG 10)

Motor, screw terminal : 2.5...6 mm<sup>2</sup> (AWG 14...AWG 10)  
 Control, screw terminal : 0.5...1.5 mm<sup>2</sup> (AWG 20...AWG 16)  
 DC bus, screw terminal : 2.5...6 mm<sup>2</sup> (AWG 14...AWG 10)

Type of connector	2 RJ45 (on the control block) for Ethernet IP/Modbus TCP 1 RJ45 (on the control block) for Modbus serial
Physical interface	2-wire RS 485 for Modbus serial
Transmission frame	RTU for Modbus serial
Transmission rate	4.8, 9.6, 19.2, 38.4 kbit/s for Modbus serial 10/100 Mbit/s for Ethernet IP/Modbus TCP
Exchange mode	Half duplex, full duplex, autonegotiation for Ethernet IP/Modbus TCP
Data format	8 bits, configurable odd, even or no parity for Modbus serial
Type of polarization	No impedance for Modbus serial
Number of addresses	1...247 for Modbus serial
Method of access	Slave for Modbus TCP
Supply	External supply for digital inputs : 24 V DC (19...30 V) current ≤ 1.25 mA (overload and short-circuit protection) Internal supply for reference potentiometer (1 to 10 kOhm) : 10.5 V DC +/- 5 % current ≤ 10 mA (overload and short-circuit protection) Internal supply for digital inputs and STO : 24 V DC (21...27 V) current ≤ 200 mA (overload and short-circuit protection)
Local signalling	1 LED(s) red for presence of voltage 2 LED(s) dual colour for communication module status 3 LED(s) mono/dual colour for local diagnostic 5 LED(s) dual colour for embedded communication status
Width	144 mm
Height	350 mm
Depth	206 mm
Product weight	4.5 kg
Analogue input number	3
Analogue input type	Software-configurable current AI1, AI2, AI3 : 0...20 mA impedance 250 Ohm, resolution 12 bits Software-configurable voltage AI1, AI2, AI3 : 0...10 V DC impedance 30 kOhm, resolution 12 bits
Discrete input number	10
Discrete input type	Programmable as pulse input DI7, DI8 0...30 kHz : 24 V DC (≤ 30 V) Safe torque off STOA, STOB : 24 V DC (≤ 30 V) impedance > 2.2 kOhm Programmable DI1...DI8 : 24 V DC (≤ 30 V) impedance 3.5 kOhm
Input compatibility	Discrete input DI1...DI8 : level 1 PLC conforming to EN/IEC 61131-2 Pulse input DI7, DI8 : level 1 PLC conforming to IEC 65A-68 Discrete input STOA, STOB : level 1 PLC conforming to EN/IEC 61131-2
Discrete input logic	DI1...DI8, positive logic (source) : < 5 V (state 0) > 11 V (state 1) STOA, STOB, positive logic (source) : < 5 V (state 0) > 11 V (state 1) DI7, DI8, positive logic (source) : < 0.6 V (state 0) > 2.5 V (state 1) DI1...DI8, negative logic (sink) : > 16 V (state 0) < 10 V (state 1)
Analogue output number	2
Analogue output type	Software-configurable current AQ1, AQ2 : 0...20 mA impedance 500 Ohm, resolution 10 bits Software-configurable voltage AQ1, AQ2 : 0...10 V DC impedance 470 Ohm, resolution 10 bits
Discrete output number	2
Discrete output type	Logic output DQ+ : 0...1 kHz (≤ 30 V) DC, < 100 mA Programmable as pulse output DQ+ : 0...30 kHz (≤ 30 V) DC, < 20 mA Logic output DQ- : 0...1 kHz (≤ 30 V) DC, < 100 mA
Sampling duration	Discrete input DI1...DI8 : 2 ms (+/- 0.5 ms) Analog output AQ1, AQ2 : 5 ms (+/- 1 ms) Pulse input DI7, DI8 : 5 ms (+/- 1 ms) Analog input AI1, AI2, AI3 : 1 ms (+/- 1 ms)
Accuracy	Analog input AI1, AI2, AI3 : +/- 0.6 % for a temperature variation 60 °C Analog output AQ1, AQ2 : +/- 1 % for a temperature variation 60 °C
Linearity error	Analog output AQ1, AQ2 : +/- 0.2 % Analog input AI1, AI2, AI3 : +/- 0.15 % of maximum value
Relay output number	3
Relay output type	Configurable relay logic R2 : sequence relay NO electrical durability 1000000 cycles Configurable relay logic R3 : sequence relay NO electrical durability 1000000 cycles Configurable relay logic R1 : fault relay NO/NC electrical durability 100000 cycles
Refresh time	Relay output R1, R2, R3 : 5 ms (+/- 0.5 ms)

Minimum switching current	Relay output R1, R2, R3 : 5 mA at 24 V DC
Maximum switching current	Relay output R1 on inductive load (cos phi = 0.4 and L/R = 7 ms) : 2 A at 250 V AC Relay output R2, R3 on resistive load (cos phi = 1) : 5 A at 30 V DC Relay output R2, R3 on inductive load (cos phi = 0.4 and L/R = 7 ms) : 2 A at 250 V AC Relay output R2, R3 on inductive load (cos phi = 0.4 and L/R = 7 ms) : 2 A at 30 V DC Relay output R1 on resistive load (cos phi = 1) : 3 A at 30 V DC Relay output R2, R3 on resistive load (cos phi = 1) : 5 A at 250 V AC Relay output R1 on resistive load (cos phi = 1) : 3 A at 250 V AC Relay output R1 on inductive load (cos phi = 0.4 and L/R = 7 ms) : 2 A at 30 V DC
Isolation	Between power and control terminals
Specific application	Process
IP degree of protection	IP21

## Environment

Insulation resistance	> 1 mOhm at 500 V DC for 1 minute to earth
Noise level	54.5 dB conforming to 86/188/EEC
Power dissipation in W	32 W (natural convection) at 200 V switching frequency 4 kHz 74 W (forced convection) at 200 V switching frequency 4 kHz
Volume of cooling air	38 m <sup>3</sup> /h
Operating position	Vertical +/- 10 degree
THDI	<= 48 % full load conforming to IEC 61000-3-12
Electromagnetic compatibility	Conducted radio-frequency immunity test level 3 conforming to IEC 61000-4-6 Radiated radio-frequency electromagnetic field immunity test level 3 conforming to IEC 61000-4-3 Electrical fast transient/burst immunity test level 4 conforming to IEC 61000-4-4 1.2/50 µs - 8/20 µs surge immunity test level 3 conforming to IEC 61000-4-5 Electrostatic discharge immunity test level 3 conforming to IEC 61000-4-2
Pollution degree	2 EN/IEC 61800-5-1
Vibration resistance	1.5 mm peak to peak (f = 2...13 Hz) conforming to IEC 60068-2-6 1 gn (f = 13...200 Hz) conforming to IEC 60068-2-6
Shock resistance	15 gn during 11 ms conforming to IEC 60068-2-27
Relative humidity	5...95 % without condensation conforming to IEC 60068-2-3
Ambient air temperature for operation	50...60 °C with derating factor -15...50 °C without derating
Ambient air temperature for storage	-40...70 °C
Operating altitude	<= 1000 m without derating 1000...4800 m with current derating 1 % per 100 m
Environmental characteristic	Dust pollution resistance class 3S3 conforming to EN/IEC 60721-3-3 Chemical pollution resistance class 3C3 conforming to EN/IEC 60721-3-3
Standards	EN/IEC 61800-5-1 IEC 60721-3 EN/IEC 61800-3 (environment 1 category C2) EN/IEC 61800-3 (environment 2 category C3) IEC 61508 UL 508C EN/IEC 61800-3 IEC 61000-3-12 IEC 13849-1
Product certifications	CSA TÜV UL REACH
Marking	CE

Dimensions

IP21 / UL Type 1 Drives - Right Side, Front and Rear View

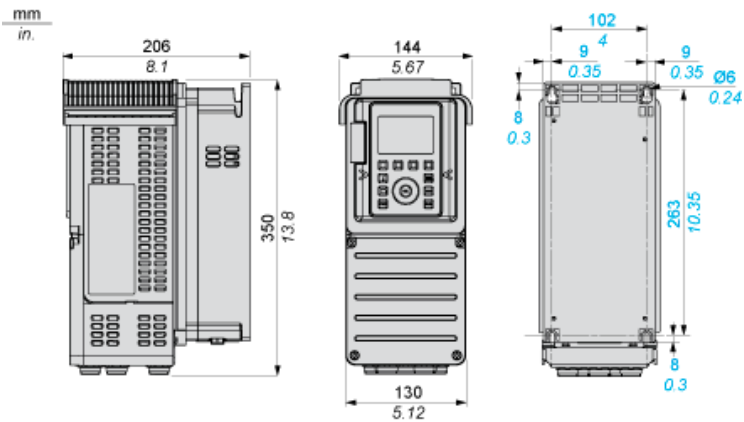

Mounting Types

Mounting Type A: Individual IP21

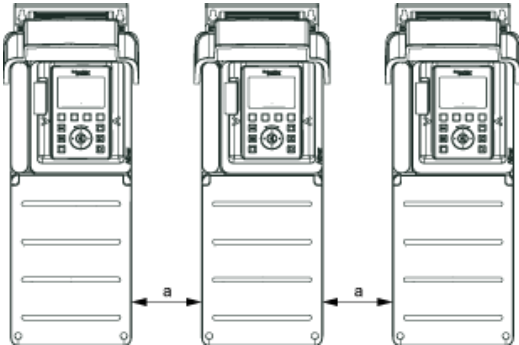

$a \geq 100 \text{ mm (3.94 in.)}$

Mounting Type B: Side by Side IP20

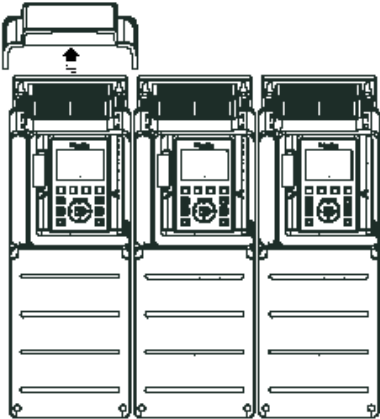

---

Mounting Types

---

Mounting Type A: Individual IP21

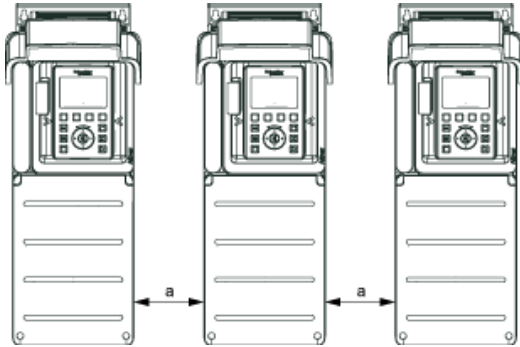

$a \geq 100 \text{ mm (3.94 in.)}$

Mounting Type B: Side by Side IP20

