



Data Sheet

Heating cable

RS stock numbers

665-7450, 665-7453, 665-7457, 665-7466, 665-7469, 665-7463, 665-7586, 703-3186, 703-3202, 703-3215, 703-3218, 703-3212, 703-3221, 703-3224, 703-3136, 703-3139, 703-3133, 703-3142, 703-3145, & 703-3149

RS Cut to length heat tracing system

The RS heater cable is a parallel resistance, cut to length on site self regulating heating cable designed for frost protection and low temperature maintenance.

The heating tape adjusts heat output to equal the heat loss from the pipe work. As pipe temperature falls under no-flow conditions or due to decreases in external or internal temperature, the output increases. As the pipe temperature increases under flow conditions or as a result of increasing external or internal temperature so output decreases.

The RS Heater Cable is designed to be cut from reel lengths and site terminated to suit pipework.

The heating tape has a core comprising two bus-wire conductors contained within an extruded semi-conductive self limiting heater core with an outer insulating polyolefin sheath.

The tape has an earth protection screen in the form of a Foil Jacket covering a multi strand earth lead.

The tape is finished with a further protective thermoplastic outer sheath over the earth screen.

Features

- Cut to length
- Easy to terminate
- Suitable for internal and external heating applications

Specification

Location _____ Non hazardous areas

Construction

Conductors _____ Copper stranded 1.23mm²
 Core _____ Semi-conductive Polymer.
 Outer Sheath _____ Polyolefin
 Width _____ 13mm
 Thickness _____ 5mm

Withstand temperatures

Energised _____ 65°C
 Un-energised _____ 65°C

Ratings: Wattage @10°C

240V

_____ 10watts/m (665-7450, 665-7453, 665-7457, 703-3186)
 Max circuit Length _____ 200m
 _____ 20watts/m (665-7466, 665-7469, 665-7463, 665-7586)
 Max circuit Length _____ 155m
 _____ 30watts/m (703-3206, 703-3215, 703-3218)
 Max circuit Length _____ 120m
 _____ 40watts/m (703-3212, 703-3221, 703-3224)
 Max circuit Length _____ 100m

110V

_____ 10watts/m (703-3136, 703-3139, 703-3133)
 Max circuit Length _____ 78m
 _____ 20watts/m (703-3142, 703-3145, 703-3149)
 Max circuit Length _____ 50m

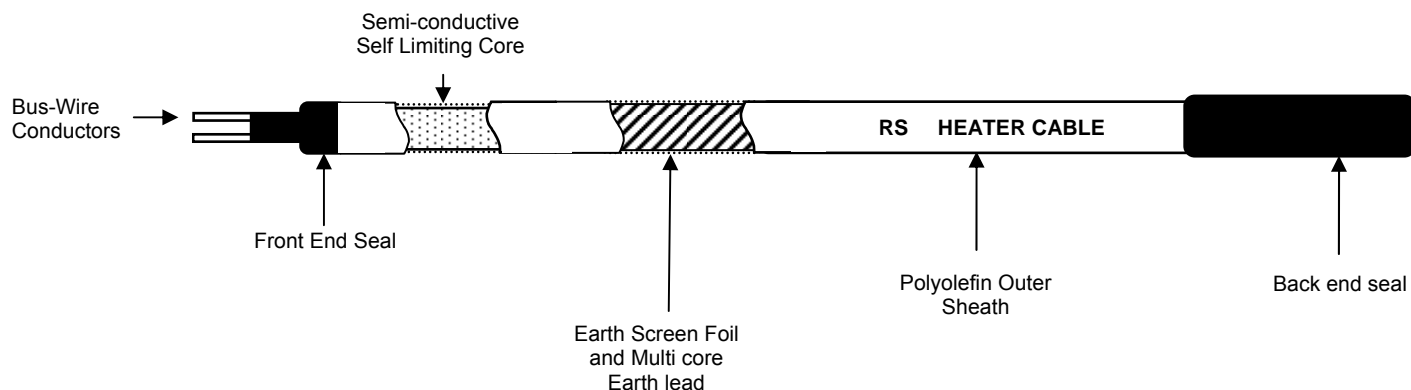

Electrical

Circuit Breaker type C to EN60898
 A 30mA trip Residual Current Circuit Device (RCCB) or
 Earth Leakage Circuit Breaker (ELCB) is
 recommended for use with heating tapes.

Output

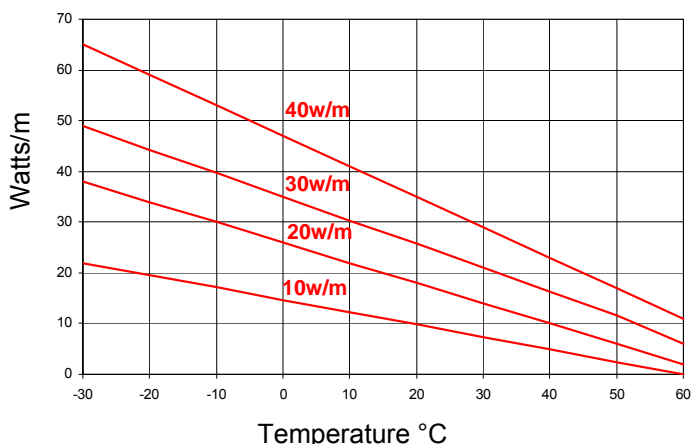

To calculate heat loss per metre of pipe:-

$$\text{Heat losses } W/m = \frac{2\pi k (T_p - T_a)}{\ln\left(\frac{D_2}{D_1}\right)}$$

where:-

k = Thermal Conductivity of insulation layer at its mean temperature

T_p = Maintain Temperature

T_a = Minimum Ambient temp

D₁ = Inside Diameter of the Insulation Layer

D₂ = Outside Diameter of the Insulation Layer

Thermal Conductivity (k) for Mineral/Glass Fibre

Mean Temperature °C	10	50	100	200
k	0.032	0.035	0.43	0.062

A Design Factor Allowance should be taken of:
 Maximum heater resistance tolerance (± 10%) and
 Voltage variation (± 6%)

$$= \frac{1.1}{(0.94)^2} = 1.25 \times \text{Heat Loss.}$$

A further design factor of 10% may be added.

Installation

- Heating tape should be installed on clean, dry pipe free from burrs, weld splatter or any rough, sharp projections.
- Heating tape may be straight traced or spiralled along the pipe. If straight traced, the heating tape should be held in place with adhesive tape at 300mm intervals. For spiral tracing, fixing at 1m intervals is suitable.
- Use the correct adhesive tape suitable for the temperature application.
- A 30mA trip Residual Current Circuit Device (RCCB) or Earth Leakage Circuit Breaker (ELCB) is recommended for use with heating tapes.
- If in doubt about electrical installation consult a qualified electrician.
- Use mineral or glass fibre insulation and ensure that it is kept dry for maximum efficiency.
- Fit warning labels supplied on the outside of thermal insulation at approximately 3-meter intervals.
- For PVC, ABS, Polythene and other 'Plastic' pipes use heating tape not exceeding 12 watts per meter and having an earth screen covering. It is recommended that heating tape be covered in 50mm wide adhesive aluminium foil. An RCC or ELCB unit must be used in conjunction with this type of installation.
- It is recommended that all Heating tape should be installed in conjunction with a thermostatic controller.
- Heating cable should be terminated using **RS 665-7431** termination kit.

HEATING TAPE STRAIGHT TRACED FIXED AT MAX 300MM

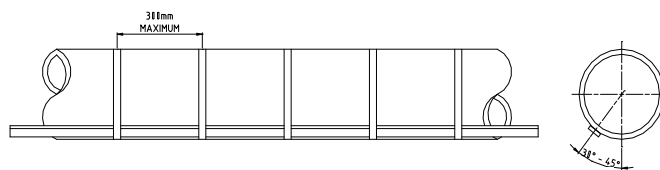

HEATING TAPE SPIRALLY TRACED FIXED AT 1000MM

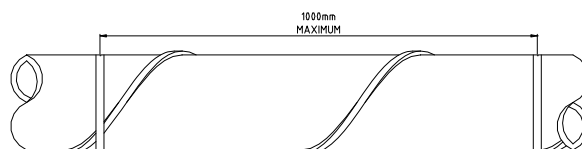



ENGLISH

Instruction Leaflet
Bendienungsanleitung
Hojas de instrucciones
Feuille d'instructions
Foglio d'istruzioni
Betjeningsvejledning
Instructies
Instruktionsfolder



Heating Cable Termination Kit **GB**

Heizband-Abschluss-Set **D**

Kit de terminals para cable de calentamiento **E**

Kit de terminal de cable chauffant **F**

Kit di terminazione cavo di riscaldamento **I**

Aftslutningssæt til varmekabler **DK**

Aansluitset voor verwarmingskabel **NL**

Anslutningssats till värmekabel

665-7472 for use with Heating Cables:

665-7450, 665-7453, 665-7457, 665-7466, 665-7469, 665-7463, 665-7586, 703-3186, 703-3202, 703-3215, 703-3218, 703-3212, 703-3221, 703-3224, 703-3136, 703-3139, 703-3133, 703-3142, 703-3145, & 703-3149

The information contained within this data sheet regarding applications and installation of RS Parallel Heating Tape is for guidance only. The user must satisfy himself that the tape is suitable for the intended application and does not contravene any safety requirements. If in doubt consult BS EN 62395 or other appropriate specifications or regulations.

When used with Heat cable (RS stock no. 665-7450, 665-7453, 665-7457, 665-7466, 665-7469 & 665-7463) this kit will be sufficient for three sets of terminations. The kit consists of the following:

- 3 Back end seal
- 3 Front end seal
- 3 Earth heat shrink
- 3 Warning labels
- 3 M25 Glands c/w sealing grommet

RS Kit Ref 665-7586 consists of the following:

- 30m Self Regulating Heating Tape 20w/m @10°C 240v
- 1 Back end seal
- 1 Front end seal
- 1 Roll fixing tape
- 5 Warning labels

RS Kit Ref 703-3186 consists of the following:

- 30m Self Regulating Heating Tape 10w/m @10°C 240v
- 1 Back end seal
- 1 Front end seal
- 1 Roll fixing tape
- 5 Warning labels

FRONT TERMINATION

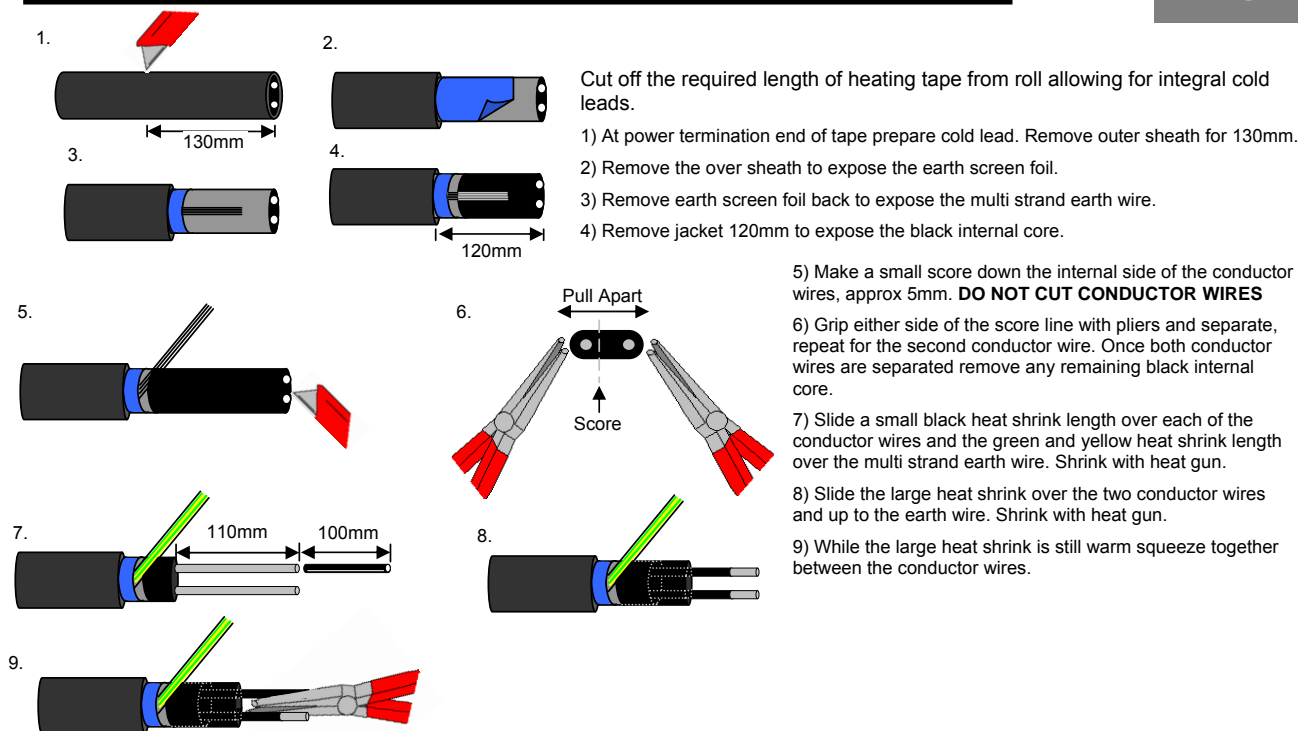

REAR TERMINATION

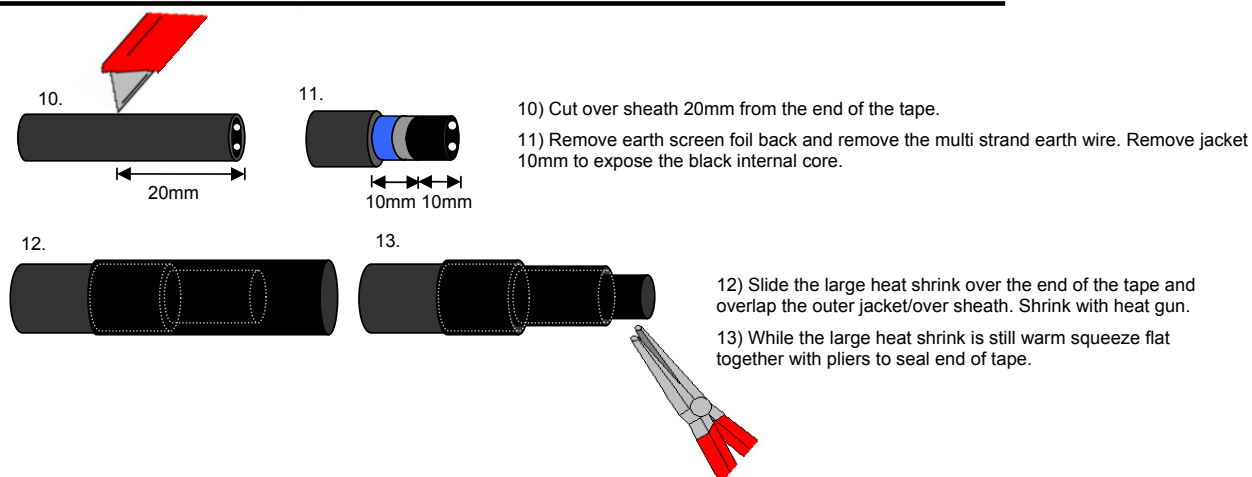

- Intended use(s) Freeze protection and temperature maintenance, hot water lines, oil and chemical lines, sprinkler system mains and supply piping (as listed in Clause 1 BS EN 62395).
- Ground-fault equipment protection is required for each circuit
- De-energize all power circuits before installation or servicing
- Keep ends of trace heaters and kit components dry before and during installation
- Caution: Do not use in areas subject to high mechanical loads or impact, This heating tape is intended for use in applications with low risk of mechanical damage.
- The metal sheath, braid, screen or equivalent electrically conductive covering of the trace heater must be connected to an earth terminal
- The presence of the trace heaters shall be made evident by the posting of caution signs or markings at appropriate locations and/or at frequent intervals along the circuit.
- Heating tape should be installed on clean, dry pipe free from burrs, weld splatter or any rough, sharp projections.
- Heating tape may be straight traced or spiralled along the pipe. If straight traced, the heating tape should be held in place with adhesive tape at 300mm intervals. For spiral tracing, fixing at 1m intervals is suitable.
- Use the correct adhesive tape suitable for the temperature application.
- If in doubt about electrical installation consult a qualified electrician.
- Use mineral or glass fibre insulation and ensure that it is kept dry.
- Fit warning labels supplied on the outside of thermal insulation at approximately 3-meter intervals.
- For PVC, ABS, Polythene and other 'Plastic' pipes use heating tape not exceeding 12 watts per meter and having an earth screen covering. It is recommended that heating tape be covered in 50mm wide adhesive aluminium foil. An RCC or ELCB unit must be used in conjunction with this type of installation.