

Notes: (Unless Otherwise Specified)

1. Waterproof Rate: IP67.
2. Suitable Cable OD= 4.0 mm to 8.0 mm
3. Recommend Cover Torque: 6.0 to 7.0 Kgf-cm.
4. Recommend Gland Nut Torque: 9.0 to 10.0 Kgf-cm.
5. RoHS Compliant.

REV	ECN#	DESCRIPTION OF REVISION	DRAW BY DATE	CHECK BY DATE	APPROVE BY DATE
A0		Mass Production	Joyce 08/14/12	Lucas 08/14/12	Ray 08/14/12

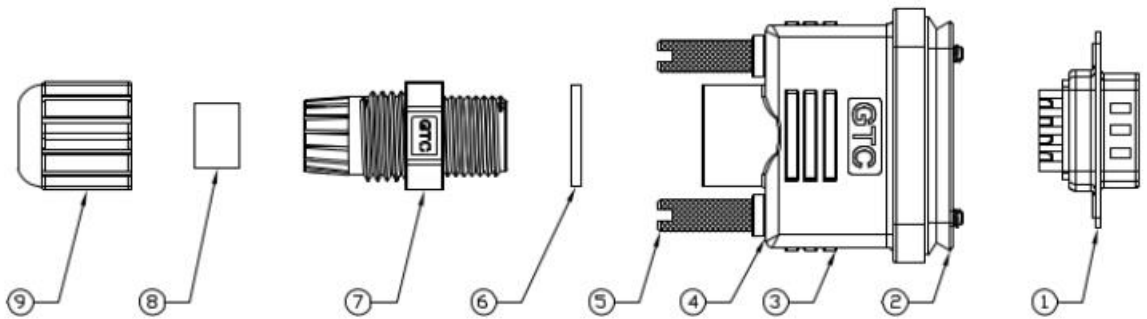

9	Gland Nut	Thermoplastic Color: Black	1
8	Gland	Silicone Color: Black	1
7	Cover	Thermoplastic Color: Black	1
6	Gasket	EPDM Color: Black	1
5	Screw	Cutting Iron Finish: Ni Plated	2
4	Gasket	EPDM Color: Black	2
3	Housing	Thermoplastic Color: Black	1
2	Seal	EPDM Color: Black	1
1	D-SUB HD 15P Male	Housing: Thermoplastic, Color: Black Contacts: Copper Alloy, Finish: Au Plated Shell: SPCC, Finish: Ni Plated	1
Item	Part Name	Material / Finish	Qty

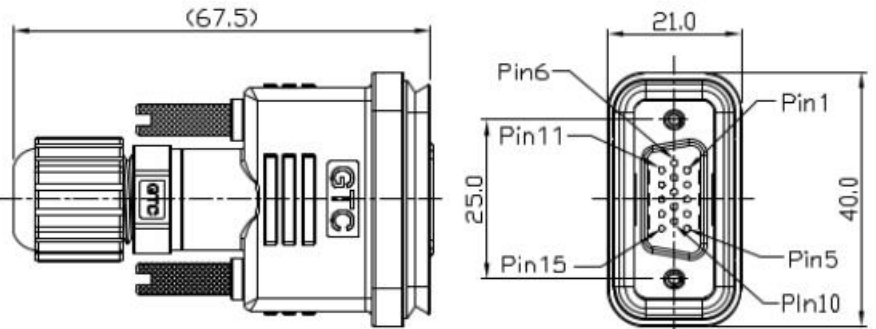

Mating Part:  
122-3037

TITLE						REV.	
D-SUB HD 5A 15P Field Installable Cable End Male Solder						A0	
	B	1:1	Joyce 08/14/12	Lucas 08/14/12	Ray 08/14/12	XX ± 0.5 X.XX ± 0.2	X.XXX ± 0.05 ANGLES ± 1°
THIRD ANGLE PROJECTION	SIZE	SCALE	DRAW / DATE	CHECK / DATE	APPROVE / DATE	TOLERANCES	UNIT
						mm	1/1
							SHEET

RS Stock No  
122-3046