

# ATSU01N212LT

soft starter for asynchronous motor, Altistart U01, TeSys U, ATSU01, 12A, 200...480V, 2.2...5.5kW



## Main

Range of product	Altistart U01 and TeSys U
Product or component type	Soft starter
Product destination	Asynchronous motors
Product specific application	Simple machine
Device short name	ATSU01
Network number of phases	3 phases
[Us] rated supply voltage	200...480 V - 10...10 %
Motor power kW	2.2 KW, 3 phases at 230 V 5.5 KW, 3 phases at 400 V 3 kW, 3 phases at 230 V
Motor power hp	3 Hp, 3 phases at 230 V 7.5 hp, 3 phases at 460 V
lCL starter rating	12 A
Utilisation category	AC-53B conforming to EN/IEC 60947-4-2
Current consumption	65 mA
Type of start	Start with voltage ramp
Power dissipation in W	1.5 W at full load and at end of starting 121.5 W in transient state

## Complementary

Assembly style	With heat sink
Function available	Integrated bypass
Supply voltage limits	180...528 V
Supply frequency	50...60 Hz - 5...5 %
Network frequency	47.5...63 Hz
Output voltage	$\leq$ power supply voltage
[Uc] control circuit voltage	24 V DC +/- 10 %
Starting time	1 s / 100 5 s / 20 10 s / 10 Adjustable from 1 to 10 s
Deceleration time symb	Adjustable from 1 to 10 s
Starting torque	30...80 % of starting torque of motor connected directly on the line supply
Discrete input type	Logic (LI1, LI2, BOOST) stop, run and boost on start-up functions $\leq$ 8 mA 27 kOhm
Discrete input voltage	24...40 V
Input output isolation	Galvanic between power and control
Discrete input logic	Positive LI1, LI2, BOOST at State 0: $<$ 5 V and $\leq$ 0.2 mA at State 1: $>$ 13 V, $\geq$ 0.5 mA
Discrete output current	2 A DC-13 3 A AC-15
Discrete output type	Open collector logic LO1 end of starting signal Relay outputs R1A, R1C NO
Discrete output voltage	24 V (voltage limits: 6...30 V) open collector logic
Minimum switching current	10 mA at 6 V DC for relay outputs

The information provided in this documentation contains general descriptions and/or technical characteristics of the performance of the products contained herein. This documentation is not intended as a substitute for and is not to be used for determining suitability or reliability of these products for specific user applications. It is the duty of any such user or integrator to perform the appropriate and complete risk analysis, evaluation and testing of the products with respect to the relevant specific application or use thereof. Neither Schneider Electric Industries SAS nor any of its affiliates or subsidiaries shall be responsible or liable for misuse of the information contained herein.

Maximum switching current	Relay outputs: 2 A at 30 V DC cos phi = 0.5 and L/R = 20 ms inductive load Relay outputs: 2 A at 250 V AC AC-15 cos phi = 0.5 and L/R = 20 ms inductive load
Maximum switching voltage	440 V relay outputs
Display type	1 LED (green) for starter powered up 1 LED (yellow) for nominal voltage reached
Tightening torque	1.9...2.5 N.M 0.5 N.m
Electrical connection	4 mm screw clamp terminal - rigid 1 1...10 mm <sup>2</sup> AWG 8 power circuit Screw connector - rigid 1 0.5...2.5 mm <sup>2</sup> AWG 14 control circuit 4 mm screw clamp terminal - rigid 2 1...6 mm <sup>2</sup> AWG 10 power circuit Screw connector - rigid 2 0.5...1 mm <sup>2</sup> AWG 17 control circuit Screw connector - flexible with cable end 1 0.5...1.5 mm <sup>2</sup> AWG 16 control circuit 4 mm screw clamp terminal - flexible without cable end 1 1.5...10 mm <sup>2</sup> AWG 8 power circuit Screw connector - flexible without cable end 1 0.5...2.5 mm <sup>2</sup> AWG 14 control circuit 4 mm screw clamp terminal - flexible with cable end 2 1...6 mm <sup>2</sup> AWG 10 power circuit 4 mm screw clamp terminal - flexible without cable end 2 1.5...6 mm <sup>2</sup> AWG 10 power circuit Screw connector - flexible without cable end 2 0.5...1.5 mm <sup>2</sup> AWG 16 control circuit
Marking	CE
Operating position	Vertical +/- 10 degree
Height	234 mm
Width	45 mm
Depth	150 mm
Product weight	0.34 kg
Motor power range AC-3	2.2...3 kW at 200...240 V 3 phases 4...6 kW at 380...440 V 3 phases
Motor starter type	Soft starter

## Environment

Electromagnetic compatibility	Conducted and radiated emissions level B conforming to CISPR 11 Conducted and radiated emissions level B conforming to IEC 60947-4-2 Damped oscillating waves level 3 conforming to IEC 61000-4-12 Electrostatic discharge level 3 conforming to IEC 61000-4-2 EMC immunity conforming to EN 50082-1 EMC immunity conforming to EN 50082-2 Harmonics conforming to IEC 1000-3-2 Harmonics conforming to IEC 1000-3-4 Immunity to electrical transients level 4 conforming to IEC 61000-4-4 Immunity to radiated radio-electrical interference level 3 conforming to IEC 61000-4-3 Voltage/Current impulse level 3 conforming to IEC 61000-4-5 Conducted and radiated emissions level 3 conforming to IEC 61000-4-6 Immunity to conducted interference caused by radio-electrical fields conforming to IEC 61000-4-11
Standards	EN/IEC 60947-4-2
Product certifications	UL CCC C-Tick CSA
IP degree of protection	IP20
Pollution degree	2 conforming to EN/IEC 60947-4-2
Vibration resistance	1 gn (f= 13...150 Hz) conforming to EN/IEC 60068-2-6 1.5 mm peak to peak (f= 3...13 Hz) conforming to EN/IEC 60068-2-6
Shock resistance	15 gn for 11 ms conforming to EN/IEC 60068-2-27
Relative humidity	5...95 % without condensation or dripping water conforming to EN/IEC 60068-2-3
Ambient air temperature for operation	-10...40 °C (without derating) 40...50 °C (with current derating of 2 % per °C)
Ambient air temperature for storage	-25...70 °C conforming to EN/IEC 60947-4-2
Operating altitude	<= 1000 m without derating > 1000 m with current derating of 2.2 % per additional 100 m

## Packing Units

Unit Type of Package 1	PCE
Number of Units in Package 1	1
Package 1 Height	5.5 cm
Package 1 Width	17.5 cm
Package 1 Length	15.0 cm
Package 1 Weight	453.0 g
Unit Type of Package 2	S03
Number of Units in Package 2	14
Package 2 Height	30.0 cm
Package 2 Width	30.0 cm
Package 2 Length	40.0 cm
Package 2 Weight	6.889 kg

## Offer Sustainability

REACH Regulation	<a href="#">REACH Declaration</a>
REACH free of SVHC	Yes
EU RoHS Directive	Pro-active compliance (Product out of EU RoHS legal scope) <a href="#">EU RoHS Declaration</a>
Toxic heavy metal free	Yes
Mercury free	Yes
China RoHS Regulation	<a href="#">China RoHS Declaration</a>
RoHS exemption information	<a href="#">Yes</a>
Circularity Profile	<a href="#">End Of Life Information</a>
WEEE	The product must be disposed on European Union markets following specific waste collection and never end up in rubbish bins
California proposition 65	WARNING: This product can expose you to chemicals including: Lead and lead compounds, which is known to the State of California to cause cancer and birth defects or other reproductive harm. For more information go to <a href="http://www.P65Warnings.ca.gov">www.P65Warnings.ca.gov</a>

## Contractual warranty

Warranty	18 months
----------	-----------

Dimensions

With TeSys U Combination (Non Reversing Power Base)

Mounting on symmetrical (35 mm) rail with power connector between ATS and TeSys U.

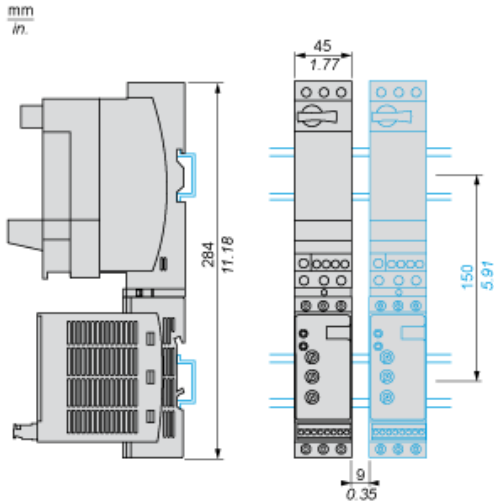

With TeSys U Combination (Non Reversing or Reversing Power Base)

Side by side mounting

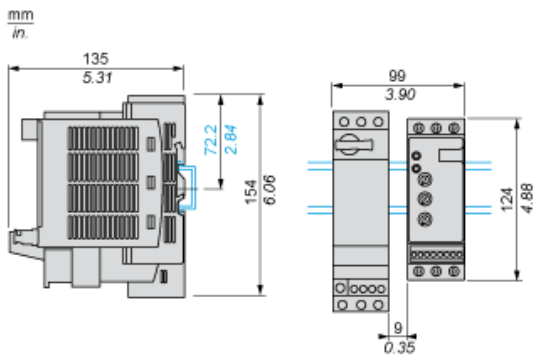

Power Wiring

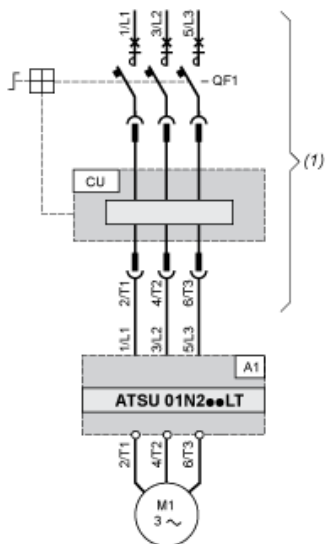

- (1) TeSys U  
A1 : Soft start/soft stop unit  
QF1 :TeSys U controller-starter  
CU : TeSys U control unit

With Reversing Unit

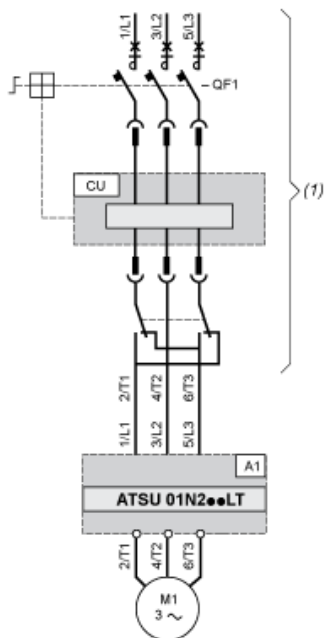

- (1) TeSys U with reversing unit  
A1 : Soft start/soft stop unit  
QF1 :TeSys U controller-starter  
CU : TeSys U control unit

Control Wiring



A1 : Soft start/soft stop unit

R1A, Relay output NO

R1C :

COM Commun

LI1, Logic inputs (stop and run functions)

LI2 :

BOOST Logic input (boost on start-up function)

LO1 :Logic output

---

Functional Diagram Automatic 2-wire Control

---

Without Deceleration

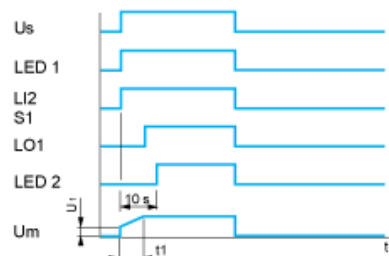

Us : Power supply voltage  
LED Green LED  
1 :  
LI2 : Logic input  
S1 : Pushbutton  
LED Yellow LED  
2 :  
Um : Motor voltage  
t1 : Acceleration time can be controlled by a potentiometer  
U1 : Starting time can be controlled by a potentiometer

With and without Deceleration

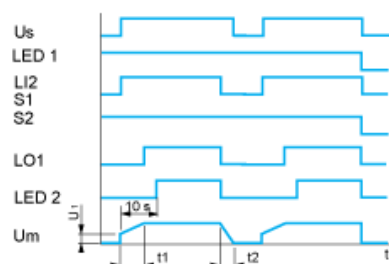

Us : Power supply voltage  
LED Green LED  
1 :  
LI2 : Logic input  
S1, Pushbuttons  
S2 :  
LO1 : Logic output  
LED Yellow LED  
2 :  
Um : Motor voltage  
t1 : Acceleration time can be controlled by a potentiometer  
t2 : Deceleration time can be controlled by a potentiometer  
U1 : Starting time can be controlled by a potentiometer

---

Functional Diagram Automatic 3-wire Control

---

## Without Deceleration

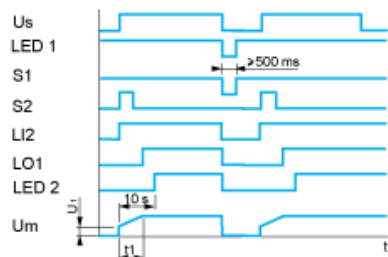

Us : Power supply voltage

LED Green LED

1 :

S1, Pushbuttons

S2 :

LI2 : Logic input

LO1 : Logic output

LED Yellow LED

2 :

Um : Motor voltage

t1 : Acceleration time can be controlled by a potentiometer

U1 : Starting time can be controlled by a potentiometer

## With Deceleration



Us : Power supply voltage

LED Green LED

1 :

S1, Pushbuttons

S2 :

LI1, Logic inputs

LI2 :

LO1 : Logic output

LED Yellow LED

2 :

Um : Motor voltage

t1 : Acceleration time can be controlled by a potentiometer