



# Supo Castor & Wheel Pte Ltd

No 39 Woodlands Close, Mega@Woodlands #03-23 Singapore 737856  
Tel: 65 6271 7200 Fax: 65 6482 7097  
Email: support@supocaster.com.sg  
Website: https://www.supocaster.com.sg/

# Ladder Trolleys

## LT Spring Loaded Ladder Trolley

- 2 in 1 Ladder Trolleys are designed with spring loaded steps to prevent accidental movement whilst in operation.
- It comes in two ready-made height versions for easy access for hard to reach shelf heights.

**Step module drops and brakes again the ground when operator starts to climb**



Model		LT3	LT5
Colour		Beige	Blue
Finishing		Epoxy Power Coating	
Weight	kg	47	54
Ladder Step		Epoxy Power Coating	
Dimension	a mm	1136	2040
	b mm	1022	1573
	c mm	730	1283
	d mm	715	486
	e mm	1070	1070
Overall Width	mm	555	
Wheel		05" Swivel Castor/Swivel Brake	
Loading	kg	Top 50/UDL, Bottom 150/UDL	
Capacity	kg	350	

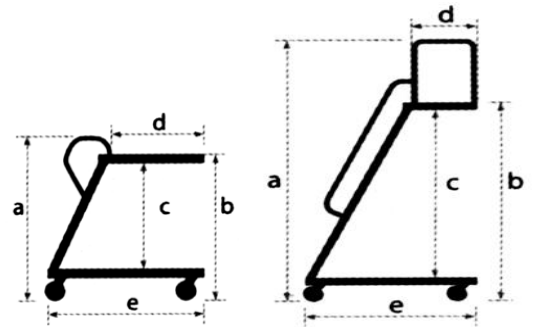

## FINISH WITH EPOXY POWDER COATING

- An epoxy coating or paint is a protective material made from epoxy-based resin.
- It provides outstanding resistance to corrosive chemicals, heat, and ultra-violet light.



**Ladder Trolley  
LT 5**

For safety purpose additional gas spring are designed to prevent contact with pinch points.



**Gas Spring**

5" Swivel with brake caster wheel suitable for indoor and outdoor operation.



**Front Wheel (2 locking Device)**