

# XAPA3100

Empty control station without hinges, Harmony XAP, XB2 SL, plastic, grey, undrilled, 151x241x87mm



## Main

Range of product	Harmony XAP
Product or component type	Empty control station without hinges
Device short name	XAPA
Product front plate size	151 x 241 mm
Usable depth	83 mm
Number of cut-out	Undrilled
Colour of base of enclosure	Grey
Colour of cover	Grey
Material	Glass reinforced polyester
Cable entry	Undrilled
Device mounting	Flush
IP degree of protection	IP65 conforming to IEC 60529 IP69 conforming to NF C 20-010 IP69K
Resistance to chemical agents	High resistant to acids High resistant to all solvents High resistant to bases High resistant to diesel High resistant to mineral salts High resistant to oils and greases High resistant to petrol High resistant to sea water

## Complementary

Net weight	0.86 kg
Flame retardance	M3 conforming to CSTB VO conforming to UL 94

## Environment

Protective treatment	TH TC
Ambient air temperature for storage	-40...70 °C
Ambient air temperature for operation	-40...70 °C
Overvoltage category	Class II conforming to IEC 60536 Class II conforming to NF C 20-030
Fire resistance	850 °C conforming to NF C 20-455 960 °C conforming to IEC 92

## Packing Units

Unit Type of Package 1	PCE
Number of Units in Package 1	1
Package 1 Height	13 cm
Package 1 Width	16.6 cm
Package 1 Length	24.5 cm
Package 1 Weight	1.032 kg
Unit Type of Package 2	S03

Number of Units in Package 2	4
Package 2 Height	30 cm
Package 2 Width	30 cm
Package 2 Length	40 cm
Package 2 Weight	4.616 kg
Unit Type of Package 3	P06
Number of Units in Package 3	32
Package 3 Height	77 cm
Package 3 Width	80 cm
Package 3 Length	60 cm
Package 3 Weight	45.38 kg

### Offer Sustainability

Sustainable offer status	Green Premium product
REACH Regulation	<a href="#">REACH Declaration</a>
REACH free of SVHC	Yes
EU RoHS Directive	Pro-active compliance (Product out of EU RoHS legal scope) <a href="#">EU RoHS Declaration</a>
Toxic heavy metal free	Yes
Mercury free	Yes
China RoHS Regulation	<a href="#">China RoHS Declaration</a>
RoHS exemption information	<a href="#">Yes</a>
Environmental Disclosure	<a href="#">Product Environmental Profile</a>
Circularity Profile	No need of specific recycling operations

### Contractual warranty

Warranty	18 months
----------	-----------

Dimensions and Fixing

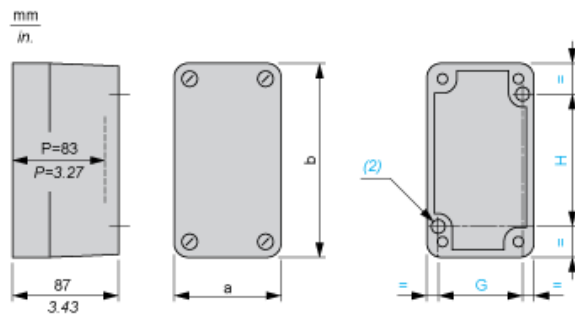

- (2) 2 x Ø 5.6 mm/4.94 in. holes, depth 12 mm/0.47 in.  
P Usable depth

a		b		G		H	
mm	in.	mm	in.	mm	in.	mm	in.
151	5.94	241	9.49	135	5.31	200	7.87