



Product Datasheet

Anti-Vandal Indicator

Pilot Lamp 12mm

ENGLISH

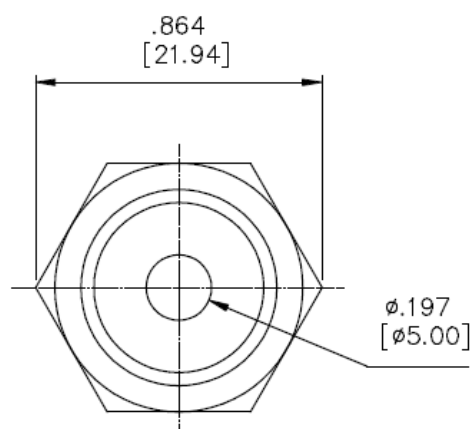
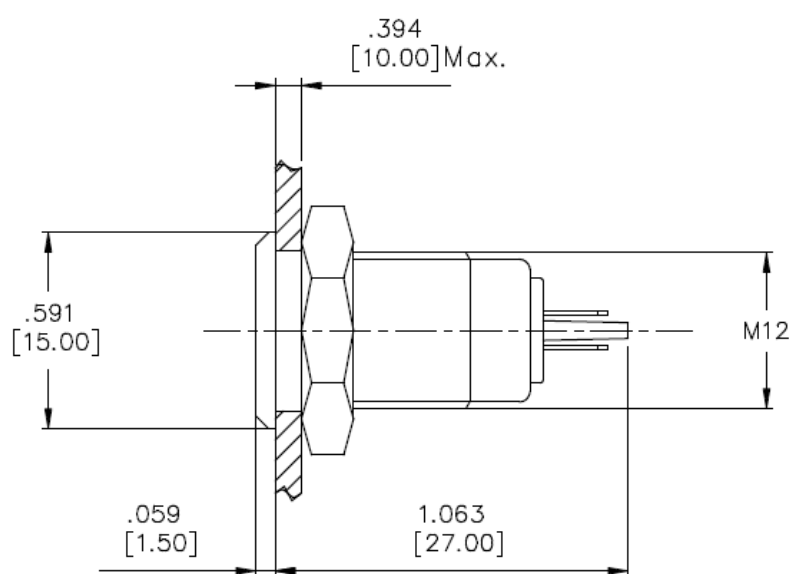



ENGLISH

Package Contain:

- 1 x Indicator
- 1 x Hex Nut
- 1 x Washer
- 1 x O-ring

Specification:

SWITCH TYPE:		8200582
MOUNTING SIZE:		M12
ELECTRICAL & MECHANICAL CHARACTERISTICS	CONTACT RATING:	MAX. 15mA @ 3~48VDC
	ELECTRICAL LIFE:	200,000 make-and-break cycles at 100mA 24VDC 10,000 make-and-break cycles at 2A 125VAC
	MECHANICAL LIFE:	Min. 1,000,000 cycles without load
	CONTACT RESISTANCE:	50m-ohms max. initial @ 2-4VDC, 100mA
	INSULATION RESISTANCE:	Apply 250VDC for 1min±5sec. After which measurement to be made between live parts and dead-metal parts shall result 100M-ohms min.
	DIELECTRICAL STRENGTH:	2,000VAC (50Hz-60Hz) RMS @ sea level shall result no damage to parts arcing or flashover
	OPERATING TEMPERATURE:	-20Celsius degree to +55Celsius degree
	TORQUE:	5~14Nm max. applied to nut
	IP PROTECTION CLASS:	Front panel protection to IP67
	IMPACT RESISTANCE:	IK10 striking energy 20 joules (EN 50102, IEC 62262:2002)
	SOLDERING HEAT RESISTANCE:	Max soldering temperature @ 260Celsius degree, immersion time 5+/-1sec, frequency of soldering process @ 2 times max.
	COLD TEST:	Stored at temperature -20(+/-3)Celsius degree for 48 hours, shall result no changes to switch's electrical performance
	HOT TEST:	Stored at temperature +55(+/-3)Celsius degree for 48 hours, shall result no changes to switch's electrical performance
HUMIDITY TEST:	Stored at temperature 40(+/-3)Celsius degree with relative humidity 90%~95% for 48 hours, shall result no changes to switch's electrical performance	
SALT SPRAY RESISTANCE:	Stored at temperature @ 35(+/-3)Celsius degree, and salt solution concentration of 5% with full air temperature @ 47(+/-3) Celsius degree and air pressure 1.0kg for 48 hours. The switch shall result no corrosion as well as no apparent changes to its functional performance. Per ASTM-B117 & JIS-Z371 STD.	



MATERIAL CHARACTERISTICS	LENS:	PC
	BUSHING:	Nickel plated brass
	BASE:	PBT
	LED:	Green, 15mA @ 24V, AC/DC Compatible
	O-RING:	Silicone
	HARDWARE:	Nut – nickel plated brass Washer - nickel plated steel
SOLDERING & CLEANING RECOMMENDATION	HAND SOLDERING:	Max. temperature @ 350Celsius degree (662F)with continuous soldering time @ 3sec. max. Recommend lead-free solder paste Sn96.5Ag3Cu0.5, soldering irons of 25-40 watts max. and solder of 0.030~0.040 dia.
	WAVE SOLDERING:	No-clean flux wave soldering is recommended so the switch does not require washing after soldering process. Noted, not to have flux migrate inside the switch through the top of the housing or actuator to prevent contamination. Max temperature @ 260Celsius degree (500F) for 10 sec.
	CLEANING PROCESS:	Noted, the switch is “not totally sealed” so it is important not to immerse/spray or clean unsealed areas of the switch during flux removal. Improper cleaning could cause switch deficiencies such as intermittence or open contact failures
PACKAGE	INTERNAL PACKAGING:	1pcs per PE bag
	RoHS IDENTIFICATIONS:	Bag is attached with a label marking “RoHS”